

ZECA

Z

TECHNICAL EXCELLENCE. SINCE 1929.

CABLE REEL FOR ELECTRIC CARS SERIES EV2WB

ART. EV2162 WB+

Length (m)
5

Cable type
3G2,5 + 1X0,5

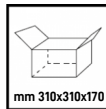
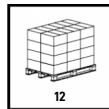

TECHNICAL DATA

Article	Cable length (m)	Cut length (m)	Cable type	Winder protection grade	Recharge type	Output plugs	Wi-fi	With wallbox	Input socket on wallbox side
EV2162 WB+	5	1,5	3G2,5 + 1X0,5	IP42	3,8 Kw (16 A @ 230V)	type 1	YES	YES	NO

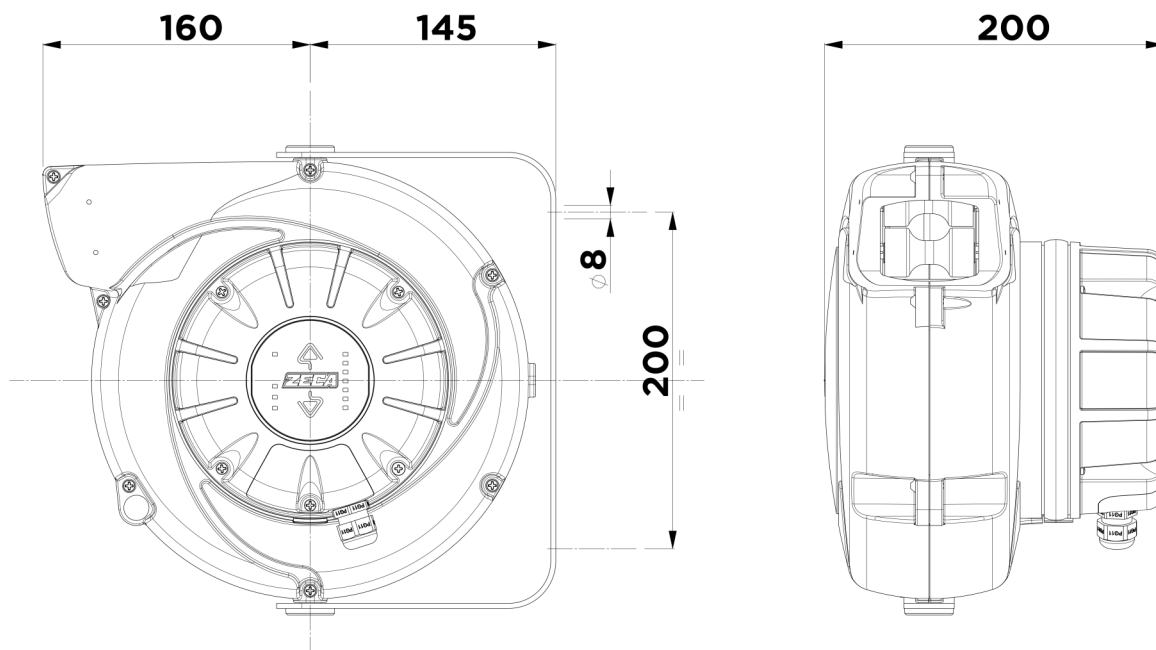
OVERALL DIMENSIONS**Technical features**

With EV ZECA cable reels with wallbox, it is possible to recharge electric vehicles with minimum effort, while keeping the garage tidy and protecting the cables from wear.

Available with Type 1 and Type 2 connectors

The Type 1 connector is the North American and Japanese standard, but it is very common on vehicles (it is not usually installed on board the charging stations). This connector can only be used for single-phase refills.

The Type 2 connector is the European standard for AC charging stations and is the most used connector on electric cars by European electric vehicle manufacturers. This connector can be used for both single-phase and three-phase recharges.

Wi-Fi available for models EV2161WB+ and EV2162WB+

ATTENTION: when installing the product, remember to connect the thermal protection according to one of the two diagrams found inside the package.