

GOODSON

Tools and Supplies for Engine Builders

2022

www.goodson.com • 1-800-533-8010

From The President's Desk

Unless you've been living under a rock, you know the past couple of years have been challenging for businesses. We could sit back and let those challenges frustrate us or wear us down, but that's not the Goodson way.

As we step into 2022, Goodson employee-owners are working hard to rise above the supply chain challenges we've seen. We're ordering larger quantities with greater frequency to keep our shelves stocked with the tools and supplies you need.

We will continue to provide the finest, friendliest customer service in the industry – NO MATTER WHAT. You can continue to count on Goodson for

- Same-Day Shipping
- Iron-Clad Satisfaction Guarantee
- Goodson Techxperts™ As Close As A Phone Call
- In-House Crankshaft & Camshaft Grinding Wheel Shaping & Sizing
- In-House Abrasive Belt Manufacturing
- Full Service ... FAST!



Roger Schumacher,
Goodson President



GOODSON Ironclad Guarantee

Goodson won't risk losing your business for any reason. If you're not 100% satisfied with your purchase, we'll fix it,

exchange it or credit your account for the purchase price. To send an item back, just include a note detailing the reason for the return and ship it back, freight pre-paid within 60 days. The only time we can't honor this guarantee is if a tool has been damaged through misuse or modification. All abrasives have a shelf life so we can only guarantee them for one year from the original purchase date.

Do You Have An Idea For The Next Great Product?

Many of the ideas for our most successful new products come directly from you, the guys in the shop. You work in this industry and have come up with pretty creative solutions to everyday problems. A great case in point is the Bucket Lifter Grinder you'll find a couple of pages over.



Richard Orlikowski,
Goodson Product Manager

Give me, Richard Orlikowski, a call to learn more about how you can have Goodson produce and market your new product idea. Just think, yours could be the next great idea Goodson brings to the market.

Supply Chain Shortages

As you are no doubt aware there are major supply chain shortages and rising prices affecting our industry at this time. We will do everything in our power to honor the prices printed in this catalog, but be aware we may need to update pricing as the market fluctuates.

Contact Us

Goodson offices are open from 8:00am to 5:00pm, Monday through Friday (Central time).

Phone: 1-800-533-8010 (US & Canada)
1-507-452-1830 (International)

Fax: 1-888-466-3909 (US & Canada)
1-507-452-2907 (International)

Please note that the Goodson offices will be closed in observance of the following 2022 holidays: Memorial Day (May 30), Independence Day (July 5), Labor Day (September 5), Thanksgiving (November 24 & 25), Christmas (December 23 & 26) and New Year's Eve (December 30).

We're always open on the web!

Web: www.goodson.com

Email: orderdesk@goodson.com



Watch for this symbol throughout the catalog

We know pictures often tell the story better than words so we are making videos for many of the products in the Goodson product line. The symbol above indicates that there is a video available for that product. Where space allows we are including a QR code that will take you directly to the video. All you need to do is point your smartphone camera at the code and the link will open.



Mach-B Grinding Wheel Shaping & Resizing

From routine grinding wheel shaping and sizing to emergency work, ***Mach-B Can Do That!***

Mach-B Grinding Wheel Shaping & Resizing specializes in:

- Custom Grinding Wheel Shaping
- Custom Grinding Wheel Sizing
- Reducing Outside Diameters
- Increasing Inside Diameters
- ANSI Compliant Speed Testing
- Static Balance Testing
- Standard and Custom Profiles
- Grinding Wheel Slotting



Turn to Mach-B and Goodson for Fast Turnaround. Visit www.mach-b.com for more information.

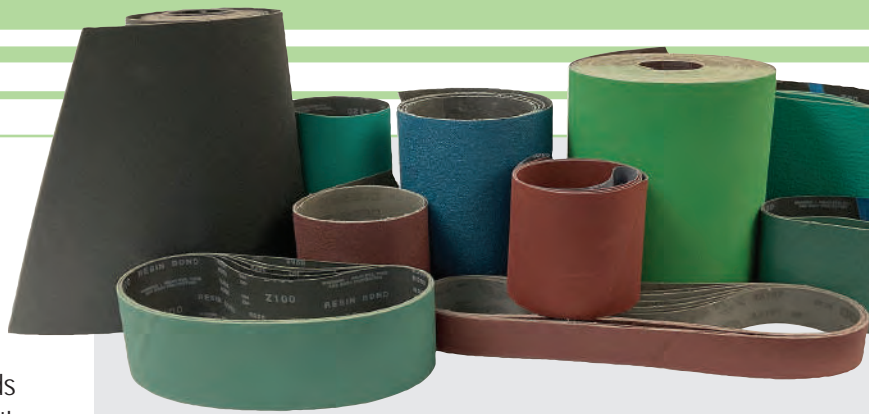

Custom Abrasive Belts

- Any Length (up to 520")
- Any Width (up to 15")*
- Aluminum-Oxide
- Ceramic-Alumina
- Silicon-Carbide
- Zirconia-Alumina
- 36 to 600 Grit*

Abrasive Industrial Supplies Has You Covered!

Abrasive Industrial Supplies (AIS) is a division of Goodson specializing in stock and custom grinding, sanding and polishing belts. We make belts in-house and can make whatever size belt you need.

*Grit & width availability varies by abrasive grain.

Choose from a variety of abrasives in several grits and backings for a wide range of applications.

You can order directly from AIS by calling **1-800-433-8010** or visiting the website; www.abrasiveindustrialsupplies.com OR talk to your Goodson customer service rep.

Now that's ONE STOP SHOPPING!



Abrasive Industrial Supplies
A Division of Goodson



A TYROLIT Company

RAPIDEX

A rapid-use index of product categories

Cylinder Head Rebuilding

Pilots.....	5-7
Valve Seat Work.....	8-26
Valve Refacing.....	27-31
Reamers.....	32-33
Valve Guide Resizing.....	34-36
Valve Guide Replacement.....	37-41
Valve Seal Work.....	42
Valve Spring Work.....	43-48
Cylinder Head Resurfacing.....	49-53
Crack Detection & Repair.....	54-57
Porting & Polishing.....	60-62

Cleaning, Assembly & Safety

Parts Storage & Organizers.....	63-65
Parts Baskets.....	65
Wire Wheels & Brushes.....	66-67
Cleaning.....	68-71
Last Blast Paint & Metal Markers.....	72
Assembly Lubes.....	73
Coolants & Lubricants.....	74-76

Index	77-84
Flex-Hones®.....	85

Short Block Rebuilding

Boring Bar Tooling & Supplies.....	86-87
Cylinder Honing.....	88-94
Rod Honing.....	93
Rod & Piston Work.....	95-98
Lifter Bore Tooling.....	101
Camshaft Work.....	102-103

Crankshaft/Flywheel Grinding

Crankshaft Grinding Wheels.....	104-105
Crankshaft Grinding & Polishing.....	106-111
Flywheel Grinding.....	112-115

Miscellaneous Tools

Diamond Dresser Tools.....	116-117
Miscellaneous.....	118

Brake Service Tooling

Brake Tips & Holders.....	119-120
Brake Lathe Silencers.....	121
Brake Lathe Replacement Parts.....	122-124

Measuring Tools

Straight Edges.....	125
Dial Bore Gauges.....	127-128
Calipers & Dial Indicators.....	129
Micrometers.....	130

V-Twin Hard Parts

Valve Springs.....	132-135
Seats & Seat Inserts.....	135
Valve Guides.....	136
Replacement Valves.....	137

© Copyright 2022, Goodson Mfg. Co., Inc. All copy and illustrations are copyrighted. Absolutely no mechanical or electronic reproduction or use of any part is allowed without our prior written permission. Goodson reserves the right to correct printing errors. Prices are subject to change without notice.

Policies

See page 84 for more information about these policies.

Pricing:

Prices are subject to change without notice. There is no minimum order. Orders are billed at the prices in effect at the time of shipping. Discounts are not available on Sunnen® products.

Shipping:

Goodson typically ships orders the same day they are received. Orders received after 2:00pm (central), on weekends or holidays are shipped the next business day. If your order is lost in shipping, Goodson works with the shipper to provide tracking service. Please inspect all shipments upon receipt and report damage or errors within 48 hours.

Freight:

For orders shipped ground within the USA, you may deduct the freight charges on any **JOBBER** net invoice of \$800 or more if you pay within 30 days of the invoice date. Glass Beads, Steel Shot, Tumbler Media, Machines, Equipment, Bulk Liquids, Cleaning Detergents and Crankwheels are not included. Hazardous Materials, Dangerous Goods & Dimensional Shipping fees may apply on some items.

Terms:

- 1) A 1% discount is given on merchandise if payment is made within 15 days from **invoice** date. This discount applies only to the merchandise amount (not the total amount) on the **invoice** (not a statement). The discount amount is shown in the lower left hand corner of the invoice. This discount does not apply to statement payments and does not apply to credit card orders.
- 2) Balances not paid in full within 30 days are subject to a finance charge of 1.5% per month (18% per year).

Credit & Debit Card Orders:

Goodson accepts MasterCard, Visa, American Express, Discover Card and PayPal. For your security, credit card numbers are **NOT** kept on file. Credit Card and PayPal orders do not qualify for the 1% quick-pay discount.

Check Acceptance:

In the unlikely event that your check is returned for insufficient or held funds, we will debit your checking account electronically for the face amount of the check plus the service fee allowed by your state's law. This allows us to resolve the problem without turning you over to a collection agency and harming your credit rating. The transaction will appear on your bank statement and no one will have to contact you about payment.

Returns:

You may return any item, except special orders, within 60 days. We will do our best to correct any problems or to send a replacement. If an item was damaged through mis-use or modification, Goodson will not accept it as a return. Credits will only be issued after it is determined that the part is resellable or it is deemed defective.

Some Hazardous Materials are Non-returnable due to shipping regulations. See our policies on the last page of the index for more details or call us toll-free at 1-800-533-8010.

ABRASIVES WARRANTY: Abrasives have a shelf life, therefore, all abrasives are warranted against manufacturing defects for 1 year from the date of original purchase.

RESETTING/RESHARPENING SERVICE: Premium Diamonds can be reset and many of our cutting tools can be resharpened. Send your resets and sharps to GOODSON Tools & Supplies, ATTN: Resharps, 156 Galewski Dr. Winona, MN 55987. Be sure to include your customer number.



Introducing the NEW SABER TOOTH SERIES Valve Seat Cutter Blade

SABER TOOTH SERIES CUTTER BLADES

The toughest, longest lasting valve seat cutter blade on the market!

- Manufactured from a special alloy designed to make cutting hardened or multi-alloy valve seat materials faster and easier
- Provide up to 30% longer life • 0° knife edge
- Part numbers are unchanged for easy reordering see pages 10 to 13 for profiles



Enlarged to show detail

Over 100 Profiles



Visit Goodson.com for a side-by-side demonstration video showing how these cutters stack up against the original carbide cutter blades. Scan the code at right with the camera on your smart phone or other smart device for quick access.



Back and Better Than Ever!

Goodson exclusive

7075 Aircraft Aluminum Frame

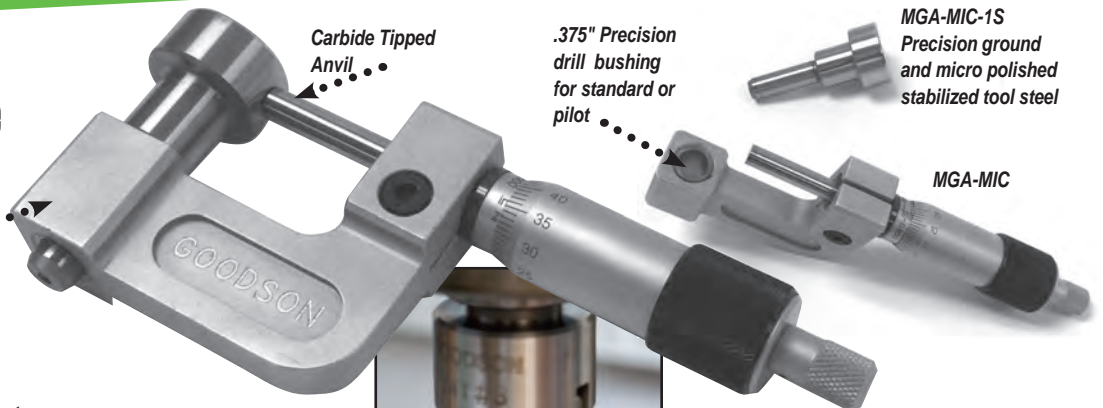

Carbide Tipped Anvil

.375" Precision drill bushing for standard or pilot

MGA-MIC-1S Precision ground and micro polished stabilized tool steel

MGA-MIC

3-D Fast Cut Setting Micrometer

- Direct reading micrometer accurate to .001"
- Uses tapered .375" bottom pilot to match your ball head (sold separately)
- Use to set cutting diameter of 90° carbide cutters when modifying counterbores
- Use the optional calibration standard to ensure your micrometer is reading correctly

Description	Cutting Range	Jobber	Order No.
Standard Micrometer	0.800" - 2.800"	\$449.99	MGA-MIC
Calibration Standard		74.99	MGA-MIC-1S



Watch the Tech Lab Tuesday Video about Counterbore Cutting with the 3-D Fast Cut™ System to see how to set up your cutter using the MGA-MIC Setting Micrometer. Scan the code at right with the camera on your smart phone or other smart device for quickly access the video.



CYLINDER HEAD REBUILDING
CLEANING, ASSEMBLY & SAFETY
SHORT BLOCK REBUILDING
FLYWHEEL GRINDING
CRANKSHAFT/
LANEWAYS
SUPPLIES
BRAKE SERVICE
TOOLING
MEASURING
TOOLS
V-TWIN & METRIC
HARD PARTS



CSS ULTRA Grinding Wheels Feature the Latest & Greatest Bond Technology for High Performance Grinding

- New wheel formulation from Tyrolit combines high-quality components and innovative bonding technology
- Minimizes heat generation and the forces imposed on the workpiece
- Grit mixture of white and sintered aluminum oxide

LONG LIFETIME

CSS ULTRA provides long lifetime and good profile retention. Due to the high strength bond system the abrasive grain can withstand much greater loads during use without premature breakdown.

COOL GRINDING

No burning. The high strength bond system allows for less bond content which decreases friction for a cooler grind.

HIGH PRODUCTIVITY

Stock removal rates with CSS ULTRA can be increased without sacrificing quality.



Application Example	Components
Automotive Industry: Crankshaft - grinding bearing journal CSS ULTRA 1KN 1065x40x305 CS33A54IKK6VB1 50 Increase in lifetime of 50%	crankshaft camshaft gear shaft CV joint



CSS ULTRA 8" Arbor Crankshaft Grinding Wheels

Face Width	26" Diameter	28" Diameter
3/4" - 1"	\$579.99	\$634.99
1 1/64" - 1 1/4"	634.99	709.99
1 17/64" - 1 1/2"	659.99	744.99
1 33/64" - 1 3/4"	744.99	834.99
1 49/64" - 2"	754.99	849.99
2 1/64" - 2 1/4"	859.99	974.99

Need a different size? Call Goodson today.

3D-CLIP



Fits standard 1" ball head

3-D Fast Cut Sunnen Drive Adaptor

- Designed to accommodate the 3-D Lift Clip for greater tooling control
- Fits standard 1" ball-heads
- Ideal when machining spring pads, valve guides, etc.

Description	Jobber	Order No.
Sunnen Drive Adaptor	\$419.99	3D-SUN
3-D Lift Clip	24.99	3D-CLIP

Back by Popular Demand

Pin Press Reducing Ring

- Goodson is now the authorized manufacturer of the Sunnen® Pin Press Reducing Ring
- Same specs and design
- Use with the Goodson Rod Support (page 95)
- Order No. **B-162** Jobber \$99.99

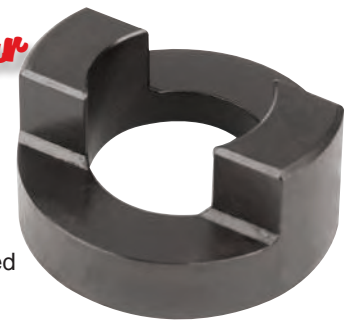

Replacement V-Belts for Sunnen® VGS-20 Seat & Guide Machine

- Poly V-Belts
- Milled construction
- Shippable worldwide

Application	Length	Replaces OE#	Jobber	Order No.
Drive	22"	PDB-310A/ST-467X	\$30.99	VGS-20-22
Countershaft	30"	PDB-309A/ST-467W	41.99	VGS-20-30

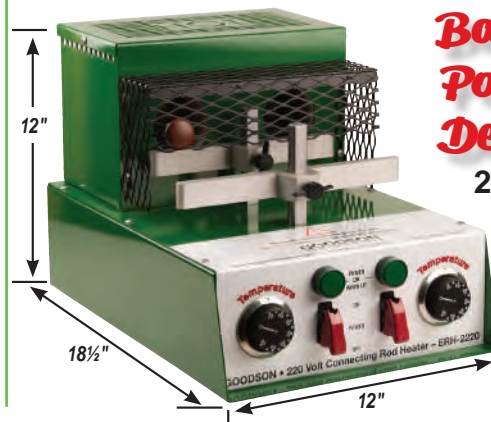

Back by Popular Demand

220V Electric Rod Heater
See page 97 for details

Solid Tapered Pilots

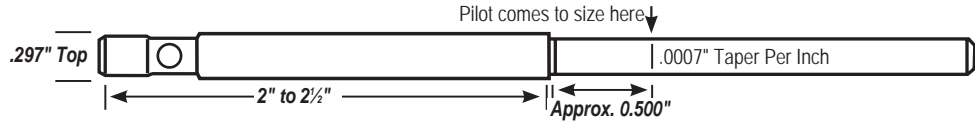

.297" Solid-Tapered High Speed Steel Pilots

Inch	mm	OAL	Order No.	Inch	mm	OAL	Order No.	Inch	mm	OAL	Order No.	Inch	mm	OAL	Order No.
.1496"	3.80	3.375"	P-1149N	.1779"	4.52	4.50"	P-1178N	.2362"	6.00	4.50"	P-1236N	.2500"	6.35	4.50"	P-1250N
.1574"	4.00	4.50"	P-1158N	.1968"	5.00	4.50"	P-1197N	.2370"	6.02	4.50"	P-1237N	.2510"	6.37	4.50"	P-1251N
.1582"	4.02	4.50"	P-1159N	.1976"	5.02	4.50"	P-1198N	.2381"	6.05	4.50"	P-1238N	.2598"	6.60	4.50"	P-1260N
.1771"	4.50	4.50"	P-1177N	.2165"	5.50	4.50"	P-1216N	.2490"	6.32	4.50"	P-1249N	.2810"	7.14	4.50"	P-1281N
Jobber			\$26.99	Jobber			\$26.99	Jobber			\$26.99	Jobber			\$26.99

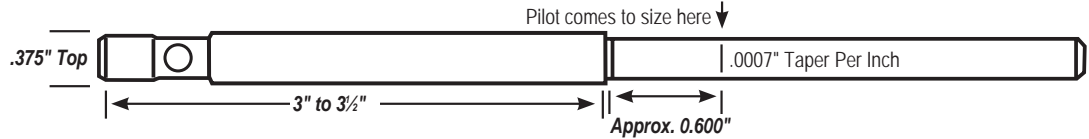

.375" Solid-Tapered High Speed Steel Pilots

Inch	mm	OAL	Order No.	Inch	mm	OAL	Order No.	Inch	mm	OAL	Order No.	Inch	mm	OAL	Order No.
.1771"	4.50	6.00"	P-5177N	.2490"	6.32	6.00"	P-5249N	.2952"	7.50	6.00"	P-5295N	.3417"	8.67	6.50"	P-5341N
.1960"	4.98	6.00"	P-5196N	.2500"	6.35	6.00"	P-5250N	.3095"	7.86	6.00"	P-5309N	.3427"	8.70	6.50"	P-5342N
.1968"	5.00	6.00"	P-5197N	.2559"	6.50	6.00"	P-5256N	.3105"	7.88	6.00"	P-5310N	.3437"	8.72	6.50"	P-5343N
.1976"	5.02	6.00"	P-5198N	.2566"	6.52	6.00"	P-5257N	.3115"	7.91	6.00"	P-5311N	.3447"	8.75	6.50"	P-5344N
.2165"	5.50	6.00"	P-5216N	.2598"	6.60	6.00"	P-5260N	.3125"	7.93	6.00"	P-5312N	.3457"	8.78	6.50"	P-5345N
.2173"	5.52	6.00"	P-5217N	.2748"	6.98	6.00"	P-5274N	.3135"	7.96	6.00"	P-5313N	.3543"	9.00	6.50"	P-5354N
.2185"	5.55	6.00"	P-5218N	.2756"	7.00	6.00"	P-5275N	.3145"	7.98	6.00"	P-5314N	.3551"	9.02	6.50"	P-5355N
.2354"	5.98	6.00"	P-5235N	.2763"	7.02	6.00"	P-5277N	.3149"	8.00	6.00"	P-5315N	.3587"	9.11	6.50"	P-5358N
.2362"	6.00	6.00"	P-5236N	.2775"	7.05	6.00"	P-5278N	.3165"	8.03	6.00"	P-5316N	.3730"	9.47	7.00"	P-5373N
.2370"	6.02	6.00"	P-5237N	.2792"	7.09	6.00"	P-5279N	.3407"	8.65	6.50"	P-5340N	.3740"	9.49	7.00"	P-5374N
Jobber			\$35.99	Jobber			\$35.99	Jobber			\$35.99	Jobber			\$35.99

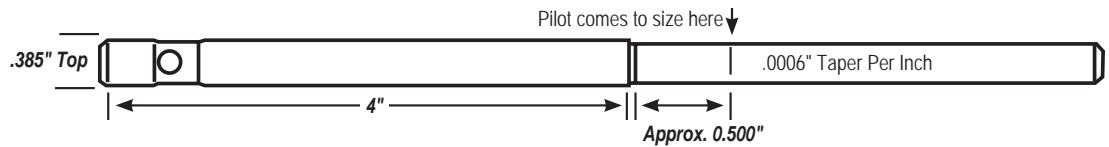

.385" Solid-Tapered High Speed Steel Pilots

Inch	mm	OAL	Order No.	Inch	mm	OAL	Order No.	Inch	mm	OAL	Order No.	Inch	mm	OAL	Order No.
.2165"	5.50	7.50"	P-5216S	.2598"	6.60	7.50"	P-5260S	.3125"	7.94	7.50"	P-5312S	.3420"	8.68	7.50"	P-5342S
.2173"	5.52	7.50"	P-5217S	.2744"	6.97	7.50"	P-5274S	.3130"	7.95	7.50"	P-5313S	.3430"	8.71	7.50"	P-5343S
.2350"	5.97	7.50"	P-5235S	.2755"	7.00	7.50"	P-5275S	.3141"	7.98	7.50"	P-5314S	.3440"	8.73	7.50"	P-5344S
.2362"	6.00	7.50"	P-5236S	.2763"	7.02	7.50"	P-5276S	.3149"	8.00	7.50"	P-5315S	.3450"	8.76	7.50"	P-5345S
.2370"	6.02	7.50"	P-5237S	.2771"	7.04	7.50"	P-5277S	.3161"	8.03	7.50"	P-5316S	.3543"	9.00	7.50"	P-5354S
.2381"	6.05	7.50"	P-5238S	.2779"	7.06	7.50"	P-5278S	.3170"	8.05	7.50"	P-5317S	.3550"	9.02	7.50"	P-5355S
.2500"	6.35	7.50"	P-5250S	.3100"	7.87	7.50"	P-5310S	.3410"	8.66	7.50"	P-5341S	.3560"	9.04	7.50"	P-5356S
Jobber			\$49.99	Jobber			\$49.99	Jobber			\$49.99	Jobber			\$49.99

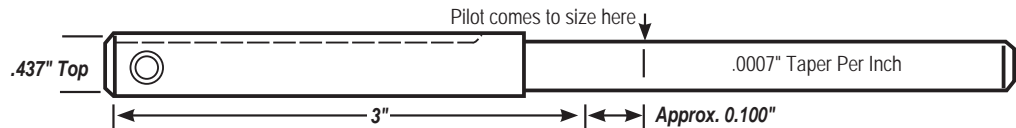

.437" Solid-Tapered High Speed Steel Pilots

Inch	mm	OAL	Order No.	Inch	mm	OAL	Order No.	Inch	mm	OAL	Order No.	Inch	mm	OAL	Order No.
.2165"	5.50	6.75"	P-5216K	.2381"	6.05	6.75"	P-5238K	.3115"	7.90	6.75"	P-5311K	.3150"	8.00	6.75"	P-5315K
.2185"	5.55	6.75"	P-5218K	.2755"	7.00	6.75"	P-5275K	.3125"	7.94	6.75"	P-5312K	.3157"	8.02	6.75"	P-5316K
.2362"	6.00	6.75"	P-5236K	.2763"	7.02	6.75"	P-5276K	.3135"	7.96	6.75"	P-5313K	.3169"	8.05	6.75"	P-5317K
.2370"	6.02	6.75"	P-5237K	.2775"	7.05	6.75"	P-5277K	.3145"	7.98	6.75"	P-5314K	.3427"	8.70	6.75"	P-5342K
Jobber			\$59.99	Jobber			\$59.99	Jobber			\$59.99	Jobber			\$59.99

CYLINDER HEAD
REBUILDING
CLEANING,
ASSEMBLY & SAFETY
SHORT BLOCK
REBUILDING
FLYWHEEL, GRINDING
CRANKSHAFT/
MISCELLANEOUS
TOOLS & SUPPLIES
BRAKE SERVICE
TOOLING
MEASURING
TOOLS
V-TWIN & METRIC
HARD PARTS

CYLINDER HEAD REBUILDING
CLEANING, ASSEMBLY & SAFETY
SHOCK BLOCK REBUILDING
CRANKSHAFT/ FLYWHEEL GRINDING
MISCELLANEOUS TOOLS & SUPPLIES
BRAKE SERVICE TOOLING
MEASURING TOOLS
V-TWIN & METRIC HARD PARTS

Every Expanding Pilot Comes Complete With A Collet & Expander

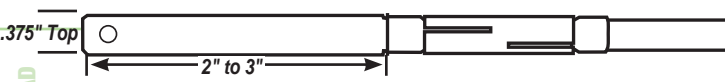
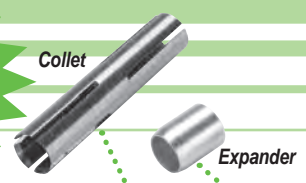

.375" Top Expanding Pilots

• Includes Collet & Expander • Expand up to .020" (.51mm)

Size	mm	Range	Pilot	Collet	Expander
.216"	5.50	.213"-.233"	P-5.5MMNX	P-216-COLLET	P-1216-EXP
.236"	6.00	.233"-.253"	P-6MMNX	P-6MM-COLLET	P-1236-EXP
.250"	6.35	.247"-.267"	————	P-250-COLLET	P-1250-EXP
.256"	6.50	.253"-.273"	P-6.5MMNX	P-65MM-COLLET	P-6.5MM-EXP
.275"	7.00	.272"-.292"	P-7MMNX	P-7MM-COLLET	P-7MM-EXP
.312"	7.92	.309"-.329"	P-312NX	P-312-COLLET	P-343-EXP
.335"	8.50	.330"-.350"	P-8.5MMNX	P-343-COLLET	P-343-EXP
.343"	8.70	.340"-.360"	P-343NX	P-343-COLLET	P-343-EXP
.375"	9.50	.372"-.392"	P-375NX	P-375-COLLET	P-375-EXP
.393"	10.00	.390"-.410"	P-10MMNX	P-10MM-COLLET	P-10MM-EXP
.437"	11.00	.430"-.450"	————	P-11MM-COLLET	P-11MM-EXP
.472"	12.00	.469"-.489"	————	P-12MM-COLLET	P-12MM-EXP
Jobber			\$51.99	\$18.99	\$10.99



.375" Extended Length Expanding Pilots

• Includes Collet & Expander • Expand up to .020" (.51mm)
• High Speed Steel

Size	mm	Range	Pilot	Collet	Expander
.3120"	7.92	.309"-.329"	P-312NXL	P-312L-COL	P-343-EXP
.3430"	8.71	.340"-.360"	P-343NXL	P-343L-COL	P-343-EXP
.3750"	9.52	.372"-.392"	P-375NXL	P-375L-COL	P-375-EXP
Jobber			\$56.99	\$18.99	\$10.99

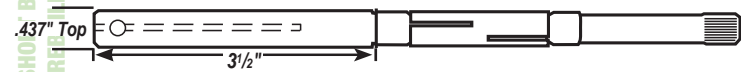

.437" Top Expanding Pilots

• Includes Collet & Expander • Expand up to .020" (.51mm)

Size	mm	Range	Pilot	Collet	Expander
.236"	6.00	.233"-.253"	P-6MMKX	P-6MM-COLLET	P-1236-EXP
.275"	7.00	.272"-.292"	P-7MMKX	P-7MM-COLLET	P-7MM-EXP
.312"	7.92	.309"-.329"	P-312KX	P-312-COLLET	P-343-EXP
.343"	8.70	.340"-.360"	P-343KX	P-343-COLLET	P-343-EXP
.375"	9.50	.372"-.392"	P-375KX	P-375-COLLET	P-375-EXP
.453"	11.50	.450"-.470"	P-453KX	P-11.5MM-COLLET	P-11MM-EXP
Jobber			\$64.99	\$18.99	\$10.99



.385" Top Expanding Pilots

• Includes Collet & Expander • Expand up to .020" (.51mm)

Size	mm	Range	Pilot	Collet	Expander
.236"	6.00	.233"-.253"	P-6MMSX	P-6MM-COLLET	P-1236-EXP
.250"	6.35	.247"-.267"	————	P-250-COLLET	P-1250-EXP
.256"	6.50	.253"-.273"	————	P-65MM-COLLET	P-6.5MM-EXP
.275"	7.00	.272"-.292"	P-7MMSX	P-7MM-COLLET	P-7MM-EXP
.281"	7.10	.278"-.298"	————	P-281-COLLET	P-281-EXP
.295"	7.50	.290"-.310"	————	P-281-COLLET	P-281-EXP
.312"	7.92	.309"-.329"	P-312SX	P-312-COLLET	P-343-EXP
.343"	8.70	.340"-.360"	P-343SX	P-343-COLLET	P-343-EXP
.375"	9.50	.372"-.392"	P-375SX	P-375-COLLET	P-375-EXP
.393"	10.00	.390"-.410"	P-10MMSX	P-10MM-COLLET	P-10MM-EXP
.406"	10.30	.403"-.423"	P-406SX	P-10MM-COLLET	P-10MM-EXP
.437"	11.00	.430"-.450"	P-11MMSX	P-11MM-COLLET	P-11MM-EXP
.453"	11.50	.450"-.470"	P-453SX	P-11.5MM-COLLET	P-11MM-EXP
.472"	12.00	.469"-.489"	P-12MMSX	P-12MM-COLLET	P-12MM-EXP
.500"	12.70	.497"-.517"	P-500SX	P-12MM-COLLET	P-12MM-EXP
Jobber			\$93.49	\$18.99	\$10.99



Valve Seat Wheel Dresser Pilots for Universal & Heavy Duty Wheel Dressers

• All pilots have a .625" bottom

Dresser Pilots (select based on stone holder type)			
Fits Stone Holder Type	OAL	Jobber	Order No.
A .437" Hex Stone Holder	5 7/8"	\$159.99	031-1102-89
B .437" Hex or Flex Stone Holder	7"	159.99	031-0202-80
C .385" Top Stone Holder	6"	159.99	031-0202-55
D .375" Top Stone Holder	6"	159.99	031-0202-47

Setting your expanding pilot

tech tips from the techxperts™

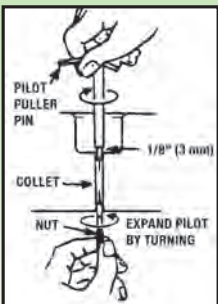

- 1 Select an expanding pilot that is the same diameter as the valve guide ID.
- 2 Insert the pilot into the valve guide making sure that the expanding section of the pilot (collet) is completely within the valve guide. The pilot will not center properly and may be damaged if the collet extends outside of the valve guide.
- 3 Pilot shoulder should be about 1/8" above the valve guide.
- 4 Hold the pilot while turning the nut at the opposite end. This will expand the collet and secure the pilot into position.

NOTE: DO NOT use Expanding Pilots with multi-angle valve seat cutting systems (ie: 3-D Fast Cut)

Carbide & Extra-Long Pilots



.236" Top Tapered Carbide Pilots

- Less deflection under stress • Due to the brittle nature of carbide we can only warranty carbide pilots for size

Inch	mm	Order No.	Inch	mm	Order No.	Inch	mm	Order No.
.1559"	3.96	PCT-1560M	.1968"	5.00	PCT-1970M	.2570"	6.53	PCT-2570M
.1566"	3.98	PCT-1570M	.1980"	5.03	PCT-1980M	.2578"	6.55	PCT-2580M
.1575"	4.00	PCT-1575M	.2161"	5.49	PCT-2160M	.2598"	6.60	PCT-2600M
.1578"	4.01	PCT-1580M	.2170"	5.52	PCT-2170M	.2759"	7.01	PCT-2760M
.1759"	4.47	PCT-1760M	.2181"	5.54	PCT-2180M	.2763"	7.02	PCT-2765M
.1771"	4.50	PCT-1770M	.2358"	5.99	PCT-2360M	.2771"	7.04	PCT-2770M
.1779"	4.52	PCT-1780M	.2560"	6.50	PCT-2560M			
Jobber		\$229.99	Jobber		\$229.99			

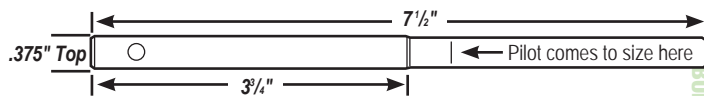

.375" Top Tapered Carbide Pilots

- Less deflection under stress • Due to the brittle nature of carbide we can only warranty carbide pilots for size

Inch	mm	Order No.	Inch	mm	Order No.	Inch	mm	Order No.
.1771"	4.50	PCT-1770	.2370"	6.02	PCT-2370	.3150"	8.00	PCT-3150
.1968"	5.00	PCT-1970	.2756"	7.00	PCT-2756	.3422"	8.70	PCT-3420
.2165"	5.50	PCT-2165	.2759"	7.01	PCT-2760	.3433"	8.72	PCT-3430
.2173"	5.52	PCT-2170	.2763"	7.02	PCT-2765	.3440"	8.73	PCT-3440
.2355"	5.98	PCT-2355	.2771"	7.04	PCT-2770	.3740"	9.50	PCT-3740
.2362"	6.00	PCT-2362	.3122"	7.93	PCT-3120	Jobber		\$229.99
Jobber		\$229.99	Jobber		\$229.99			

tech tips

from the techxperts™

We get asked from time to time why Goodson carries so many sizes and styles of pilots.

Most of us probably think of that in terms of Top and Bottom Size, but there's another dimension that's becoming more important every day. The pilot's top length.

You've probably worked on (or at least seen) heads with deeply set valves. This is especially common in diesel applications. Some of them are set so deeply that a standard pilot just won't cut it. You need a pilot that extends above the deck while still being fully seated in the guide in order to perform top quality seat work.

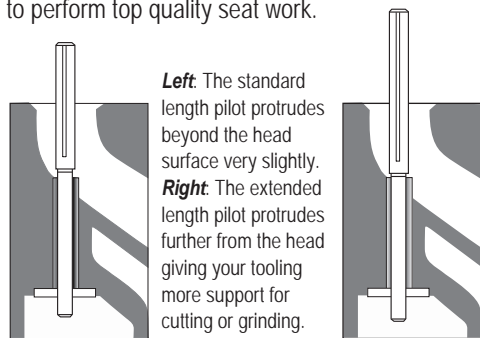

Left: The standard length pilot protrudes beyond the head surface very slightly.
Right: The extended length pilot protrudes further from the head giving your tooling more support for cutting or grinding.

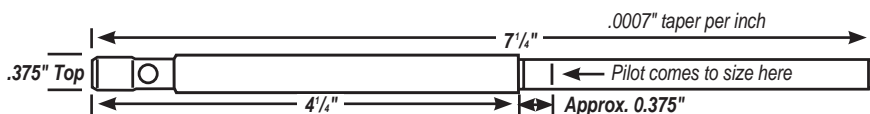

Extended Length (7 1/4") .375" Top Solid-Tapered High Speed Steel Pilots

Inch	mm	OAL	Order No.	Inch	mm	OAL	Order No.	Inch	mm	OAL	Order No.
.2598"	6.60	7.25"	P-5260NL	.3145"	7.98	7.25"	P-5314NL	.3437"	8.73	7.75"	P-5343NL
.2606"	6.62	7.25"	P-5261NL	.3150"	8.00	7.25"	P-5315NL	.3447"	8.75	7.75"	P-5344NL
.2755"	7.00	7.25"	P-5275NL	.3417"	8.68	7.75"	P-5341NL	.3457"	8.78	7.75"	P-5345NL
.2756"	7.01	7.25"	P-5276NL	.3427"	8.70	7.75"	P-5342NL	.3740"	9.50	7.75"	P-5374NL
Jobber			\$59.99	Jobber			\$59.99	.3750"	9.52	7.75"	P-5375NL
								Jobber			\$59.99

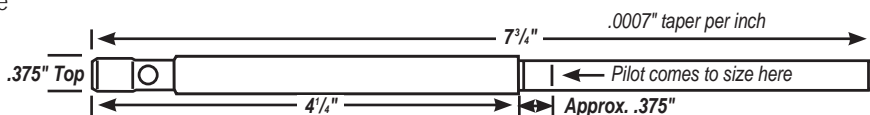

.375" Top Solid-Tapered Extra-Long (7 3/4") High Speed Steel Pilots

- Sized for diesel, aviation and other applications requiring longer pilots

Inch	mm	OAL	Order No.	Inch	mm	OAL	Order No.	Inch	mm	OAL	Order No.
.343"	8.72	7.75"	AP-5343	.406"	10.31	7.75"	AP-5406	.439"	11.15	7.75"	AP-5439
.344"	8.75	7.75"	AP-5344	.407"	10.34	7.75"	AP-5407	.498"	12.12	7.75"	AP-5498
.345"	8.78	7.75"	AP-5345	.408"	10.36	7.75"	AP-5408	.499"	12.67	7.75"	AP-5499
.375"	9.52	7.75"	AP-5375	.436"	11.07	7.75"	AP-5436	.500"	12.70	7.75"	AP-5500
.376"	9.55	7.75"	AP-5376	.437"	11.10	7.75"	AP-5437	.501"	12.73	7.75"	AP-5501
.377"	9.57	7.75"	AP-5377	.438"	11.12	7.75"	AP-5438	.502"	12.75	7.75"	AP-5502
Jobber			\$92.99	Jobber			\$92.99	Jobber			\$92.99

Sioux-Style Dresser Pilots & Bushings

- Replacement parts for the popular 1716 Seat Wheel Dresser no longer available from Sioux™
- .375" top pilot features a groove to fit Black & Decker holders • .600" bottom size

Description	Jobber	Order No.
.385" Top Pilot, .600" Bottom Size	\$85.99	1718A
.375" Top Pilot, .600" Bottom Size	84.99	1718-BD
Dressing Stand Bushings (2) for .375" & .385" Pilots	11.99	SK-9-10
Dressing Stand Bushings (2) for .572" Pilots	11.99	SK-11-12

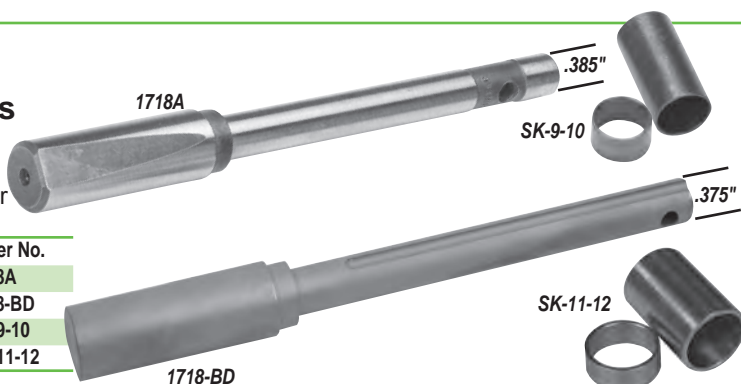

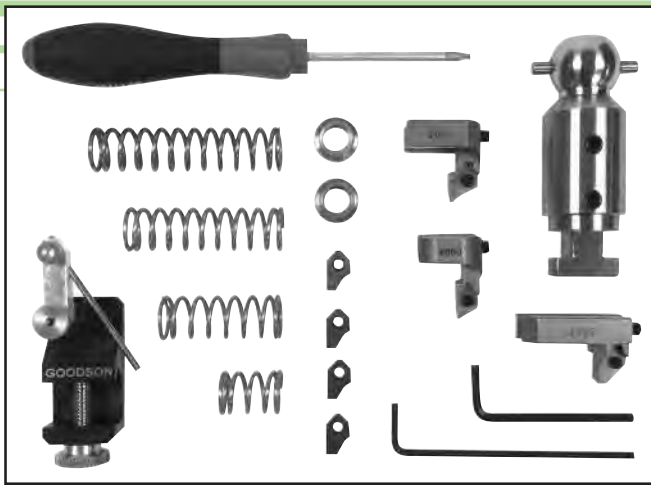

3-D Fast Cut™ Starter Kits

- Can be used with your existing pilots
- Ball heads are available to fit most common seat grinder pilots
- Choose from over 100 3-angle blade profiles on pages 10-13
- Fully compatible with most popular 3-angle cutting systems including Kwik-Way, Peterson, Rottler, Serdi, Sunnen, T&S, Winona Van Norman, Newen, etc.
- Use between 50 and 100 RPM • Goodson recommends starting at 60 RPM

Description	Fits Pilot	Jobber	Order No.	Includes
Complete Starter Kits	.375" / 9.53mm	\$1189.99	3D-375-KIT	
(see page 5 for pilots)	.385" / 9.78mm	1189.99	3D-385-KIT	
Ball Head Standard	.375" / 9.53mm	269.99	3D-BH375	x
3.346" long	.385" / 9.78mm	269.99	3D-BH385	x
	.375" / 9.53mm	369.99	3D-BHSUN-375	x
Ball Head Extended	.375" / 9.53mm	299.99	3D-BH375L	
Length 3.80" long				
Ball Head Wide Body	.375" / 9.53mm	439.99	3D-BH375W	
4.0625" long				
Serdi-Style Tool Bodies	Use with Serdi-style pilots			
4" long	Standard .375" / 9.53mm	\$379.99	SER-5100	
	Large Body .375" / 9.53mm	479.99	SER-5300	
Tip Holders	.709" - 1.181" / 18-30mm Range	209.99	3D-2000	x x
	1.02" - 1.653" / 26-42mm Range	209.99	3D-2001	x x
	1.575" - 2.362" / 40-60mm Range	209.99	3D-2002	x x
Tip Holders-Wide Body	1.575" - 2.362" / 40-60mm Range	289.99	3D-2003	
	2.385" - 3.150" / 58-80mm Range	289.99	3D-2004	
Cutters	45°/1.0mm	44.99	FT-45039V1	x x
	45°/1.3mm	44.99	FT-45051V1	x x
more on	45°/1.5mm	44.99	FT-45059V1	x x
pages 10-13	45°/1.9mm	44.99	FT-45075V1	x x
Tool Setting Fixture - All Steel Construction		159.99	3D-TSFA	x x
Cutter Blade Mounting Screw		5.99	FT-SCREW	x x
Blade Wrench		12.49	FT-WRENCH	x x
Automotive Bounce Spring Set (4 Pc.)		26.99	3D-SS4	x x
Bushing Set (1 pair)	.375"	9.99	3D-DB7	x
	.385"	9.99	3D-DB6	x
Ball Head	#3 Morse Taper Driver	419.99	3D-CM3	
	Bridgeport & DCM Driver	359.99	3D-3/4SS	
3-D Fast Cut™ Accessories				
Lift Clip for Enhanced Control, especially on Spring Pad Cutters (pg. 14)		\$24.99	3D-CLIP	
Replacement 3.0mm Allen Key		1.99	3D-3.0	x x
Replacement 2.5mm Allen Key		1.99	3D-2.5	x x
Replacement Screws for NWN Ball Head Base (5 Pack) - metric		2.19	MGA-4X5MM	
Replacement Base Screw for Standard Ball Heads M5x6MM		1.99	3D-56	
Replacement Base Screw for Wide Body Ball Heads M6x6MM		1.99	3D-66	
Replacement Side Screw for Standard Ball Heads M6x8MM, Brass Tip		4.99	3D-68	
Replacement Side Screw for Wide Body Ball Heads M6x16MM, Brass Tip		4.99	3D-615	
Adjusting Screw for Tip Holder #3D-2000, OAL: .395" /10mm		7.49	3D-2000-S	
Adjusting Screw for Tip Holder #3D-2001, OAL: .475" /12mm		7.49	3D-2001-S	
Adjusting Screw for Tip Holder #3D-2002, OAL: .625" /15.9mm		7.49	3D-2002-S	

See page 9 for Valve Seat Removal Tooling for the 3-D Fast Cut™ System

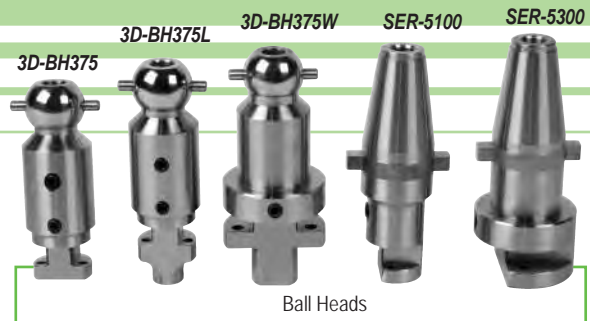

Ball Heads



Watch an overview of the 3-D Fast Cut™ System in our Tech Lab Tuesday video. Scan the code below with your smart phone for quick access.

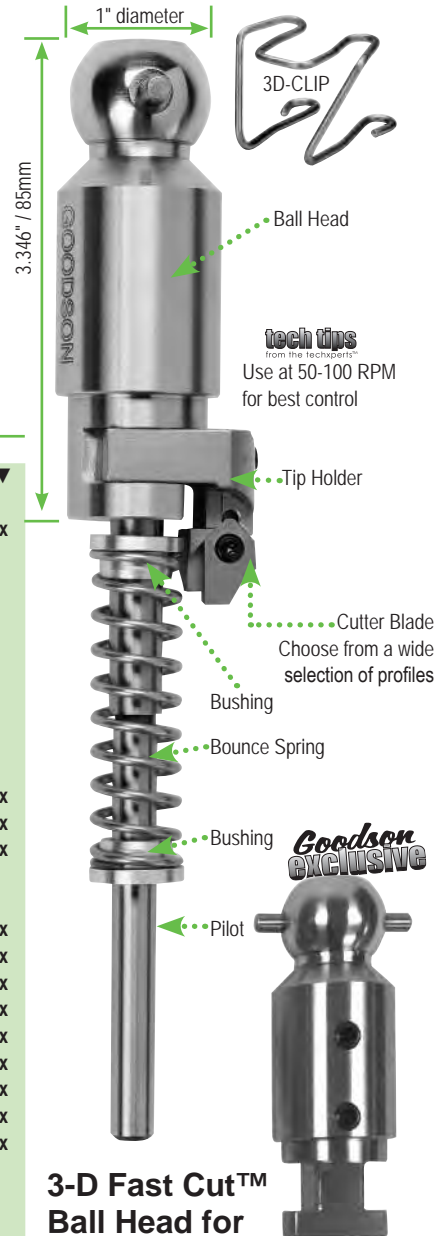

3-D Fast Cut™ Ball Head for Sunnen Tool Holders

- Exclusively from Goodson
- Fits .375" Top pilots, giving you easy access to a wide range of pilot sizes • Tool Holder channel measures .500"
- Use with insert holders SGM-1045, SGM-1055, SGM-1090 and SGM-1115
- 3.350" long x 1.162" diameter
- Order No. **3D-BH-SUN375**
Jobber \$369.99

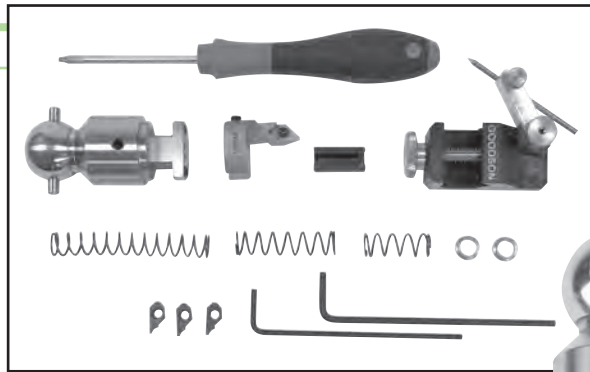

Holders (3DH-1995 & 3DH-1999M) have been modified to provide support to cutters without interfering with the bowl diameter.

Micro Tips FTM-190 and FTM-82R6B-HP only fit Tip Holder 3DH-1995

3-D Fast Cut™ System Micro Ball Head Tooling

- Fits the same 1" ball head driver as the original 3-D Fast Cut tooling
- See page 7 for .236" Top Pilots

Description	Jobber	Order No.	
Micro Ball Head Starter Kit	\$919.99	3D-236-KIT	▼
3D Ball Head for .236"/6mm Pilot (2.56"L)	249.99	3D-BH236	x
Micro Cutter Tips 45°/1.0mm	59.99	FTM-185	x
See pg. 11 45°/1.0mm	59.99	FTM-187	x
for profiles 39°/1.0mm	59.99	FTM-188	x
90° (For counterboring)	59.99	FTM-190	x
82° Radius Cutter	59.99	FTM-82R6B-HP	x
Tip Holders .550"-.984" Range	219.99	3DH-1999M	x
.551"-.850" Range	219.99	3DH-1995	x
Bounce Springs Short 1.050" / 26.7mm	15.99	3D-BS1	x
.340" ID Medium 1.540" / 39.2 mm	15.99	3D-BS3	x
.420" OD Long 2.550" / 64.8 mm	15.99	3D-BS2	x
Bounce Spring Bushing (1 pair)	20.99	3D-BB1	x
Bounce Spring Spacer 22mm long	37.99	3D-BB2	x
3-D Fast Cut™ Accessories			
Replacement 2.5mm Hex Key	\$1.99	3D-2.5	x
Replacement Side Screw M5x8MM	4.99	3D-58	x
Replacement Base Screw M5x5MM	1.99	3D-55	x
Cutter Blade Mounting Screw	5.99	FT-SCREW	x
Blade Wrench	12.49	FT-WRENCH	x
Tool Setting Fixture	159.99	3D-TSFA	x
Bridgeport / DCM Ball Head Driver	359.99	3D-3/4SS	x

Valve Guide Level

- Graduated vials with satin-chromed, brass protective covers that rotate to close tightly
- Base castings are seasoned, then precision machined and finished on a bearing surface • Replaceable vials
- Adjustable for precise calibration
- 1 division equals .0005" per inch
- Fits pilots from 6mm to .437"



VGL-100
(use with your pilot or find on page 5)

Description	Jobber	Order No.	Replacement Vial
4" Valve Guide Level (3" vial)	\$294.99	VGL-100	\$161.99 VGL-101

See goodson.com for level calibration instructions



Valve Seat Removal Tooling

- Fits most popular 3-angle cutting tools including our popular 3-D Fast Cut™ System, Kwik-Way, Peterson, Rottler, Serdi, T&S, Winona Van Norman, Newen, etc.
- Use to relieve press fit for easier seat removal
- Requires a minimum of 2 cuts
- For precise set up use the MGA-MIC (below)

- Tip Holders include one cutting tip and mounting screw (see chart below) • Replacements sold separately
- Ball Head and Drive Tools sold separately (see page 8)

Description	Replacement Tip	Jobber	Order No.	
Tip Holders	3DB-1999i	\$279.99	3D-1999C	
	3DB-250	269.99	3D-2000C	
	3DB-250	269.99	3D-2001C	
	3DB-250	269.99	3D-2002C	
Wide Body Tip Holders	3DB-250	389.99	3D-2003C	
	3DB-250	389.99	3D-2004C	
Replacement Tip		54.99	3DB-1999i	
		48.99	3DB-250	
Replacement Screw	for 3DB-1999i	16.99	3DB-1999S	
	for 3DB-250	15.99	3DS-SCREW	
Cutting Range with Pilot Size				
Holder	.236" Top	.375" Top	.385" Top	.437" Top
3D-1999C	0.960"-1.225"	1.095"-1.360"	1.105"-1.360"	1.157"-1.360"
3D-2000C	1.056"-1.480"	1.194"-1.480"	1.206"-1.480"	1.264"-1.480"
3D-2001C	—	1.376"-2.000"	1.386"-2.000"	1.450"-2.000"
3D-2002C	—	1.524"-2.460"	1.544"-2.460"	1.610"-2.460"
3D-2003C	—	1.680"-2.400"	1.680"-2.400"	—
3D-2004C	—	2.280"-3.200"	2.280"-3.200"	—

.375" Precision Drill Bushing for standard or pilot
MGA-MIC-1S Precision ground and micro polished stabilized tool steel



new design

3-D Fast Cut Setting Micrometer

- Direct reading micrometer accurate to .001"
- Uses tapered .375" Pilot to match your ball head (sold separately)
- Use to set cutting diameter of 90° carbide cutters when modifying counterbores
- Use the optional calibration standard to ensure your micrometer is reading correctly

Description	Cutting Range	Jobber	Order No.
Standard Micrometer	0.800" - 2.800"	\$449.99	MGA-MIC
Calibration Standard		74.99	MGA-MIC-1S

CYLINDER HEAD REBUILDING

CLEANING, ASSEMBLY & SAFETY

SHORT BLOCK REBUILDING

FLYWHEEL GRINDING CRANKSHAFT/

MISCELLANEOUS TOOLS & SUPPLIES

BRAKE SERVICE TOOLING

MEASURING TOOLS

V-TWIN & METRIC HARD PARTS



SABER TOOTH SERIES CUTTER BLADES

Cutter Key:

- I** Intake
- E** Exhaust
- S** Specialty

High Performance Cutter Blades Add 10 to 20 CFM to Cylinder Heads

Designed to increase airflow by as much as 20 CFM, these cutters are intended for certain applications. Generally you should use intake cutters on intakes and exhaust on exhausts, but as with most things, there's always an exception. Experiment to find the right combination for you and your customers.



All Cutters This Page Jobber \$54.99 each

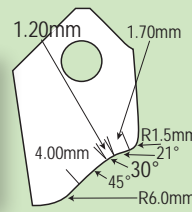

I IFT-30B-HP

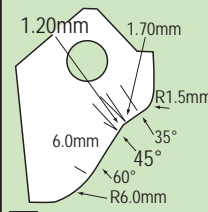

I IFT-4560B-HP

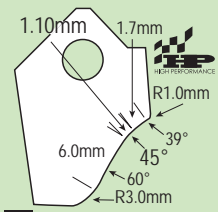

I IFT-4539B-HP

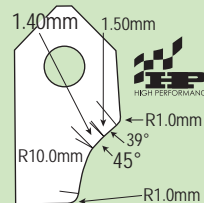

E IFT-4524-HD

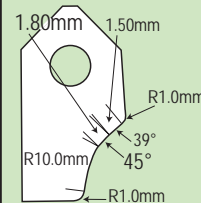

E IFT-4524A-HD

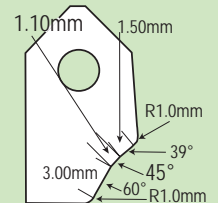

I IFT-4560-HD

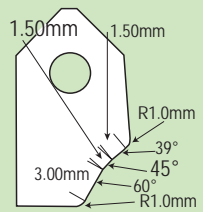

I IFT-4560A-HD

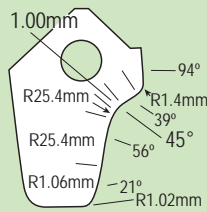

E IFT-4556B-HP

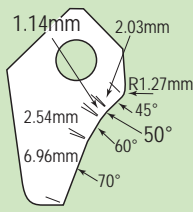

I EFT-5060B-HP

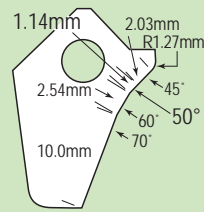

I EFT-5061B-HP

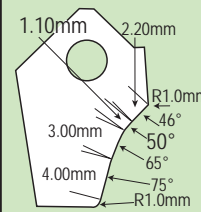

I IFT-5065B-HP

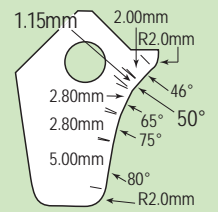

I EFT-5046B-HP

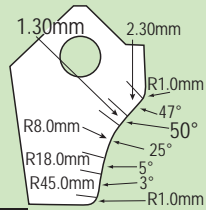

E IFT-5025B-HP

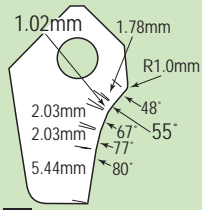

I EFT-5567B-HP

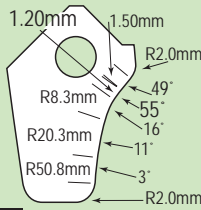

E EFT-5557B-HP

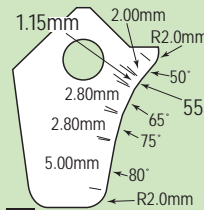

I EFT-5550B-HP

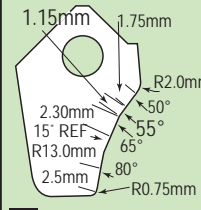

I EFT-5565B-HP

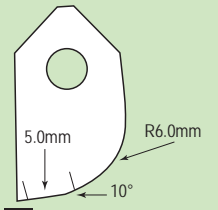

S IFT-1056-HD

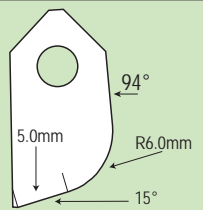

S IFT-1556-HD

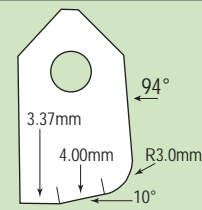

S IFT-1043-HD

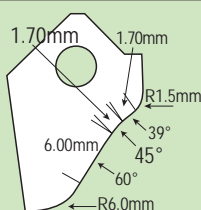

I IFT-45B-HP



SABER TOOTH SERIES CUTTER BLADES

Increase Flow &
Improve
Horsepower

Enlarged to show details

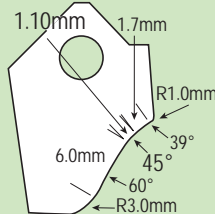

IFT-4539B-HP
Intake

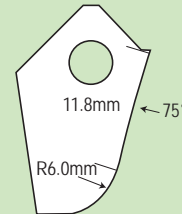

IFT-75R6B-HP
Follow up Intake

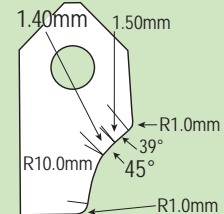

IFT-4524-HD
Exhaust

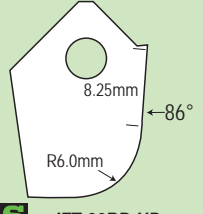

S IFT-86RB-HP

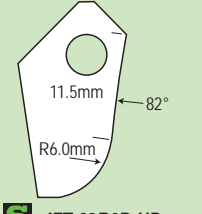

S IFT-82R6B-HP

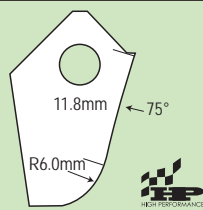

S IFT-75R6B-HP

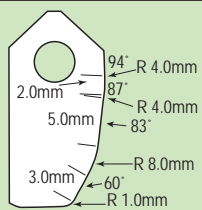

E RBP-RR4

3-Pc. Set High Performance Valve Seat Cutters

- Increase flow & improve horsepower with this set
- Machine your intake seat with **IFT-4539B-HP** then use cutter **IFT-75R6B-HP** to machine below the seat and blend into the port
- On exhaust, machine with **IFT-4524-HD**
- Order No. **IFT-HP-SET** Jobber \$134.99



CYLINDER HEAD
REBUILDING

CLEANING,
ASSEMBLY & SAFETY

SHORT BLOCK
REBUILDING

CRANKSHAFT/
FLYWHEEL GRINDING

MISCELLANEOUS
TOOLS & SUPPLIES

BRAKE SERVICE
TOOLING

MEASURING
TOOLS

V-TWIN & METRIC
HARD PARTS



SABER TOOTH
SERIES CUTTER BLADES

3-D Radius Profile Seat Cutter Blades

3-D Fast Cut Tool Holder

- Use when sharpening cutter blades to keep the cutter in the correct position
- Order No. **3D-HOLDER**
Jobber \$43.99



Cutter Key:

- I** Intake
- E** Exhaust
- S** Specialty



Diamond Hand Files

- Use for fine touch-ups on your Seat Cutter Blades

Description	Jobber	Order No.
Diamond File	\$70.99	DFS-2
Set -1-360 grit & 1-600 grit		
600 Grit Files	70.99	DFS-6
(2-pack)		

Custom Cutter Blades Are Easy!

- 1 Download the **Goodson Custom Formtool Profile Form** from our website (scan the code at right with the camera on your smart phone or other smart device) or call to have us send a copy.
- 2 Complete the form, including a drawing of the cutter you need. Be sure to include all angles, radii, seat widths, etc. Missing information will delay your cutter or result in an incorrect profile.
- 3 Select cutter material. Standard Carbide (21 day lead time) or Saber Tooth Series Alloy (30 day lead time).
- 4 Send the completed form to Goodson. Fax: 888-466-3909 or E-mail: orderdesk@goodson.com. We'll get a blueprint made which you must approve before we start production. Standard Carbide Custom Cutter Prices Start at \$114.99
Saber Tooth Alloy Custom Cutter Prices Start at \$129.99



Turn the Page for More Valve Seat Cutter Blades

Cutter Blades This Page
Jobber \$54.99
Micro Cutter Blades
Jobber \$59.99

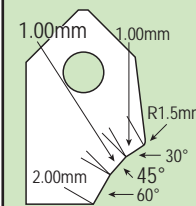

I FT-5043A-HD

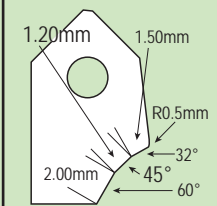

I FT-4247A-HD

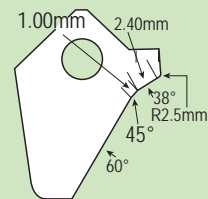

I FT-068B-HP

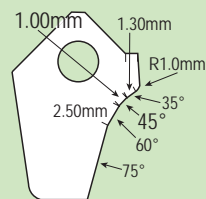

I FT-069B-HP

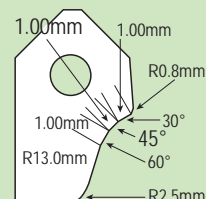

I FT-5118A-HP

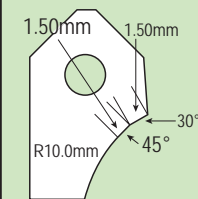

I FT-5119A-HP

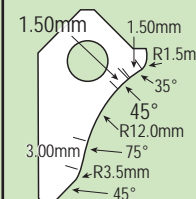

E FT-003B-HP

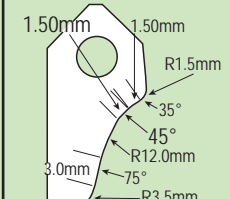

E FT-004B-HP

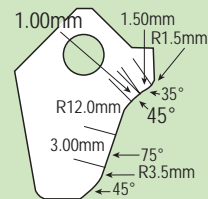

E FT-005B-HP

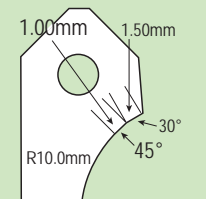

E FT-5120A-HP

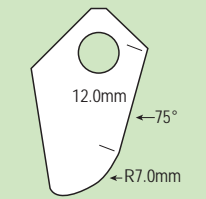

S FT-002B-HP

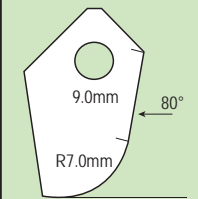

S FT-033B-HP

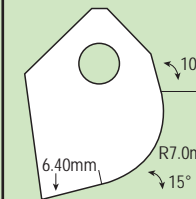

S FT-077B-HP

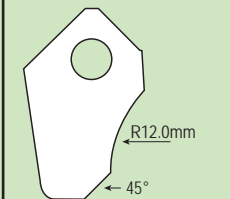

S FT-084B-HP

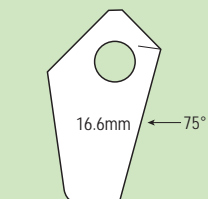

S FT-085B-HP

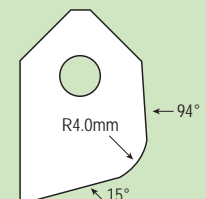

S FT-5121A-HP

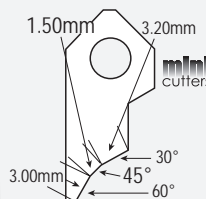

S FT-213B-HP

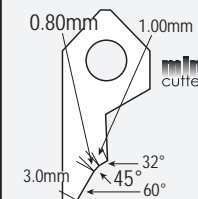

S FT-215B-HP

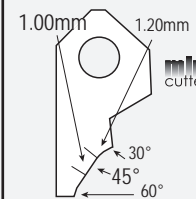

S FT-4028B-HP

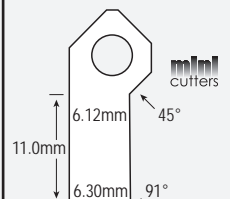

S FT-9020B-HP

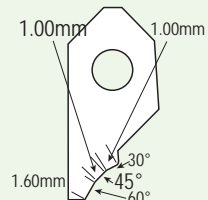

S FTM-185

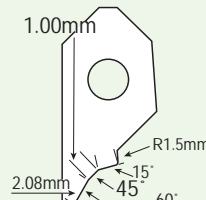

S FTM-187

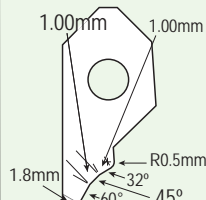

S FTM-188

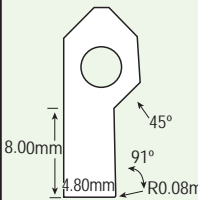

S FTM-190

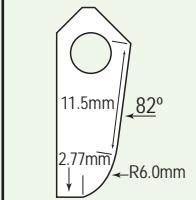

S FTM-82R6B-HP

Micro Blades
Work with holders on page 9
Jobber \$59.99 ea.

CYLINDER HEAD REBUILDING
CLEANING, DISASSEMBLY & SAFETY
SHORT BLOCK REBUILDING
CRANKSHAFT/ FLYWHEEL GRINDING
MISCELLANEOUS TOOLS & SUPPLIES
BRAKE SERVICE TOOLING
MEASURING TOOLS
V-TWIN & METRIC HARD PARTS



3-D Multi-Angle Seat Cutter Blades

SABER TOOTH SERIES CUTTER BLADES

All Valve Seat Cutter Blades This Page Jobber \$44.99 ea.

CYLINDER HEAD REBUILDING

CLEANING, ASSEMBLY & SAFETY

SHORT BLOCK REBUILDING

CRANKSHAFT/ FLYWHEEL GRINDING

MISCELLANEOUS TOOLS & SUPPLIES

BRAKE SERVICE TOOLING

MEASURING TOOLS

V-TWIN & METRIC HARD PARTS

45° Seat Angle Cutter Blades \$44.99 each

30° Seat Angle Cutter Blades \$44.99 each

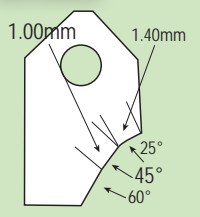

FT-45039U1

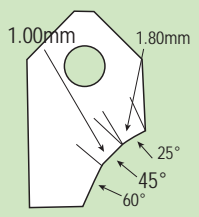

FT-45039U2

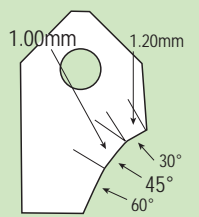

FT-45039V1

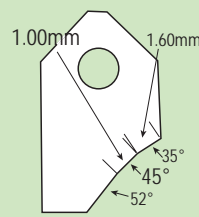

FT-45039W1

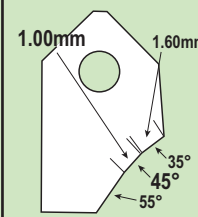

FT-45039W2

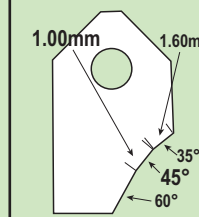

FT-45039W3

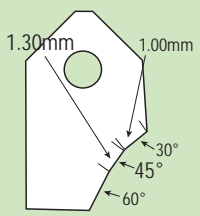

FT-45051V2

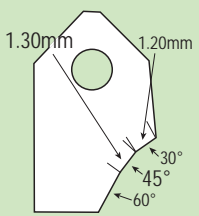

FT-45051V4

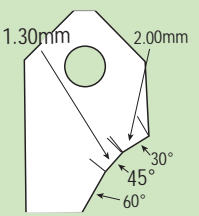

FT-45051V1

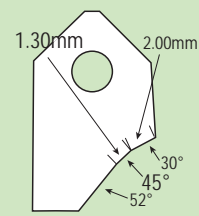

FT-45051V3

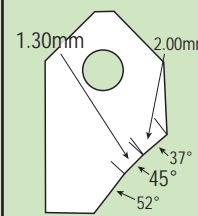

FT-45051X1

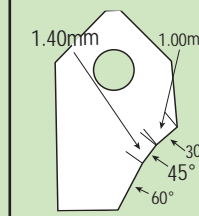

FT-45055V1

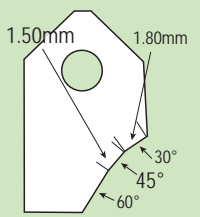

FT-45059V1

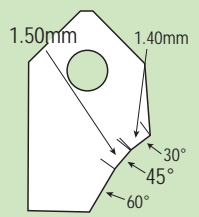

FT-45059V2

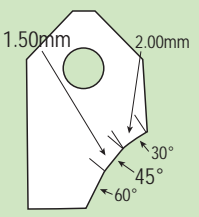

FT-45059V3

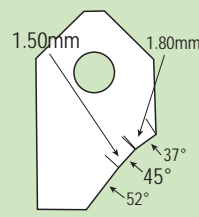

FT-45059X1

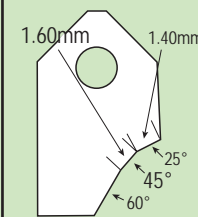

FT-45063U1

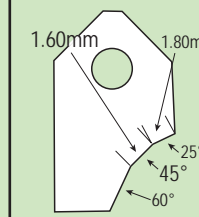

FT-45063U2

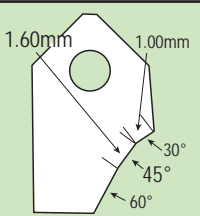

FT-45063V1

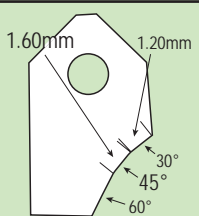

FT-45063V3

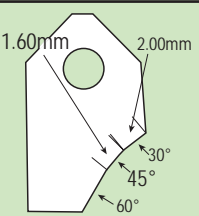

FT-45063V2

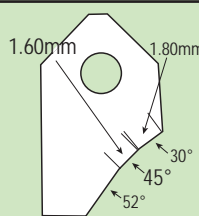

FT-45063W1

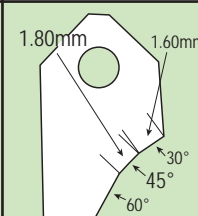

FT-45071V1

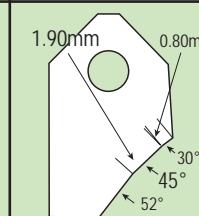

FT-45075V2

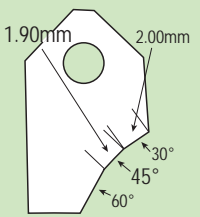

FT-45075V1

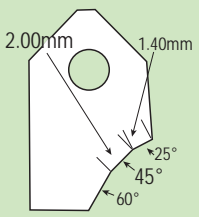

FT-45079U1

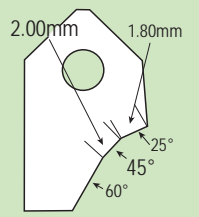

FT-45079U2

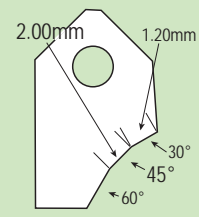

FT-45079V1

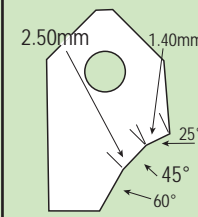

FT-45098U1

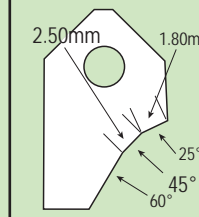

FT-45098U2

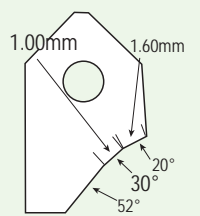

FT-30039T1

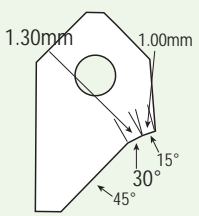

FT-30051S1

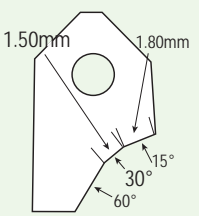

FT-30059S1

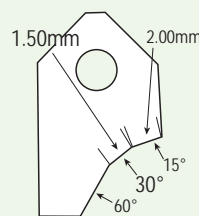

FT-30059S3

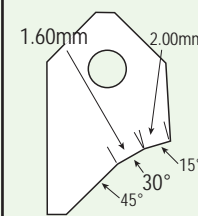

FT-30063S1

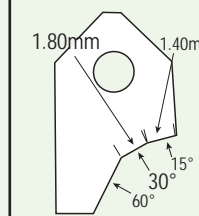

FT-30071S1

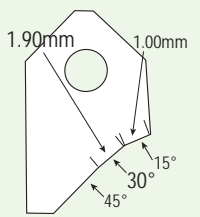

FT-30075S1

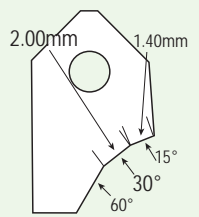

FT-30079S1

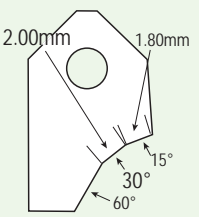

FT-30079S2

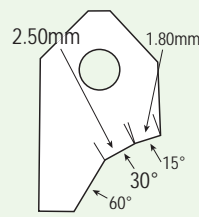

FT-30098S1

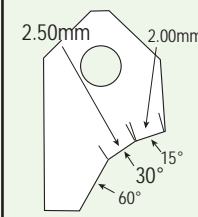

FT-30098S2

resharpening
available

**Have Goodson
Resharpen
Your Valve Seat
Cutter Blades**

Single Angle Valve Seat Cutter Blades Jobber \$44.99 ea.



**SABER TOOTH
SERIES CUTTER BLADES**

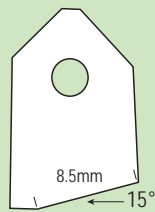

FT-15

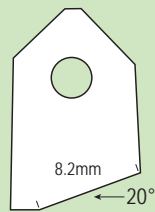

FT-20

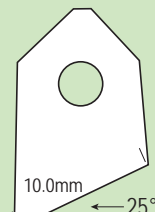

FT-25

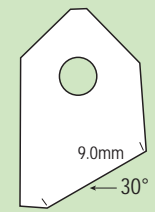

FT-30

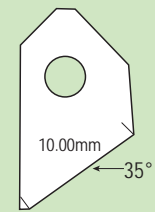

FT-35

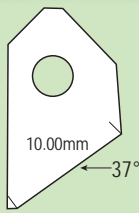

FT-37

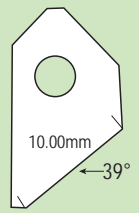

FT-39

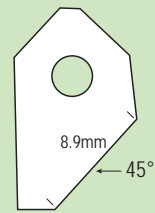

FT-45

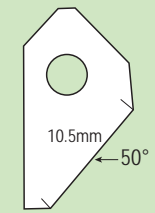

FT-50

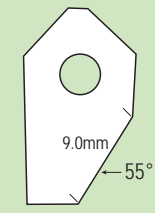

FT-55

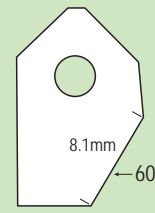

FT-60

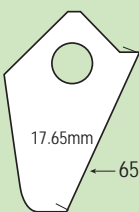

FT-65

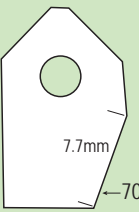

FT-70

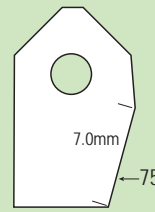

FT-75

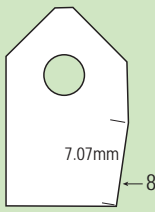

FT-82

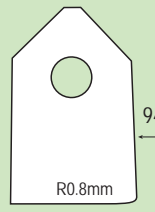

FT-90

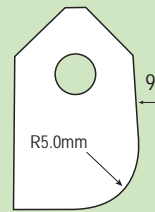

FT-R5

sized for **diesel**
Diesel Blades
Jobber \$54.99

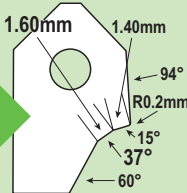

FT-37063S60

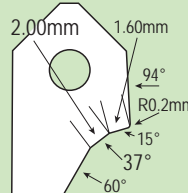

FT-37079S60

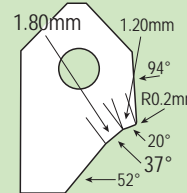

FT-37071S52

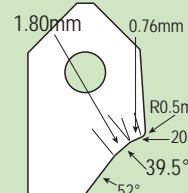

FT-39570T1

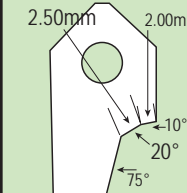

FT-20098S1



- Increase Low Lift Air Flow
- Increase Torque
- Increase Horsepower

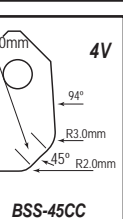
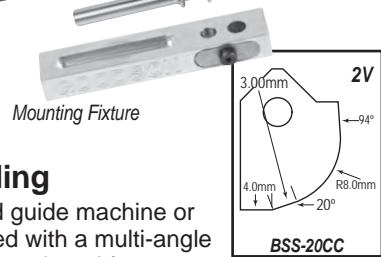

Diesel Relief Tooling

- Use with your seat and guide machine or Bridgeport Mill equipped with a multi-angle seat cutting system
- Developed for Goodson by Joe Mondello Racing Engines
- Use for 6.0L & 7.3L Ford, 12 Valve, 5.9L Cummins & 6.6L Duramax diesel engines
- For 2-Valve & 4-Valve heads • Complete kit includes the Mounting Fixture, .375" Top Offset Pilot, Indexing Pin & Radius Cutter
- This tool is only for use with radius cutters BSS-20CC and BSS-45CC

Description	Jobber	Order No.	Incl.
7mm Diesel Relief Tool Kit	\$184.99	DVRT-7MM-KIT	▼
8mm Diesel Relief Tool Kit	184.99	DVRT-8MM-KIT	▼
20CC Radius Cutter for 2-Valve Heads	54.99	BSS-20CC	x
45CC Radius Cutter for 4-Valve Heads	54.99	BSS-45CC	x

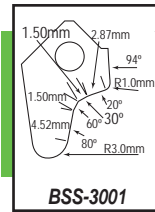

BSS-3001

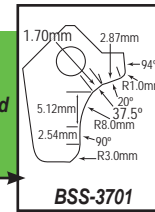

BSS-3701

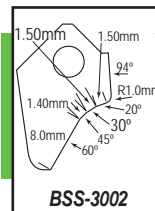

BSS-3002

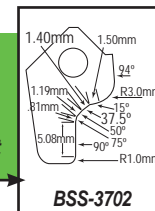

BSS-3702

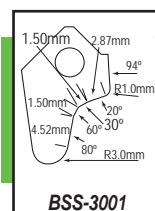

BSS-3001

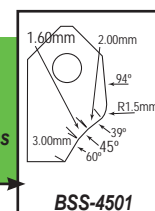

BSS-4501

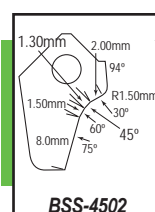

BSS-4502

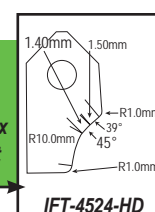

IFT-4524-HD

black smoke
series cutters
for High Performance Diesel Engines

Developed for Goodson by Joe Mondello Racing Engines. These cutters are designed to be used with your 3-D Fast Cut or other multi-angle tooling. Jobber \$54.99 ea.



See How to Use the Diesel Relief Tooling on YouTube! Search for Diesel Valve Relief Tool.

CYLINDER HEAD REBUILDING
CLEANING, ASSEMBLY & SAFETY
SHORT BLOCK REBUILDING
CRANKSHAFT/ FLYWHEEL GRINDING
MISCELLANEOUS TOOLS & SUPPLIES
BRAKE SERVICE TOOLING
MEASURING TOOLS
V-TWIN & METRIC HARD PARTS

... another satisfied customer

"It has been a long time since I have seen such a great vendor as these people. They are simply great. I give them an A+++ rating and hope to deal with them more."

- Wayne Hudson, Hillboro, Oregon (via Facebook), Goodson customer since 2014

CYLINDER HEAD REBUILDING

CLEANING, ASSEMBLY & SAFETY

SHORT BLOCK REBUILDING

CRANKSHAFT/ FLYWHEEL GRINDING

MISCELLANEOUS TOOLS & SUPPLIES

BRAKE SERVICE TOOLING

MEASURING TOOLS

V-TWIN & METRIC HARD PARTS

3-D FAST CUT™ SYSTEM

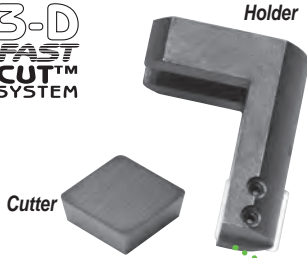

3-D Fast Cut Adjustable Spring Pad Cutters

- No need to change tooling, just change the tool holder and start cutting spring pads
- Works with all popular 3-angle cutting systems
- Square blades are indexable and replaceable
- Tool holder includes one blade



Tool Holders			
Blade Size	Application	Jobber	Order No.
3/8" / 9.53mm	All except Sunnen®	\$229.99	SPC-375
1/2" / 12.70mm	All except Sunnen®	249.99	SPC-500
Replacement Carbide Cutters (for all holder styles above)			
3/8" / 9.53mm		\$20.99	SPCI-375
1/2" / 12.70mm		22.99	SPCI-500
Accessories			
Lift Clip for Enhanced Control		\$24.99	3D-CLIP

Valve Spring Seat Cutters on Page 48



Minnesota Fast Freeze

- Instantly chills seats & guides to -50° F (-45.5° C)
- Creates interference fit with heated aluminum heads
- Finish seat and guide work faster than ever
- Aerosol*
- Use on tight bushings, pins, shafts, etc.
- 10 oz. can

Description	Jobber 1+	Jobber 6+	Order No.
Minnesota Fast Freeze	\$38.99	\$35.09	MFF-8

Order 6 or more to Save 10% off Jobber

*Hazardous Goods Fees Apply When Shipped by Air

Press Fit Lubricants

- A light coat eases press fit
- Ideal for valve guides, piston pins, cylinder sleeves, etc.
- Eliminates the scoring, gouging and galling of parts during press fitting

Description	Jobber 1+	Jobber 6+	Order No.
Goodson Aerosol 6 oz. (170 g)	\$13.99	\$12.59	PFL-200*
Sunnen® Aerosol 7 oz. (198 g)	21.27		B-200*
Sunnen® Brush Applicator 200 mL	28.93		B-200L*

*Hazardous Goods Fees Apply When Shipped By Air
Save 10% by buying 6 or more cans of PFL-200



3-D Fast Cut™ Bowl Profiler

- Machine seats & bowls on a pair of V8 heads in about 40 minutes
- Remove material to contour cylinder head bowl areas and unshroud valves in combustion chambers
- Will not work with Sunnen® Ball Heads

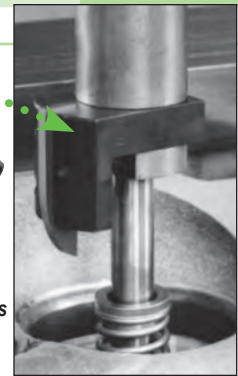

Holder Diameter Range	Jobber	Order No.
1.25"-1.87" / 32-48mm	\$199.99	NBN-1
1.57"-2.13" / 40-54mm	199.99	NBN-2

Blades sold separately

NBN-5 \$92.99	NBN-6 \$92.99	NBN-12 \$134.99	NBN-14 \$134.99	NBN-15 \$134.99

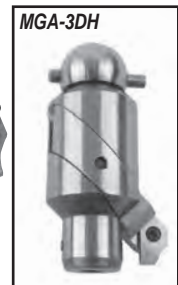
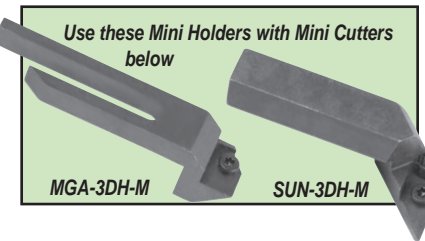
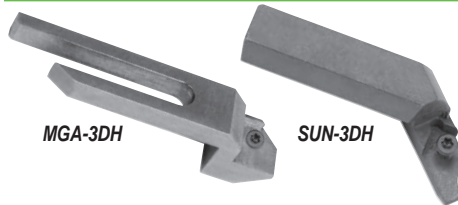

Convert your Sunnen® or Mira® brazed cutters to 3-D with this simple holder

This blade holder allows you to mount premium, replaceable carbide cutters on your existing MIRA® and Sunnen® ball-type tool holders. Choose from our wide selection of replaceable cutters, previously only available for 3-D Fast Cut™ or similar seat cutting systems.

Description	Jobber	Order No.
Standard Cutter	\$189.99	MGA-3DH
Holders	194.99	SUN-3DH
Mini Cutter	189.99	MGA-3DH-M
Holders	194.99	SUN-3DH-M
Mini Cutters	54.99	FT-213B-HP
	54.99	FT-215B-HP
view profiles	54.99	FT-4028B-HP
on page 11	54.99	FT-9020B-HP
Replacement Screw	5.99	FT-SCREW

Valve Seat Work

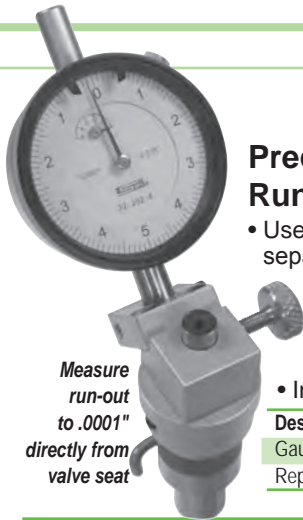

Precision Valve Seat Run-Out Gauge

- Use with your .375" Top Pilot (sold separately) • Measure run-out to .0001" directly from the seat • Locked to the pilot • Dial indicator remains stationary while rotating contact pointer • .800" - 2.500" dia. range • Includes 2" dia. dial indicator

Description	Jobber	Order No.
Gauge Assembly	\$659.99	SCG-375
Replacement Indicator	169.99	SCG-IND

Measure run-out to .0001" directly from valve seat



Valve Seat Machining Aid

- Machine valve seats to a mirror-like finish
- Universal - works with any type of cylinder head machining center
- Use full strength
- Safe for metal surfaces
- Works with mineral-based cutting oils, not water based
- Quart (946mL)
- Order No. **PF-2020** Jobber \$51.99



Layout Fluids

- Choose from blue and red
- Toluene-free • Dries in minutes
- Provides a thin film without cracking or chipping • Prevents glare with a uniform, deep color
- 2 oz. markers feature felt tip applicator
- 4 oz. containers includes brush in cap

Description	Color	Jobber	Order No.
2 oz. Layout Fluid Markers	Blue	\$13.99	VBF-2
	Red	13.99	VRF-2
4 oz. Layout Fluid	Blue	13.99	VBF-4
	Red	13.99	VRF-4



Spray Bluing Fluid

- Fast drying • Will not rub off
- Good adhesion to all metals and glass
- Non-corrosive • Resists heat
- No flaking or peeling
- Scribes clean lines for precision work
- Eliminates rags, daubers, spilled bottles
- Dries to a smooth level coating
- Aerosol*
- Order No. **SBF-16*** Jobber 1+ \$11.99 ea. Jobber 6+ \$10.79 ea.



*Hazardous Goods Fees Apply When Shipped by Air

Now With Easier To Read Gauge



Premium Valve Seat Run-Out Gauges

VSG-375-XL

- Hardened guide bushings & contact pilot • Quick thumb screw set-up
- Jeweled bearing indicator reads to ±.050" with .001" precision
- Range: 1.00"-2.50"
- Measures concentricity



Pilot Size	OAL	Jobber	Order No.
.375"	5"	\$259.99	VSG-375
.385"	5"	259.99	VSG-385
.375" Extended	12 1/2"	549.99	VSG-375-XL
Replacement Indicator		79.99	VSG-IND

Valve and Seat Scribe Tool

- Fits .375" Top Pilot
- Kit includes: tool body, scribe, 1 pilot sleeve, and 6.6mm, 8.0mm, 5/16", 1 1/32" and 3/8" valve stem sleeves • Sleeves fit tool body to valve stems & pilots • Use valve to set point then scribe seat with inner & outer radii (valve not included) • Grind seat top & throat to match face precisely
- Order No. **ST-30-BD** Jobber \$37.99



Cutting & Tapping Fluid

- Cut through even the hardest metals
- Spray clings to the surface of the tool to prolong tool life
- Ideal for stainless steel, high nickel alloys, titanium and more
- Use for reaming, seat cutting and CBN cutting
- Aerosol*
- Order No. **CTF-14*** Jobber 1+ \$13.99 ea., Jobber 6+ \$12.59 ea.

*Hazardous Goods Fees Apply When Shipped by Air
Order 6 or more CTF-14, save 10% off jobber



Prussian Blue Paste

- Aids precision fitting of machined surfaces
- Locates high spots on bearings, valves, gears and other close-tolerance components
- Non-drying, easy clean-up
- Coat parts with a uniform film of Prussian Blue; assemble in working position and turn shaft; improper fit will show up as easy-to-see bright blue streaks
- 0.75 fl. oz. tube
- Order No. **PB-75** Jobber \$10.99



CYLINDER HEAD REBUILDING
CLEANING, ASSEMBLY & SAFETY
SHORT BLOCK REBUILDING
CRANKSHAFT/ FLYWHEEL GRINDING
MISCELLANEOUS TOOLS & SUPPLIES
BRAKE SERVICE TOOLING
MEASURING TOOLS
V-TWIN & METRIC HARD PARTS

Neway Valve Seat Cutting System

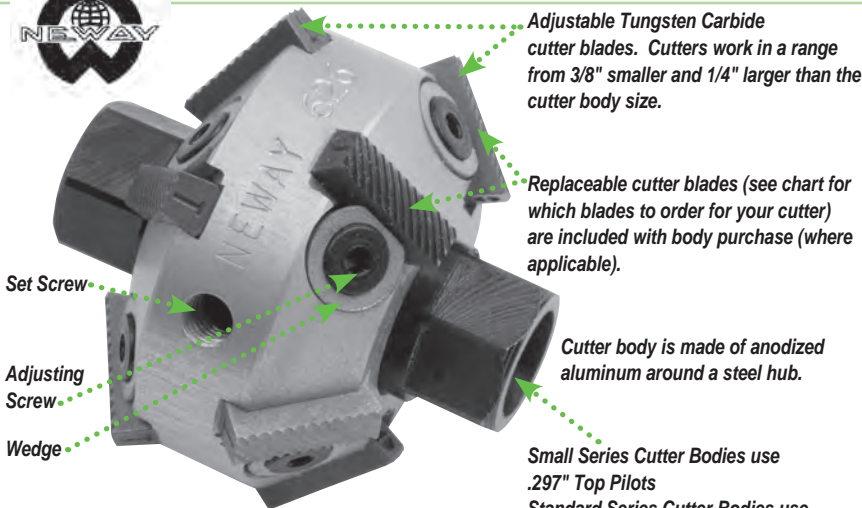

Adjustable Tungsten Carbide cutter blades. Cutters work in a range from 3/8" smaller and 1/4" larger than the cutter body size.

Replaceable cutter blades (see chart for which blades to order for your cutter) are included with body purchase (where applicable).

Cutter body is made of anodized aluminum around a steel hub.

Small Series Cutter Bodies use .297" Top Pilots
Standard Series Cutter Bodies use .375" Top Pilots (page 5)

Many cutter body styles available including single angle and double angle for a variety of cutting applications.

special order

Don't see the cutter you need in the chart below? Goodson can order any Neway Cutter Body and tooling available.

Replacement Blades & Parts

Enlarged For Detail

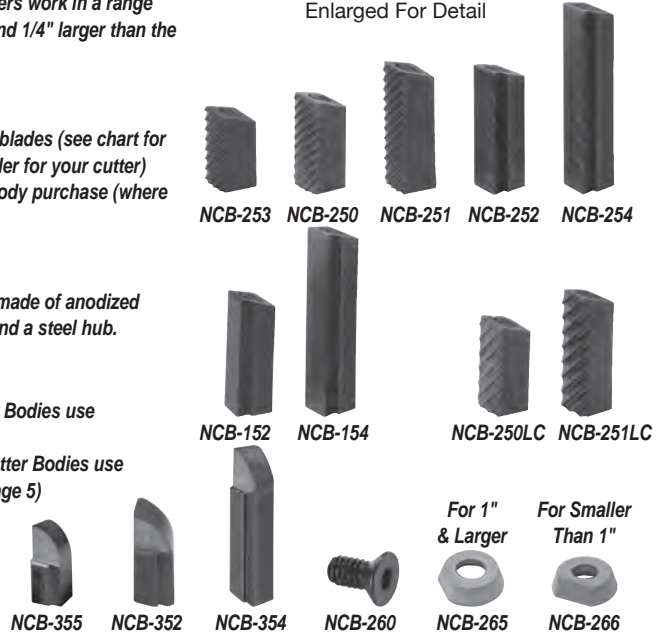

Description	Jobber	Order No.
Small Series Cutter Bodies (Use .297" Top Pilots - page 5)		
Cutter Body	Blade	Qty. Replacement Blade
0.975" / 24.8mm	45°	3 NCB-253 \$97.99
1.000" / 25.4mm	60°	3 NCB-252 97.99
1.312" / 33.3mm	15°/60°	3/3 NCB-251, -254 161.99
Replacement Blades	Angle	Blade Length
Blades	15-46°	5/16" / 7.9mm \$11.99
	Sold	3/8" / 9.53mm 11.99
	Individually	1/2" / 12.7mm 11.99
		60-75° 1/2" / 12.7mm 11.99
		3/4" / 19.05mm 11.99
Non-Serrated	60-75°	1/2" / 12.7mm 11.99
Correction Blades		3/4" / 19.05mm 11.99
Hard Seat	15-46°	3/8" / 9.53mm 11.99
Blades		1/2" / 12.7mm 11.99
Radius Combustion		3/8" / 9.53mm 21.99
Chamber Blades		1/2" / 12.7mm 21.99
		3/4" / 19.05mm 21.99
Flat Head Screw		1.99
Wedge for bodies 1" / 25.4mm and over		1.99
Wedge for bodies smaller than 1" / 25.4mm		1.99
Tool Kit (includes brush, 2 hex keys and pilot puller)		6.99
EZ-Turn Wrench		87.99
1/2" T-Handle Driver		13.99
3/8" T-Handle Driver		13.99
Drive Adaptor		1/2" to 3/8" / 12.7-9.53mm 13.99

Description	Jobber	Order No.
Standard Series Cutter Bodies (Use .375" Top Pilots - page 5)		
Cutter Body	Blade	Qty. Replacement Blade
1.125" / 28.6mm	30°	3 NCB-250 \$ 95.99
	45°	3 NCB-250 95.99
	60°	3 NCB-252 95.99
	37.5°	5 NCB-250 139.99
1.250" / 31.6mm	30°/45°	3/3 NCB-250 159.99
	31°/46°	3/3 NCB-250 156.99
	60°	3 NCB-252 95.99
1.375" / 35.0mm	30°/45°	3/3 NCB-250, -251 159.99
1.500" / 38.0mm	15°/75°	3/3 NCB-251, -254 159.99
	30°/45°	3/3 NCB-251 161.99
	30°/45°	5/5 NCB-251 264.99
	40°	5 NCB-251 144.99
	60°	3 NCB-254 96.99
1.750" / 44.5mm	15°/60°	5/5 NCB-251, -254 264.99
	30°/45°	5/5 NCB-251 264.99
	55°	5 NCB-251 236.99
2.000" / 50.8mm	15°/60°	5/5 NCB-251, -254 264.99
	30°/46°	5/5 NCB-261 264.99
	60°	5 NCB-254 143.99
2.500" / 63.5mm	30°/45°	7/7 NCB-251 339.99
	50°	7 NCB-251 259.99
	52°	7 NCB-251 274.99
	55°	7 NCB-251 259.99



T-Handle

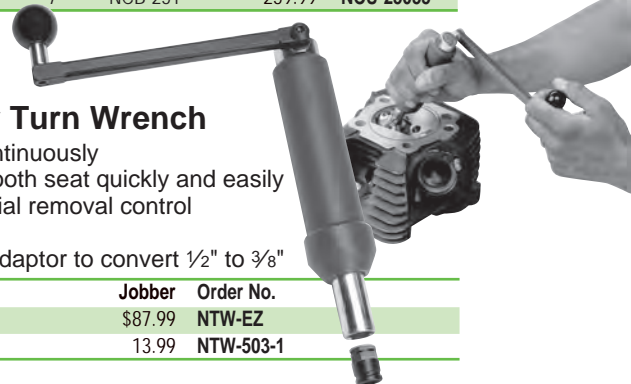

Valve Seat Cutting Fluid

- High silicone content reduces drag on cutters so they last longer
- Promotes smoother cuts
- May be diluted up to 9:1
- Non-aerosol spray

Size	Jobber	Order No.
16 oz. Spray / 473 mL	\$14.99	SCF-2
1 Gal. / 3.79 L	31.99	SCF-10



Neway Easy Turn Wrench

- Turn cutters continuously
- Produces a smooth seat quickly and easily
- Improves material removal control
- Spring loaded
- Includes drive adaptor to convert 1/2" to 3/8"

Description	Jobber	Order No.
Wrench	\$87.99	NTW-EZ
Drive Adaptor	13.99	NTW-503-1

CYLINDER HEAD REBUILDING
CLEANING, ASSEMBLY & SAFETY
SHORT BLOCK REBUILDING
CRANKSHAFT/ FLYWHEEL GRINDING
MISCELLANEOUS TOOLS & SUPPLIES
BRAKE SERVICE TOOLING
MEASURING TOOLS
V-TWIN & METRIC HARD PARTS

Counterboring Tools

GOODSON Counterbore Cutters CUT TRUE TO SIZE!

Other cutters may cut as much as .005" smaller

tech tips from the techxperts™

Goodson recommends using
Indexable Counterbore Cutters
at 40 to 60 RPM.



Indexable Counterbore Cutters

These indexable counterbore cutters eliminate down time from having brazed cutters reset or sharpened. You can service them right in your own shop! Each cutter body includes 2 carbide cutter tips with 4 cutting edges. When one edge wears, simply rotate the tip to a new cutting edge. You'll also get a wrench with every cutter body.



DWI-SERIES

- Fits DCM Tech, Sunnen, and Winona Van Norman
- $\frac{9}{16}$ " / 14.3mm arbor

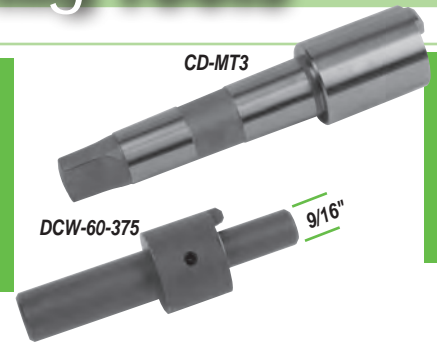

Counterbore Cutter Drive Adaptors

Cutter Drivers	Jobber	Order No.
#3 MT Driver	\$409.99	CD-MT3
Fits .750" Bridgeport Collet		
$\frac{9}{16}$ " arbor, .375" pilot	\$167.99	DCW-60-375
$\frac{9}{16}$ " arbor, .385" pilot	157.99	DCW-60-385

Size	mm	Repl. Insert	Jobber	Order No.
1.062"	26.97	SCI-250-B	\$269.99	DWI-1062
1.125"	28.57	SCI-250-B	269.99	DWI-1125
1.187"	30.15	SCI-250-B	269.99	DWI-1187
1.250"	31.75	SCI-250-B	269.99	DWI-1250
1.312"	33.32	SCI-250-B	269.99	DWI-1312
1.375"	34.93	SCI-250-B	269.99	DWI-1375
1.437"	36.50	SCI-250-B	269.99	DWI-1437
$\frac{1}{4}$ " Replacement Cutting Insert			42.99	SCI-250-B
Replacement Screw for SCI-250-B			7.99	SCS-T7
Allen Wrench for SCS-T7			9.99	SCW-T7

Size	mm	Repl. Insert	Jobber	Order No.
1.500"	38.10	SCI-375-B	\$269.99	DWI-1500
1.562"	39.67	SCI-375-B	269.99	DWI-1562
1.625"	41.28	SCI-375-B	269.99	DWI-1625
1.687"	42.85	SCI-375-B	269.99	DWI-1687
1.750"	42.85	SCI-375-B	269.99	DWI-1750
1.812"	44.45	SCI-375-B	269.99	DWI-1812
1.875"	47.63	SCI-375-B	269.99	DWI-1875
1.937"	49.20	SCI-375-B	269.99	DWI-1937
2.000"	50.80	SCI-375-B	269.99	DWI-2000
2.062"	52.37	SCI-375-B	269.99	DWI-2062
2.125"	53.98	SCI-375-B	269.99	DWI-2125
$\frac{3}{8}$ " Replacement Cutting Insert			59.99	SCI-375-B
Replacement Screw for SCI-375-B			2.19	SCS-T15
Torx Wrench for SCS-T15			6.49	SCW-T15

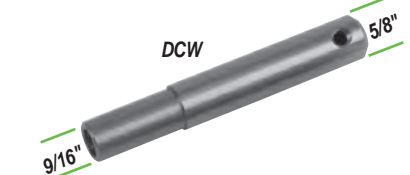

Wear Sleeves for DWA & DWI Counter Bore Cutters

- Wear sleeves fit CD-MT3 Driver

Pilot Top Size	Jobber	Order No.
.375" (9.53mm)	\$82.99	DCW-375
.385" (9.78mm)	82.99	DCW-385



Now with SABER TOOTH Cutter Inserts

Setting Standard

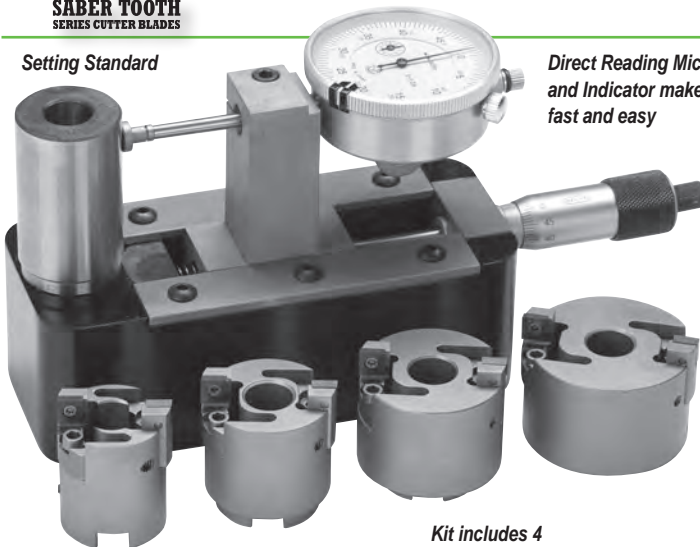

Direct Reading Micrometer
and Indicator makes setting
fast and easy

Kit includes 4
 $\frac{9}{16}$ " Arbor Cutters

GOODSON Adjustable Counterbore Cutter Kit

- Cutter assemblies feature positive stop adjusting screws to prevent cutters from changing dimensions when in use
- Direct reading micrometer and dial indicator for fast, accurate set-up
- 7 cutter assemblies to choose from, covering a range from 1.25" to 2.75" diameter
- Kit substitutions are available, call to inquire
- Heavy duty billet steel construction



Now with SABER TOOTH Cutter Inserts



Scan with your
smart phone or
other device to view



Description	Jobber	Order No.	Incl.
Complete Kit ($\frac{9}{16}$ " / 14.3mm Arbor)	\$1999.99	DWA-300	
Cutter Assemblies (in/mm)			
$\frac{9}{16}$ " Arbor	1.250"-1.375" / 31.8-34.9	\$489.99	DWA-250 x
	1.375"-1.500" / 34.9-38.1	489.99	DWA-375 x
	1.500"-1.750" / 38.1-44.5	489.99	DWA-302 x
	1.750"-2.000" / 44.5-50.8	489.99	DWA-303 x
	2.000"-2.250" / 50.8-57.2	489.99	DWA-304
	2.250"-2.500" / 57.2-63.5	489.99	DWA-305
	2.500"-2.750" / 63.5-69.9	489.99	DWA-306
Cutting Insert	53.99	DKB-7	x
Insert Screw	16.99	DKS-7	x
Wrench	12.49	FT-WRENCH	x
Wear Sleeves (see note below)			
For .375" Top Pilot	\$82.99	DCW-375	
For .385" Top Pilot	82.99	DCW-385	

To use the Counterbore Cutter Kit with Kwik-Way & Peterson Machines you will need to adapt the $\frac{9}{16}$ " cutter to fit the $\frac{5}{8}$ " drive. Use a DCW wear sleeve.

CYLINDER HEAD
REBUILDING
CLEANING,
ASSEMBLY & SAFETY
SHORT BLOCK
REBUILDING
FLYWHEEL, GRINDING
CRANKSHAFT/
TOOLING
MISCELLANEOUS
TOOLS & SUPPLIES
BRAKE SERVICE
TOOLING
MEASURING
TOOLS
V-TWIN & METRIC
HARD PARTS

full service
...fast



"At Goodson, we're trained to know your business. Regular training sessions are held for our entire staff to help us better understand your work so we can provide you with the best possible service."

- Anne, Goodson Accounting - 18 years of service

CYLINDER HEAD
REBUILDING



Traditional Valve Lapping Sticks

- Oil resistant polyethylene handles
- Locking tabs eliminate cup slippage

Description	Cup ID	Jobber	Order No.
Small Lapping Stick 8 1/2" Long		\$8.99	VLS-15
Replacement Cups	15.9mm / 0.625" dia. .156"	5.99	VLS-5/8
	20.6mm / 0.813" dia. .230"	6.99	VLS-13/16
Large Lapping Stick 8 3/4" Long		9.99	VLS-30
Replacement Cups	28.6mm / 1.125" dia. .380"	5.99	VLS-1 1/8
	34.9mm / 1.375" dia. .380"	6.99	VLS-1 3/8

CLEANING,
ASSEMBLY & SAFETY

LOCK
REBUILDING
CRANK
FLYWHEEL
MISCELLANEOUS
TOOLS & SUPPLIES



Valve Seat Inserts

- For Harley-Davidson®
- Easy to machine
- Effectively dissipate heat for consistent valve sealing
- Hardness increases during engine break-in
- Radiused for easy installation



Replacement Valve Seats For Shovel Head 1200 & 1340

Application	OD	ID	Thickness	MSRP	Jobber	Order No.
Exhaust	1.944"	1.575"	.400"	\$10.12	\$7.51	10-HC493
Intake	2.135"	1.750"	.400"	10.12	7.51	10-HC542

Oversize Seats For Shovel, Evolution & Twin Cam - machining required

OD	ID	Thickness	MSRP	Jobber	Order No.
1.630"	1.180"	.385"	\$10.12	\$7.51	10-HC414
1.757"	1.410"	.430"	10.12	7.51	10-HC447
1.882"	1.530"	.410"	10.12	7.51	10-HC478
2.008"	1.610"	.440"	10.12	7.51	10-HC510
2.040"	1.700"	.425"	10.12	7.51	10-HC518
2.070"	1.610"	.460"	10.12	7.51	10-HC526
2.132"	1.800"	.460"	10.12	7.51	10-HC541
2.163"	1.750"	.455"	10.12	7.51	10-HC549

For Iron Head Sportster

Application	OD	ID	Thickness	MSRP	Jobber	Order No.
Exhaust	1.757"	1.371"	.315"	\$10.12	\$7.51	10-HC446
Intake	2.068"	1.750"	.315"	10.12	7.51	10-HC525

Universal Repair Seat

	OD	ID	Thickness	MSRP	Jobber	Order No.
Powdered	1.339"	1.024"	.375"	\$8.89	\$7.51	10-SC340
Metal	1.693"	1.299"	.434"	10.55	7.51	10-SC430
	1.820"	1.375"	.450"	10.12	7.51	10-HC462
	1.945"	1.375"	.440"	10.12	7.51	10-HC494
	2.257"	1.550"	.500"	10.12	7.51	10-HC573

MSRP = Manufacturer's Suggested Retail Price

BRAKE SERVICE
TOOLING

MEASURING
TOOLS

V-TWIN & METRIC
HARD PARTS

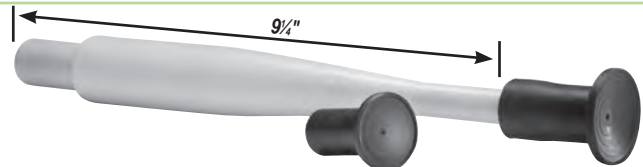

Vacuum Style Lapping Stick

- Press the spring-loaded vacuum pump for a firm hold - stays on until you release the vacuum
- Includes 3 cup sizes (also sold separately)

Description	Cup ID	Jobber	Order No.
Vacuum Lapping Stick 9 1/2" Long		\$37.99	VLV-50
Replacement Cups	19.1mm / 0.750" dia. .415"	8.99	VLV-3/4
	25.4mm / 1.000" dia. .415"	8.99	VLV-1
	31.8mm / 1.250" dia. .415"	9.99	VLV-1 1/4

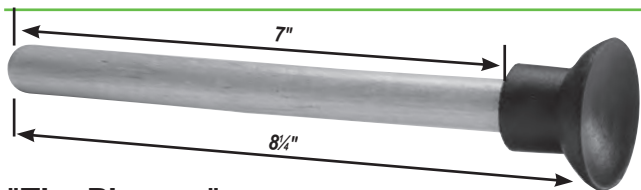

"The Plunger" Hand Valve Lapping Stick

- Large diameter for sure grip
- For 2" and larger valves



Description	Cup ID	Jobber	Order No.
Hand Valve Lapping Stick 8 1/2" Long		\$10.99	VLS-75
Replacement Cup 44.5mm / 1.750" dia.	.313"	6.99	VLS-1 3/4

Buy 12 or more (any combo),
Save 10% off Jobber



Nickel-Chrome Valve Seats



WARNING: This product can expose you to chemicals, including Nickel which are known to the state of California to cause cancer

OD	ID	Depth	Order No.	OD	ID	Depth	Order No.
1.250"	0.812"	1/4"	VS-1250	1.625"	1.375"	1/32"	VS-1625A
1.312"	1.000"	1/4"	VS-1312	1.687"	1.375"	1/4"	VS-1687
1.375"	1.062"	1/4"	VS-1375	1.750"	1.500"	1/4"	VS-1750
1.437"	1.125"	1/4"	VS-1437	1.812"	1.500"	1/4"	VS-1812
1.500"	1.187"	1/4"	VS-1500	1.875"	1.562"	1/4"	VS-1875
1.562"	1.250"	1/4"	VS-1562	1.937"	1.625"	1/4"	VS-1937
1.562"	1.312"	1/32"	VS-1562A	2.000"	1.625"	1/4"	VS-2000
1.625"	1.312"	1/4"	VS-1625	Jobber 1+ each			\$10.99
			Jobber 1+ each				\$10.99
			Jobber 12+ each				9.89

See page 9 for valve seat removal tools
that fit 3-D Fast Cut

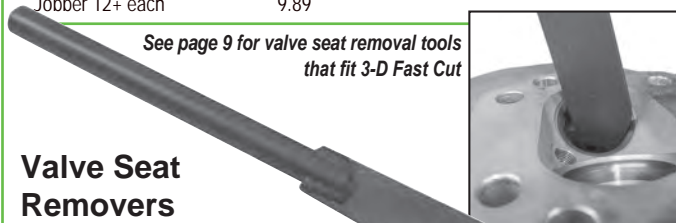

Valve Seat Removers

- Use to pry out valve seat inserts or stubborn grease seals
- Choose from 90°, 100° and 120°, or buy the set
- **Not** recommended for use on aluminum heads
- Set includes one of each angle
- 13 7/8" overall length

Description	Jobber	Order No.
3-Pc. Set	\$129.99	VSP-SET ▼
90°	47.99	VSP-90 x
100°	47.99	VSP-100 x
120°	47.99	VSP-120 x

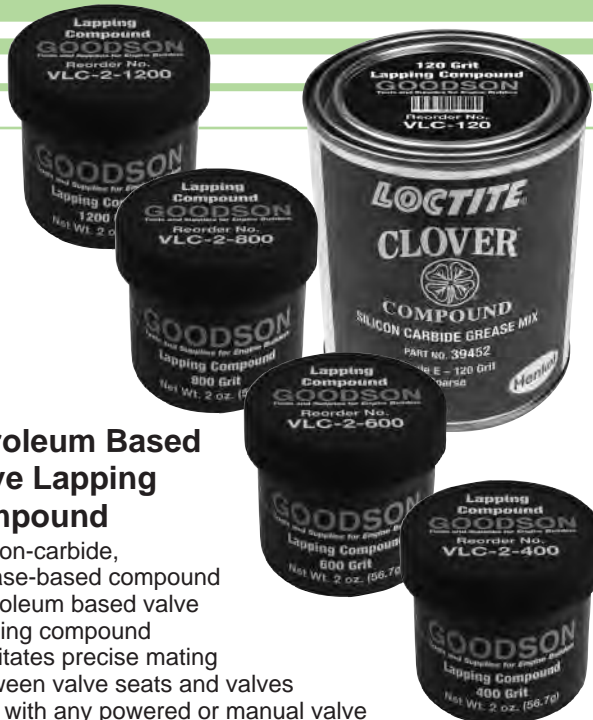

Petroleum Based Valve Lapping Compound

- Silicon-carbide, grease-based compound
- Petroleum based valve lapping compound facilitates precise mating between valve seats and valves
- Use with any powered or manual valve lapping tools • The higher the number the finer the grit

Size	Grit	Jobber	Order No.
2 oz. / 56.7g	400 Grit	\$12.99	VLC-2-400
	600 Grit	13.99	VLC-2-600
	800 Grit	18.99	VLC-2-800
	1200 Grit	19.99	VLC-2-1200
2 oz. / 56.7g ea. Combo	120 Grit & 280 Grit	31.99	VLC-4
	1 lb. / 453.6g	64.99	VLC-120
	180 Grit	64.99	VLC-180
	280 Grit	64.99	VLC-280



VSD-HD

Valve Seat Drivers For Fast Seat Installation

- Pneumatic Drivers install seats faster, easier and without galling • Driver Head ID is .75" / 19.05mm

Description	Jobber	Order No.
Manual Drivers		
.375" / 9.53mm & .385" / 9.78mm ID	\$37.99	VSD-202-G
Driver Heads (Blackened for Rust Resistance)		
1.000" to 1.125" Seats / 25.4 - 28.6mm	\$35.99	VSD-203-G
1.250" to 1.375" Seats / 31.8 - 34.9mm	35.99	VSD-204-G
1.500" to 1.625" Seats / 38.1 - 41.3mm	35.99	VSD-205-G
1.750" to 1.875" Seats / 44.5 - 47.6mm	35.99	VSD-206-G
2.000" to 2.125" Seats / 50.8 - 54.0mm	35.99	VSD-207-G
Driver Heads (Not Blackened)		
1.750" to 2.000" Seats / 44.5 - 50.8mm	\$35.99	VSD-HD
Pneumatic Drivers		
.375" / 9.53mm & .385" / 9.78mm ID	\$36.99	PSD-385
.437" / 11.10mm ID	36.99	PSD-437



Air Powered Valve Lapping Tool

- Operates on 90psi
- Includes air tool and 3 replacement cups • Air actuated ... no electricity needed • Cups also sold separately
- Air supply pressure: 89 psi
- Sound pressure: 77dB
- Sound power: 88 dB
- Hand/arm weighted vibration: 5.43 m/s²
- Use a light touch when operating - no pressure required!



Replacement Cups Also Available

Description	Cup ID	Jobber	Order No.
Air Powered Valve Lapping Tool		\$449.99	AVLP-300
Replacement Cups	21mm / 0.827" dia.	.230"	10.99 AVLP-301
	33mm / 1.299" dia.	.380"	10.99 AVLP-302
	38mm / 1.496" dia.	.380"	10.99 AVLP-303

Powered Lapping Tool

- Change rotary action into an effective oscillating motion
- Drive with a power drill
- Makes lapping faster and easier
- Includes 2 cup sizes



Description	Cup ID	Jobber	Order No.
Complete Tool		\$244.99	VLP-100
Replacement Cups	22.2mm / 0.875" dia.	.460"	12.99 VLP-10
	25.4mm / 1.000" dia.	.460"	13.99 VLP-20



Minnesota Fast Freeze



- Instantly chills seats & guides to -50°F (-45.5°C) • Creates interference fit with heated aluminum heads • Finish seat and guide work faster than ever • 10 oz. Aerosol*
- Use on tight bushings, pins, shafts, etc.
- Order No. **MFF-8**
- Jobber 1+ \$38.99 ea., Jobber 6+ \$35.09 ea.

Order 6 or more to Save 10% off Jobber

*Hazardous Goods Fees Apply When Shipped by Air

CYLINDER HEAD REBUILDING
CLEANING, ASSEMBLY & SAFETY
SHORT BLOCK REBUILDING
FLYWHEEL GRINDING
CRANKSHAFT/ TOOLS & SUPPLIES
MISCELLANEOUS
BRAKE SERVICE TOOLING
MEASURING TOOLS
V-TWIN & METRIC HARD PARTS

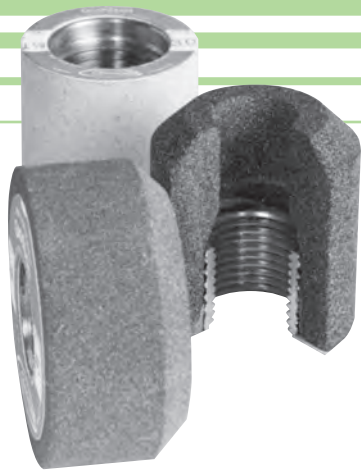

Goodson seat wheels are built to grind accurately & outlast the competition

- Brass bushings resist galling or seizing to the holder
- Heat-cured, permanent epoxy bonding prevents loose bushings
- Bushings are set deep to expose the most abrasive for long life
- Each wheel is trued and checked to assure accurate, vibration-free grinding
- **Custom sizes and angles are available in-house – Call for more information**

**GP**

General Purpose
Removes material from cast-iron seats or inserts.

**CB**

Cool Blue
Pure Aluminum-Oxide stone. Superior general purpose stone for high performance Beryllium seats. Very sharp.

**S**

Stellite
Specially formulated to grind Stellite and other types of hardened seat.

**F**

Finish
Final polishing stone gives an ideal final finish with minimal stock removal. Removes chatter marks.

**NC**

Nickel Chrome
For aluminum heads with chrom-alloy seat inserts. Soft abrasive stone to grind hard seats. Speckled.

**R**

Ruby
The original Black & Decker composition, general purpose stone.



Order 10 or more Valve Seat Wheels (any combination, pages 20 & 22) and SAVE 10% off jobber

Colors may vary due to manufacturing processes

KW

Fits Kwik-Way 13/16" x 13 thread

Size			General Purpose (GP) 90 Grit			Cool Blue (CB) 80 Grit		Finishing (F) 150 Grit		Stellite (S) 90 Grit	
Inch	mm	Jobber	00°	30°	45°	00°	45°	30°	45°	00°	45°
1 1/4"	32	\$13.99	KW-1000-GP	KW-1030-GP	KW-1045-GP	KW-1000-CB	KW-1045-CB	-----	KW-1045-F	KW-1000-S	KW-1045-S
1 1/8"	33	13.99	KW-1000A-GP	-----	KW-1045A-GP	KW-1000A-CB	KW-1045A-CB	-----	-----	-----	-----
1 3/8"	35	13.99	KW-1100-GP	KW-1130-GP	KW-1145-GP	KW-1100-CB	KW-1145-CB	KW-1130-F	KW-1145-F	KW-1100-S	KW-1145-S
1 1/8"	36	13.99	KW-1100A-GP	-----	KW-1145A-GP	KW-1100A-CB	KW-1145A-CB	-----	KW-1145A-F	KW-1100A-S	KW-1145A-S
1 1/2"	38	13.99	KW-1200-GP	KW-1230-GP	KW-1245-GP	KW-1200-CB	KW-1245-CB	KW-1230-F	KW-1245-F	KW-1200-S	KW-1245-S
1 1/8"	39	13.99	KW-1200A-GP	-----	KW-1245A-GP	-----	KW-1245A-CB	-----	KW-1245A-F	KW-1200A-S	KW-1245A-S
1 5/8"	41	13.99	KW-1300-GP	KW-1330-GP	KW-1345-GP	KW-1300-CB	KW-1345-CB	KW-1330-F	KW-1345-F	KW-1300-S	KW-1345-S
1 1/8"	43	13.99	KW-1300A-GP	-----	KW-1345A-GP	KW-1300A-CB	KW-1345A-CB	-----	KW-1345A-F	KW-1300A-S	KW-1345A-S
1 3/4"	44	14.49	KW-1400-GP	KW-1430-GP	KW-1445-GP	KW-1400-CB	KW-1445-CB	KW-1430-F	KW-1445-F	KW-1400-S	KW-1445-S
1 7/8"	47	14.49	KW-1500-GP	KW-1530-GP	KW-1545-GP	KW-1500-CB	KW-1545-CB	KW-1530-F	KW-1545-F	KW-1500-S	KW-1545-S
2"	51	15.49	KW-1600-GP	KW-1630-GP	KW-1645-GP	KW-1600-CB	KW-1645-CB	KW-1630-F	KW-1645-F	KW-1600-S	KW-1645-S
2 1/8"	54	15.49	KW-1700-GP	KW-1730-GP	KW-1745-GP	KW-1700-CB	KW-1745-CB	KW-1730-F	KW-1745-F	KW-1700-S	KW-1745-S
2 1/4"	57	15.49	KW-1800-GP	KW-1830-GP	KW-1845-GP	KW-1800-CB	KW-1845-CB	-----	KW-1845-F	KW-1800-S	KW-1845-S
2 3/8"	60	15.49	KW-1900-GP	KW-1930-GP	KW-1945-GP	KW-1900-CB	KW-1945-CB	-----	-----	-----	-----

Size			Nickel Chrome (NC) 60 Grit		Ruby (R) 80 Grit		
Inch	mm	Jobber	00°	45°	Jobber	00°	45°
1 1/4"	32	14.99	KW-1000-NC	KW-1045-NC	14.99	KW-1000-R	KW-1045-R
1 3/8"	35	14.99	KW-1100-NC	KW-1145-NC	14.99	KW-1100-R	KW-1145-R
1 1/8"	36	14.99	KW-1100A-NC	KW-1145A-NC	-----	-----	-----
1 1/2"	38	14.99	KW-1200-NC	KW-1245-NC	14.99	KW-1200-R	KW-1245-R
1 1/8"	39	14.99	KW-1200A-NC	KW-1245A-NC	-----	-----	-----
1 5/8"	41	14.99	KW-1300-NC	KW-1345-NC	14.99	KW-1300-R	KW-1345-R
1 1/8"	43	14.99	KW-1300A-NC	KW-1345A-NC	-----	-----	-----
1 3/4"	44	14.99	KW-1400-NC	KW-1445-NC	14.99	KW-1400-R	KW-1445-R
1 7/8"	47	14.99	KW-1500-NC	KW-1545-NC	14.99	KW-1500-R	KW-1545-R
2"	51	14.99	KW-1600-NC	KW-1645-NC	15.99	KW-1600-R	KW-1645-R
2 1/8"	54	15.99	KW-1700-NC	KW-1745-NC	-----	-----	-----
2 1/4"	57	15.99	KW-1800-NC	KW-1845-NC	-----	-----	-----
2 3/8"	60	15.99	KW-1900-NC	KW-1945-NC	-----	-----	-----



Keep your stones grinding at their best with a Seat Wheel Dressing Stand!

See Page 26 for details

Ordering is easy!

- 1 - Find the diameter (valve head diameter + 1/16" to 1/8").
- 2 - Find the angle you need (you can modify angles with our Valve Seat Stone Dresser, page 26).
- 3 - Select the abrasive to match your job.

tech tips
from the techxperts™



Hex Drive Seat Grinding Kit includes everything listed below. Everything comes packed in a handy storage case.

Valve Seat Grinding Sets

Order the set as-is or modify a set to meet your specific needs. Set contents include:

Description	OE Number	Jobber	Order No.	Includes		
45° Hex Drive Motor Seat Grinding Set (110V, 50/60 Hz)		\$3999.99	SGH-110-KIT	▼		
45° Hex Drive Motor Seat Grinding Set (220V, 50/60Hz)		4099.99	SGH-220-KIT	▼		
Hex Drive Seat Grinder - 45° 110V, 50/60Hz	031-3100-20	1499.99	031-3100-20	1		
Hex Drive Seat Grinder - 45° 220V, 50/60Hz	031-3100-27	1499.99	031-3100-27	1		
Universal Wheel Dresser w/G-13P Diamond		699.99	SWD-UNI	1 1		
Replacement Dressing Stand Diamond		94.99	G-13P	1 1		
Dressing Stand Pilot with .437" Top	031-1102-89	159.99	031-1102-89	1 1		
Stone Holder - 13/16" x 13 Thread w/Plunger	031-0300-30	399.99	031-0300-30	2 2		
Heavy Duty Plastic Case (21 ⁵ / ₁₆ " x 12 ¹ / ₂ " x 13 ¹ / ₂ ")	001-1000-25	51.99	SG-CASE	1 1		
Seat Stone Removal Tool		26.99	KW-SRT	1 1		
Leather Vibration Reducer (3 Pc.)		12.99	KHW-3	1 1		
.437" Top Pilots Dia./mm						
.2755" / 7.00mm	030-0237-30	\$59.99	P-5275K	1 1		
.2763" / 7.02mm	030-0237-49	59.99	P-5276K	1 1		
.2765" / 7.05mm	030-0237-40	59.99	P-5277K	1 1		
.3125" / 7.93mm	030-0239-35	59.99	P-5312K	1 1		
.3135" / 7.96mm	030-0239-51	59.99	P-5313K	1 1		
.3145" / 7.98mm	030-0239-78	59.99	P-5314K	1 1		
.3150" / 8.00mm	030-0239-94	59.99	P-5315K	1 1		
.3437" / 8.72mm	030-0242-73	59.99	P-5343K	1 1		
.3440" / 8.74mm	030-0243-03	59.99	P-5344K	1 1		
.3457" / 8.78mm	030-0243-11	59.99	P-5345K	1 1		
.3730" / 9.47mm	030-0247-45	59.99	P-5373K	1 1		
.3750" / 9.52mm	030-0247-70	59.99	P-5375K	1 1		
General Purpose Valve Seat Grinding Stones (3/16"x13)	30°			45°		
1.375" / 35mm	\$13.99	KW-1130-GP	1 1	\$13.99	KW-1145-GP	1 1
1.500" / 38mm	13.99	KW-1230-GP	1 1	13.99	KW-1245-GP	1 1
1.615" / 41mm	13.99	KW-1330-GP	1 1	13.99	KW-1345-GP	1 1
1.750" / 44mm	14.49	KW-1430-GP	1 1	14.49	KW-1445-GP	1 1
1.785" / 47mm	14.49	KW-1530-GP	1 1	14.49	KW-1545-GP	1 1
2.000" / 51mm	15.49	KW-1630-GP	1 1	15.49	KW-1645-GP	1 1
2.125" / 54mm	15.49	KW-1730-GP	1 1	15.49	KW-1745-GP	1 1
Finishing Valve Seat Grinding Stones (3/16"x13)	30°			45°		
1.375" / 35mm	\$13.99	KW-1130-F	1 1	\$13.99	KW-1145-F	1 1
1.500" / 38mm	13.99	KW-1230-F	1 1	13.99	KW-1245-F	1 1
1.625" / 41mm	13.99	KW-1330-F	1 1	13.99	KW-1345-F	1 1
1.750" / 44mm	14.49	KW-1430-F	1 1	14.49	KW-1445-F	1 1
1.785" / 47mm	14.49	KW-1530-F	1 1	14.49	KW-1545-F	1 1
2.000" / 51mm	15.49	KW-1630-F	1 1	15.49	KW-1645-F	1 1
2.125" / 54mm	15.49	KW-1730-F	1 1	15.49	KW-1745-F	1 1

made in america
KWIK-WAY
 Seat Grinding Equipment & Supplies
GOODSON
 Tools and Supplies for Engine Builders



45° Kwik-Way Hex Drive (SGH) Electric Motor Unit
 1/2"-20 Thread

- Heavy duty electric motor
- 11,500 RPM • Weighs 9 lbs.
- 3/5 HP, 7.5 Amps

Description	Jobber	Order No.
110V, 50/60Hz	\$1499.99	031-3100-20
220V, 50/60Hz	1499.99	031-3100-27
Nose Assembly	809.99	031-3105-12
Hex Drive Assembly	80.99	031-3112-17
Replacement Leather Pad	5.49	031-1009-41
2 Pc. Brush Set	32.99	003-0072-43
Trigger Switch	43.99	000-1201-20

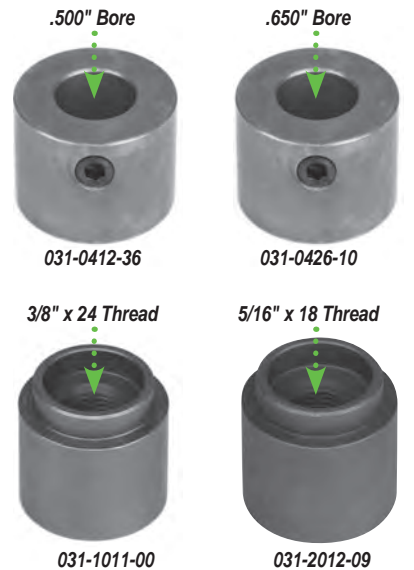

Hex Drive Replacement Adaptors
 • Adapt your Seat Grinder Motor to fit various Kwik-Way Seat Grinders

Description	Jobber	Order No.
.500" Bore	\$79.99	031-0412-36
Fit SGA Motor Units with Serial No. 0 to 2000		
.650" Bore	69.99	031-0426-10
Fit SGA Motor Units with Serial No. 4000 & up		
3/8" x 24 Thread	71.99	031-1011-00
Fit SGAll Hex Motor Units		
5/16" x 18" Thread	61.99	031-2012-09
Fit SSG Hex Motor Units		



"If you need a custom angle or size in a Valve Seat Stone, Goodson can do it. We grind seat stones in-house to standard and custom dimensions. Give Goodson a call today."

- Tim, Goodson Production - 7 years of service

SX

Fits Sioux™, KO Lee, US, Thor, Skil, Winona 11/16"x16 thread

Order 10 or more Valve Seat Wheels (any combination) and save 10% off jobber

Colors may vary due to manufacturing processes



CYLINDER HEAD
REBUILDING

CLEANING,
ASSEMBLY & SAFETY

SHORT BLOCK
REBUILDING

CRANKSHAFT/
FLYWHEEL GRINDING

MISCELLANEOUS
TOOLS & SUPPLIES

BRAKE SERVICE
TOOLING

MEASURING
TOOLS

V-TWIN & METRIC
HARD PARTS

Size Inch	mm	Jobber	General Purpose (GP) 70 Grit				Cool Blue (CB) 80 Grit			Ruby 80 Grit		
			00°	30°	45°	60°	00°	45°	Jobber	00°	45°	
7/8"	22									\$22.99	SX-500-R	SX-545-R
15/16"	24									22.99	SX-600-R	SX-645-R
1"	25									22.99	SX-700-R	SX-745-R
1 1/16"	27									22.99	SX-800-R	SX-845-R
1 1/8"	28	\$19.99	SX-900-GP	SX-930-GP	SX-945-GP					22.99	SX-900-R	SX-945-R
1 3/16"	30	19.99	SX-900A-GP		SX-945A-GP							
1 1/4"	32	13.99	SX-1000-GP	SX-1030-GP	SX-1045-GP	SX-1060-GP	\$13.99	SX-1000-CB	SX-1045-CB	13.99	SX-1000-R	SX-1045-R
1 5/16"	33	13.99	SX-1000A-GP		SX-1045A-GP		13.99	SX-1000A-CB	SX-1045A-CB			
1 3/8"	35	13.99	SX-1100-GP	SX-1130-GP	SX-1145-GP	SX-1160-GP	13.99	SX-1100-CB	SX-1145-CB	13.99	SX-1100-R	SX-1145-R
1 1/2"	36	13.99	SX-1100A-GP		SX-1145A-GP		13.99	SX-1100A-CB	SX-1145A-CB			
1 1/2"	38	13.99	SX-1200-GP	SX-1230-GP	SX-1245-GP	SX-1260-GP	13.99	SX-1200-CB	SX-1245-CB	13.99	SX-1200-R	SX-1245-R
1 5/8"	39	13.99	SX-1200A-GP		SX-1245A-GP		13.99	SX-1200A-CB	SX-1245A-CB			
1 5/8"	41	13.99	SX-1300-GP	SX-1330-GP	SX-1345-GP	SX-1360-GP	13.99	SX-1300-CB	SX-1345-CB	13.99	SX-1300-R	SX-1345-R
1 11/16"	43	13.99	SX-1300A-GP		SX-1345A-GP		13.99	SX-1300A-CB	SX-1345A-CB			
1 3/4"	44	13.99	SX-1400-GP	SX-1430-GP	SX-1445-GP	SX-1460-GP	13.99	SX-1400-CB	SX-1445-CB	13.99	SX-1400-R	SX-1445-R
1 7/8"	47	13.99	SX-1500-GP	SX-1530-GP	SX-1545-GP	SX-1560-GP	13.99	SX-1500-CB	SX-1545-CB	13.99	SX-1500-R	SX-1545-R
2"	51	13.99	SX-1600-GP	SX-1630-GP	SX-1645-GP	SX-1660-GP	13.99	SX-1600-CB	SX-1645-CB	13.99	SX-1600-R	SX-1645-R
2 1/8"	54	13.99	SX-1700-GP	SX-1730-GP	SX-1745-GP		13.99	SX-1700-CB	SX-1745-CB	13.99	SX-1700-R	SX-1745-R
2 1/4"	57	13.99	SX-1800-GP	SX-1830-GP	SX-1845-GP	SX-1860-GP	13.99	SX-1800-CB	SX-1845-CB	13.99	SX-1800-R	SX-1845-R
2 3/8"	60	13.99	SX-1900-GP	SX-1930-GP	SX-1945-GP	SX-1960-GP	13.99	SX-1900-CB	SX-1945-CB	13.99	SX-1900-R	SX-1945-R
2 1/2"	63	13.99	SX-2000-GP	SX-2030-GP	SX-2045-GP		13.99	SX-2000-CB	SX-2045-CB	13.99	SX-2000-R	SX-2045-R
2 5/8"	66	13.99	SX-2100-GP	SX-2130-GP	SX-2145-GP		13.99	SX-2100-CB	SX-2145-CB			

Size Inch	mm	Jobber	Stellite (S) 100 Grit			Finishing (F) 150 Grit			Nickel Chrome 60 Grit				
			00°	30°	45°	Jobber	00°	30°	45°	Jobber	00°	30°	45°
1/2"	12.7								\$23.99	SX-200-NC			
9/16"	14.3								23.99	SX-200A-NC			
5/8"	15.9								23.99	SX-300-NC			
1 1/16"	17.4								23.99	SX-300A-NC			
3/4"	19.1								23.99	SX-400-NC			
13/16"	20.6								22.99	SX-400A-NC			
7/8"	22					\$23.99	SX-500-F	SX-545-F	22.99	SX-500-NC		SX-545-NC	
15/16"	24					23.99	SX-600-F	SX-645-F	22.99	SX-600-NC		SX-645-NC	
1"	25					23.99	SX-700-F	SX-745-F	22.99	SX-700-NC		SX-745-NC	
1 1/16"	27					23.99	SX-800-F	SX-845-F	22.99	SX-800-NC		SX-845-NC	
1 1/8"	28	\$19.99	SX-900-S	SX-930-S	SX-945-S	19.99	SX-900-F	SX-930-F	SX-945-F	19.99	SX-900-NC	SX-930-NC	SX-945-NC
1 3/16"	30	19.99	SX-900A-S		SX-945A-S	19.99	SX-900A-F		SX-945A-F	19.99	SX-900A-NC		SX-945A-NC
1 1/4"	32	12.99	SX-1000-S	SX-1030-S	SX-1045-S	13.99	SX-1000-F	SX-1030-F	SX-1045-F	13.99	SX-1000-NC	SX-1030-NC	SX-1045-NC
1 5/16"	33	12.99	SX-1000A-S		SX-1045A-S	13.99	SX-1000A-F		SX-1045A-F	13.99	SX-1000A-NC		SX-1045A-NC
1 3/8"	35	12.99	SX-1100-S	SX-1130-S	SX-1145-S	13.99	SX-1100-F	SX-1130-F	SX-1145-F	13.99	SX-1100-NC	SX-1130-NC	SX-1145-NC
1 1/2"	36	12.99	SX-1100A-S		SX-1145A-S	13.99	SX-1100A-F		SX-1145A-F	13.99	SX-1100A-NC		SX-1145A-NC
1 1/2"	38	12.99	SX-1200-S	SX-1230-S	SX-1245-S	11.99	SX-1200-F	SX-1230-F	SX-1245-F	13.99	SX-1200-NC	SX-1230-NC	SX-1245-NC
1 5/8"	39	12.99	SX-1200A-S		SX-1245A-S	11.99	SX-1200A-F		SX-1245A-F	13.99	SX-1200A-NC		SX-1245A-NC
1 5/8"	41	12.99	SX-1300-S	SX-1330-S	SX-1345-S	11.99	SX-1300-F	SX-1330-F	SX-1345-F	13.99	SX-1300-NC	SX-1330-NC	SX-1345-NC
1 11/16"	43	12.99	SX-1300A-S		SX-1345A-S	11.99	SX-1300A-F		SX-1345A-F	13.99	SX-1300A-NC		SX-1345A-NC
1 3/4"	44	12.99	SX-1400-S	SX-1430-S	SX-1445-S	12.99	SX-1400-F	SX-1430-F	SX-1445-F	13.99	SX-1400-NC	SX-1430-NC	SX-1445-NC
1 7/8"	47	12.99	SX-1500-S	SX-1530-S	SX-1545-S	12.99	SX-1500-F	SX-1530-F	SX-1545-F	13.99	SX-1500-NC	SX-1530-NC	SX-1545-NC
2"	51	12.99	SX-1600-S	SX-1630-S	SX-1645-S	12.99	SX-1600-F	SX-1630-F	SX-1645-F	13.99	SX-1600-NC	SX-1630-NC	SX-1645-NC
2 1/8"	54	12.99	SX-1700-S	SX-1730-S	SX-1745-S	14.29	SX-1700-F	SX-1730-F	SX-1745-F	13.99	SX-1700-NC	SX-1730-NC	SX-1745-NC
2 1/4"	57	12.99	SX-1800-S	SX-1830-S	SX-1845-S	14.29	SX-1800-F	SX-1830-F	SX-1845-F	13.99	SX-1800-NC	SX-1830-NC	SX-1845-NC
2 3/8"	60	12.99	SX-1900-S	SX-1930-S	SX-1945-S	17.99	SX-1900-F	SX-1930-F	SX-1945-F	13.99	SX-1900-NC	SX-1930-NC	SX-1945-NC
2 1/2"	63	12.99	SX-2000-S	SX-2030-S	SX-2045-S	17.99	SX-2000-F	SX-2030-F	SX-2045-F	13.99	SX-2000-NC	SX-2030-NC	SX-2045-NC
2 5/8"	66									15.99	SX-2100-NC	SX-2130-NC	SX-2145-NC

All Valve Seat Wheels are guaranteed against manufacturing defects for 1 year from original purchase date



2 Angle Valve Seat Wheels

- Use with SX-HOLDER & SX-78 adaptor (page 24)
- 30° one side, 45° on the other side

General Purpose		
Inch	mm	Order No.
3"	76.2	SXL-2345-GP
3 1/4"	82.5	SXL-2445-GP
3 1/2"	88.9	SXL-2545-GP
3 3/4"	92.3	SXL-2645-GP
4"	101.6	SXL-2745-GP
Jobber		\$24.99

SX-HOLDER



SX-78



KWIK-WAY
 Seat Grinding Equipment & Supplies
MFG BY

GOODSON

Tools and Supplies for Engine Builders



45° Sioux-Style (SGK) Star Drive Electric Motor Unit

- Heavy duty electric motor
- 11,500 RPM
- Weighs 9 lbs.
- 3/5 HP • 7.5 Amps

Description	Jobber	Order No.
110V, 50/60Hz	\$1499.99	031-3100-21
220V, 50/60Hz	1599.99	031-3100-28
Nose Assembly	809.99	031-3105-12
2 Pc. Brush Set	32.99	003-0072-43
Trigger Switch	43.99	000-1201-20

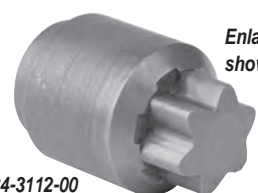

Enlarged to show detail

034-3112-00

Replacement Drive Assemblies

- 1/2" x 20 thread
- Easy to install
- Always keep one on hand for emergencies

Description	Jobber	Order No.
Star Drive (SGH)	\$80.99	034-3112-00

Sioux-Style Valve Seat Grinding Kits

These kits include everything you need to get started in seat grinding. Choose between kits including 110V and 220V Star Drive Electric Grinders. After that, everything else in the kit is identical.

We started with the most common sizes of pilots and valve seat stones, but you can customize one of these kits to meet your specific needs. Call 1-800-533-8010 for additional information.

Description	OE Number	Jobber	Order No.	Includes		
45° Star Drive Motor Seat Grinding Set (110V, 50/60 Hz)		\$3499.99	SGK-110-KIT	▼		
45° Star Drive Motor Seat Grinding Set (220V, 50/60Hz)		3599.99	SGK-220-KIT	▼		
Star Drive Seat Grinder - 45° 110V, 50/60 Hz	031-3100-21	1499.99	031-3100-21	1		
Star Drive Seat Grinder - 45° 220V, 50/60 Hz	031-3100-28	1599.99	031-3100-28	1		
Universal Seat Wheel Dresser w/G-13P Diamond	-----	699.99	SWD-UNI	1 1		
Replacement Dressing Diamond	-----	94.99	G-13P			
Dressing Stand Pilot	031-0202-55	159.99	031-0202-55	1 1		
Stone Holder - 1/8" x 16 Thread	1702	197.99	SX-HOLDER	2 2		
Heavy Duty Plastic Storage Box (21 1/16" x 12 1/2" x 13 1/2")	001-1000-25	51.99	SG-CASE	1 1		
Seat Stone Removal Tool	-----	26.99	SX-SRT	1 1		
Bounce Spring Set (3 Pc.)	-----	19.99	BSS-100	1 1		
Leather Vibration Reducer (3 Pc.)	-----	12.99	SHW-3	1 1		
.385" Top Pilots	Dia./mm					
	.2755" / 7.00mm	\$49.99	P-5275S	1 1		
	.2763" / 7.02mm	49.99	P-5277S	1 1		
	.2779" / 7.05mm	49.99	P-5278S	1 1		
	.3125" / 7.94mm	49.99	P-5312S	1 1		
	.3130" / 7.95mm	49.99	P-5313S	1 1		
	.3141" / 7.98mm	49.99	P-5314S	1 1		
	.3149" / 8.00mm	49.99	P-5315S	1 1		
	.3430" / 8.71mm	49.99	P-5343S	1 1		
	.3440" / 8.73mm	49.99	P-5344S	1 1		
	.3450" / 8.76mm	49.99	P-5345S	1 1		
	.3750" / 9.53mm	49.99	P-5375S	1 1		
	.3760" / 9.55mm	49.99	P-5376S	1 1		
General Purpose Seat Grinding Stones (1/16"x16)	30°			45°		
1.375" / 35mm	\$13.99	SX-1130-GP	1 1	\$13.99	SX-1145-GP	1 1
1.500" / 38mm	13.99	SX-1230-GP	1 1	13.99	SX-1245-GP	1 1
1.625" / 41mm	13.99	SX-1330-GP	1 1	13.99	SX-1345-GP	1 1
1.750" / 44mm	13.99	SX-1430-GP	1 1	13.99	SX-1445-GP	1 1
1.785" / 47mm	13.99	SX-1530-GP	1 1	13.99	SX-1545-GP	1 1
2.000" / 51mm	13.99	SX-1630-GP	1 1	13.99	SX-1645-GP	1 1
2.125" / 54mm	13.99	SX-1730-GP	1 1	13.99	SX-1745-GP	1 1
Finishing Valve Seat Grinding Stones (1/16"x16)	30°			45°		
1.375" / 35mm	\$13.99	SX-1130-F	1 1	\$13.99	SX-1145-F	1 1
1.500" / 38mm	11.99	SX-1230-F	1 1	11.99	SX-1245-F	1 1
1.625" / 41mm	11.99	SX-1330-F	1 1	11.99	SX-1345-F	1 1
1.750" / 44mm	12.99	SX-1430-F	1 1	12.99	SX-1445-F	1 1
1.785" / 47mm	12.99	SX-1530-F	1 1	12.99	SX-1545-F	1 1
2.000" / 51mm	12.99	SX-1630-F	1 1	12.99	SX-1645-F	1 1
2.125" / 54mm	14.29	SX-1730-F	1 1	14.29	SX-1745-F	1 1

CYLINDER HEAD REBUILDING
 CLEANING, ASSEMBLY & SAFETY
 SHORT BLOCK REBUILDING
 FLYWHEEL GRINDING
 CRANKSHAFT/ FLYWHEEL GRINDING
 MISCELLANEOUS TOOLS & SUPPLIES
 TOOLS
 MEASURING TOOLS
 BRAKE SERVICE TOOLING
 V-TWIN & METRIC HARD PARTS

Seat Stone Holders, Adaptors, Etc.

Valve Seat Stone Holders & Accessories

- Ball-bearing stone holders • Ideal replacements for worn holders • Save time by having several holders set up with commonly used sizes, compositions or angles of seat stones

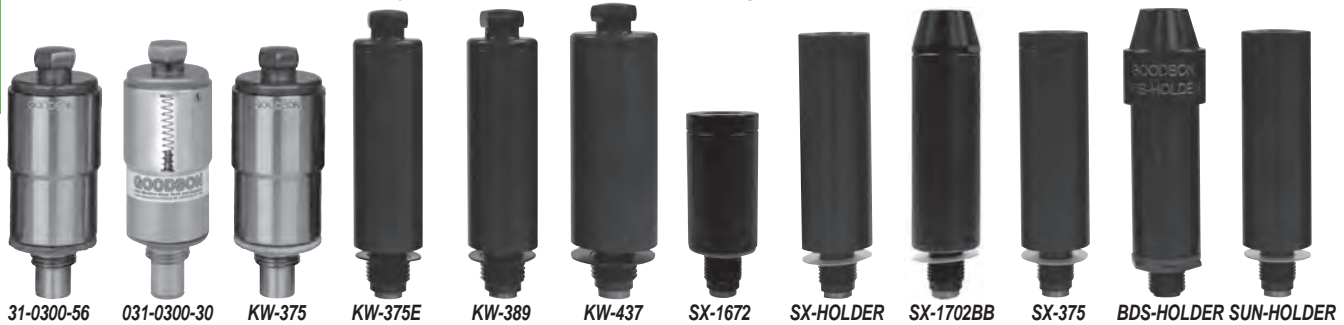

Rebuildable $\frac{13}{16}$ "x13 Thread Hex Drive Kwik-Way Stone Holders		
Description	Jobber	Order No.
Fits .437" Top Pilot Hex-Drive w/o Spring Plunger	\$379.99	031-0300-56
Fits .437" Top Pilot Hex-Drive with Spring Plunger	399.99	031-0300-30
Fits .375" Top Pilot Hex Drive w/o Spring Plunger	394.99	KW-375
Non-Rebuildable Hex Drive Stone Holders		
Fits .375" Top Pilot $\frac{13}{16}$ "x13 thread	\$227.99	KW-375E
Fits .389" Top Pilot $\frac{13}{16}$ "x13 thread	227.99	KW-389
Fits .437" Top Pilot $\frac{13}{16}$ "x13 thread	244.99	KW-437

.385" Pilot, $\frac{11}{16}$ "x16 Thread Sioux-Style Stone Holders				
Description	OAL	OE #	Jobber	Order No.
Short Body (Star)	3 1/2"	1672	\$154.99	SX-1672
Star Drive	4 3/4"	$\frac{11}{16}$ "x16 thread	197.99	SX-HOLDER
$\frac{5}{8}$ " Hex Drive	5 3/16"	1702BB	199.99	SX-1702BB
.375" Pilot Stone Holders, $\frac{11}{16}$ " x 16 Thread				
Star Drive	4 3/4"	$\frac{11}{16}$ "x16 thread	\$229.99	SX-375
Black & Decker Style $\frac{9}{16}$ "x16 Thread BD-HOLDER			214.99	BDS-HOLDER
Includes BD-60 adaptor to convert $\frac{9}{16}$ "x16 to $\frac{11}{16}$ "x16 Sioux-style stones				
.389" Pilot Stone Holders, $\frac{11}{16}$ " x 16 Thread				
Sioux-Style (Star)	4 3/4"	1702	\$229.99	SUN-HOLDER



Accessories	Jobber	Order No.
Stabilizer Assembly with Bronze Bushing	\$59.99	031-0126-60
Heavy-Duty Twisted Cable Steel Coupling	91.99	031-0304-10
Replacement Hex Drive Body Cap	80.99	031-0302-95
Replacement Spring Plunger Assembly	10.99	031-0313-97
Leather Vibration Reducer (3 pc.) For KW-Holders	12.99	KHW-3
Valve Seat Stone Removal Tool	26.99	KW-SRT

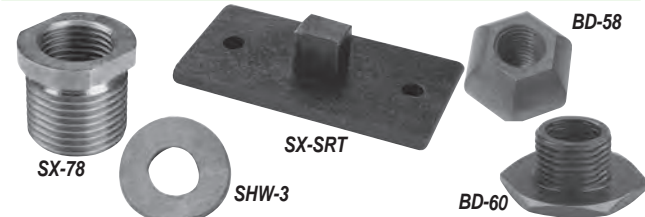

Accessories	Jobber	Order No.
Sioux-Style Conversion Bushings $\frac{11}{16}$ "x16 to $\frac{7}{8}$ "x14	\$10.49	SX-78
Leather Vibration Reducer (3 pc.) For SX-Holders	12.99	SHW-3
Standard Bounce Spring Set (3pc.)	19.99	BSS-100
Valve Seat Stone Removal Tool	26.99	SX-SRT
Black & Decker $\frac{5}{8}$ " Hexball $\frac{9}{16}$ "x24 thread	59.99	BD-58
$\frac{9}{16}$ "-16 to $\frac{11}{16}$ "-16 Adaptor for Sioux Style	10.49	BD-60



Rebuild Kits
For Hex Drive Stone Holder without Spring Plunger Includes 2 Bearings, Bearing Sleeve, Bearing Lock Nut, Sleeve Key, Hex Cap & Garter Spring
 Jobber \$209.99 Order No. **034-0002-00**



For Hex Drive Stone Holder with Spring Plunger
 Includes 2 Bearings, Bearing Sleeve, Bearing Lock Nut, Sleeve Key, Hex Cap & Spring Plunger
 Jobber \$214.99 Order No. **034-0002-15**



For Flex Drive Stone Holder
 Includes 2 Bearings, Bearing Sleeve, Heavy Duty Flex Coupling, Inner Sleeve Key & Set Screw
 Jobber \$299.99 Order No. **034-0003-25**
 Rebuild kit components are not available individually



Description	Jobber	Order No.
$\frac{13}{16}$ "-13 (KW) Threaded Stones to $\frac{11}{16}$ "-16 Threaded Holders (Sioux™, KO Lee)	\$64.99	031-0390-02
$\frac{13}{16}$ "-13 (KW) Threaded Stones to $\frac{9}{16}$ "-16 Threaded Holders (Black & Decker)	64.99	031-0391-00
$\frac{13}{16}$ "-13 (KW) Threaded Stones to $\frac{21}{32}$ "-18 Threaded Holders (Kwik-Way)	64.99	031-0393-04

Air Drive Adaptors

- $\frac{1}{4}$ " shank
- Adaptors available for a variety of stone holders
- Use with bounce springs (page 26) for best results

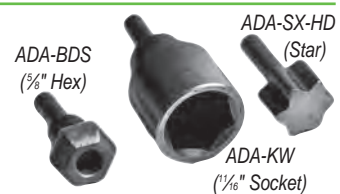

Description	Jobber	Order No.	
Hexball Driver	$\frac{5}{8}$ " SAE thread	\$79.99	ADA-BDS
Kwik-Way Drive Adaptor	$\frac{7}{8}$ " x 20 thread	79.99	ADA-KW
Sioux-Style Drive Adaptor	Welded style adaptor	89.99	ADA-SX-HD



Aircraft Extended Nose Seat Grinding Motor

- Heavy Duty Electric Motor
- Extended drive unit allows easy access to aircraft engines including Lycoming and Continental
- Spline drive for use with Sioux-Style stone holders
- Available in 110V or 220V models
- 11,500 RPM (free speed) / 6982 RPM under load
- Weighs 12 lbs. • 3/5 HP, 7.5 AMP motor

Description	Jobber	Order No.
110V Extended Nose Unit	\$1799.99	SGL-SL110
220V Extended Nose Unit	1899.99	SGL-SL220



Aviation Valve Seat Grinding Kits

Spline Drive Seat Grinding Kit includes everything listed below. Everything comes packed in a handy storage case. Kit includes:

Description	Jobber	Order No.	Includes
110V Aviation Valve Seat Grinding Kit	\$4859.99	AV-110-KIT	▼
220V Aviation Valve Seat Grinding Kit	4859.99	AV-220-KIT	▼
110V Extended Drive Unit	1799.99	SGL-SL110	x
220V Extended Drive Unit	1899.99	SGL-SL220	x
Heavy Duty Valve Seat Wheel Dresser	1229.99	031-1900-02	x x
Includes .375" Top Dressing Stand Pilot	159.99	031-0202-55	
Replacement Dresser Diamond	44.99	G-18	
.375" Sioux-Style Stone Holders	229.99	SX-375	2 2
Heavy Duty Plastic Storage Box	51.99	SG-CASE	x x
Stone Removal Tool	26.99	SX-SRT	x x
Leather Vibration Reducers (3 Pc.)	12.99	SHW-3	x x
Bounce Spring Set	19.99	BSS-100	x x
.375" Bushing Set	9.99	3D-DB7	x x

.375" Top High Speed Steel Tapered Pilots	Dia.	Jobber	Order No.	Includes
.343" Dia.	.343" Dia.	92.99	AP-5343	
.344" Dia.	.344" Dia.	92.99	AP-5344	
.345" Dia.	.345" Dia.	92.99	AP-5345	
.375" Dia.	.375" Dia.	92.99	AP-5375	x x
.376" Dia.	.376" Dia.	92.99	AP-5376	x x
.377" Dia.	.377" Dia.	92.99	AP-5377	
.406" Dia.	.406" Dia.	92.99	AP-5406	
.407" Dia.	.407" Dia.	92.99	AP-5407	
.408" Dia.	.408" Dia.	92.99	AP-5408	
.436" Dia.	.436" Dia.	92.99	AP-5436	
.437" Dia.	.437" Dia.	92.99	AP-5437	x x
.438" Dia.	.438" Dia.	92.99	AP-5438	x x
.439" Dia.	.439" Dia.	92.99	AP-5439	x x
.498" Dia.	.498" Dia.	92.99	AP-5498	
.499" Dia.	.499" Dia.	92.99	AP-5499	
.500" Dia.	.500" Dia.	92.99	AP-5500	x x
.501" Dia.	.501" Dia.	92.99	AP-5501	x x
.502" Dia.	.502" Dia.	92.99	AP-5502	x x

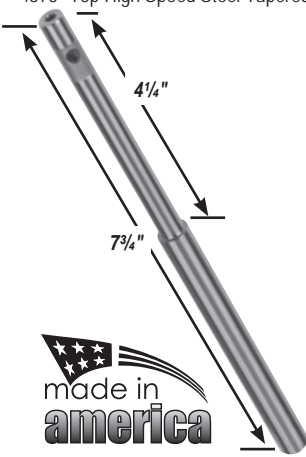

General Purpose Valve Seat Stones	Angle	Dia.	Jobber	Order No.	Includes
	30°	1 3/4" Dia.	13.99	SX-1430-GP	x x
	45°	1 3/4" Dia.	13.99	SX-1445-GP	x x
	30°	2 1/2" Dia.	13.99	SX-2030-GP	x x
	45°	2 1/2" Dia.	13.99	SX-2045-GP	x x
Cool Blue Valve Seat Stones	00°	1 3/4" Dia.	13.99	SX-1400-CB	x x
	00°	2 1/2" Dia.	13.99	SX-2000-CB	x x
Finishing Valve Seat Stones	30°	1 3/4" Dia.	12.99	SX-1430-F	x x
	45°	1 3/4" Dia.	12.99	SX-1445-F	x x
	30°	2 1/2" Dia.	17.99	SX-2030-F	x x
	45°	2 1/2" Dia.	17.99	SX-2045-F	x x



90° Angle High-Speed Air Drivers

- 2 models available - Star or hex drive
- 11,000 RPM motor • 5/8" - 11 spindle
- 1/4" air inlet • 6 CFM • Rear exhaust
- Weighs 2.25 lbs. • Measures 8.75" long
- Composite grip and trigger are designed for user comfort

Description	Jobber	Order No.
Star Drive (SGK) 5/8" - 11 spindle	\$369.99	AG-SX90
Hex Drive (SGH) 5/8" - 11 spindle	369.99	AG-KW90
Replacement Drive Adaptors (1 1/2" OAL)		
Star-Drive (SGK) Adaptor	\$107.99	SW-SX
Hex Socket (SGH) Adaptor	107.99	SW-KW



CYLINDER HEAD REBUILDING
CLEANING, ASSEMBLY & SAFETY
SHORT BLOCK REBUILDING
FLYWHEEL GRINDING
CRANKSHAFT/SCCELLANEOUS
TOOLS & SUPPLIES
BRAKE SERVICE TOOLING
MEASURING TOOLS
V-TWIN & METRIC HARD PARTS

Stones and Holders
sold separately

**Goodson
exclusive**

Universal Valve Seat Wheel Dressing Stand

- Infinitely adjustable from 0° to 90°
- Scale marked in 1° increments
- Dress stones up to 4" diameter
- Includes Premium dresser diamond & dresser pilot
- Base has pre-drilled holes for easy mounting to your bench
- Choose dresser pilot separately from chart below



Includes
Premium Dresser Pilot
Choose From
Chart Below

Description	Jobber	Order No.	Incl.
Universal Dressing Stand	\$699.99	SWD-UNI	▼
Replacement Premium Dressing Diamond	94.99	G-13P	x
Dressing Stand Riser Bushings (.250" & .875" Tall)	11.99	SK-9-10	x
Dressing Stand Riser Bushings (For .437" dresser pilots)	11.99	SK-11-12	
Replacement Parts			
Spring Detent	\$ 21.99	SWD-UNI-DET	
Arm Assembly with Spring & Plunger	259.99	SWD-UNI-ARM	

See pages 20-25 for valve seat stones, stone holders, air drivers, etc.

Heavy Duty Valve Seat Wheel Dresser

- Ball bearing mounted diamond carrier
- Adjustable in 1° increments from 0° to 90°
- Includes diamond
- Choose dressing pilot separately from list below
- Designed for maximum accuracy

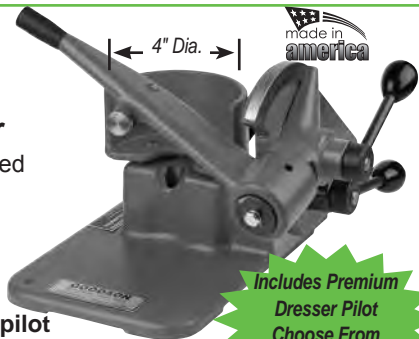

Includes Premium
Dresser Pilot
Choose From
Chart Below

Description	Jobber	Order No.
Heavy Duty Dresser	\$1229.99	031-1900-02
Replacement Torsion Spring for 031-1900-02	37.99	000-1850-78
Replacement Brass Plug	24.99	031-1917-00
Replacement Diamond Dresser	44.99	G-18

made in
america

Valve Seat Wheel Dresser Pilots for Universal & Heavy Duty Wheel Dressers

- .437" top pilots include a groove
- All pilots have .625" bottom

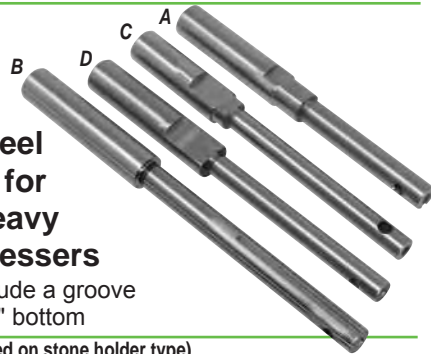

Dresser Pilots (select based on stone holder type)			
Fits Stone Holder Type	OAL	Jobber	Order No.
A .437" Hex Stone Holder	5"	\$159.99	031-1102-89
B .437" Hex or Flex Stone Holder	7"	159.99	031-0202-80
C .385" Top Stone Holder	6"	159.99	031-0202-55
D .375" Top Stone Holder	6"	159.99	031-0202-47



Seat Stone Removal Tool

Once in a while a valve seat stone will be so tight on the stone holder that it's almost impossible to get off. That's why we came up with this tool. Simply fasten it to your bench with screws or bolts (not included) or clamp it in a vise, place the holder onto the fixture and twist the stone off easily.

Description	Jobber	Order No.
Sioux-Style	\$26.99	SX-SRT
Kwik-Way Style	26.99	KW-SRT

Valve Seat Height Gauge

- Adjusts for all popular valve seat diameters • Gauge accurate to .001"
- Seat contact probe aligns on valve seat while gauge rides along the fire deck • Pilot aligns in valve guide
- Fully adjustable seat contact probe and gauge positions allow tool to fit popular seat diameters from .750" to 3.00"
- Includes Dial Indicator



Description	Fits Pilot	Jobber	Order No.
Valve Seat Height Gauge Kit	.375"	\$102.99	VSHG-375
Replacement Dial Indicator		31.99	EDI-1

tech tips

Goodson recommends using Bounce Springs with your Valve Seat Stones to prevent damage to the stone and the from the techparts™ seat. This is especially important with the very small stones.

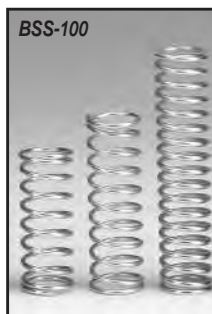

Standard Bounce Spring Set

- Includes 1 each of 3 lengths: 1" / 24.5mm, 1.50" / 38.1mm & 2" / 50.8mm
- ID = .450" / 11.4mm
- OD = .570" / 14.5mm
- Not for use with 3-D Fast Cut
- Order No. **BSS-100**
Jobber \$19.99

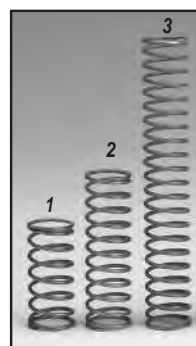

Small Diameter Bounce Springs

- ID = .406"/10.3mm
 - OD = .500"/12.7mm
- | Length / mm | Jobber | Order No. |
|--------------|--------|-----------|
| 1.10" / 27.9 | \$9.99 | BS-1 |
| 1.67" / 42.4 | 9.99 | BS-2 |
| 3.00" / 76.2 | 9.99 | BS-3 |

Valve Refacing

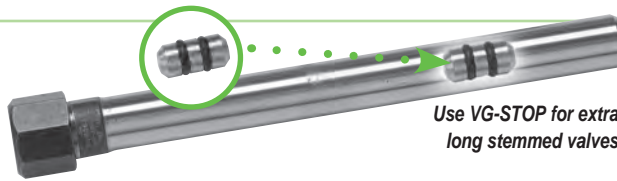

Use VG-STOP for extra long stemmed valves



Find out how to expand the capacity of your valve refacer to accept smaller valves. Scan the code at right with your smart phone or other smart device for instant access.



Adaptor for 1/2" Chucks

- For small diameter valves
- Collet cover range from 2.8mm to 6.5mm
- Hardened steel collet holder fits any machine with a 1/2" chuck
- Collet seats in retainer nut for fast, easy removal
- Internal stop adjusts, allowing you to reface an entire set of valves to identical specs quickly
- Start with the set then replace collets as needed (**collets will not work without the holder**)
- Use the Adaptor Stop to machine longer valve stems

Description	Range	Jobber	Order No.	Incl.
Full Set		\$349.99	UVRC-46	▼
Steel Collet Holder (collets MUST be used)		219.99	UVRC-46R	x
Replacement Collets	2.8 to 3.2mm (.109" to .125")	42.99	UVRC-18	
	3.0 to 3.5mm (.118" to .138")	42.99	UVRC-3.5MM	x
	3.5 to 4.0mm (.138" to .158")	42.99	UVRC-4.0MM	x
	4.0 to 4.5mm (.158" to .177")	42.99	UVRC-4.5MM	
	4.4 to 4.8mm (.172" to .1875")	42.99	UVRC-316	
	4.5 to 5.0mm (.177" to .196")	42.99	UVRC-5MM	x
	4.8 to 5.2mm (.1875" to .203")	42.99	UVRC-1364	
	5.0 to 5.5mm (.196" to .216")	42.99	UVRC-5.5MM	x
	5.5 to 6.0mm (.216" to .236")	42.99	UVRC-6.0MM	
	6.0 to 6.5mm (.236" to .256")	42.99	UVRC-6.5MM	x
Replacement Nut		53.99	UVRC-NUT	
Adaptor Stop		15.99	VG-STOP	x



Valve Stem to Valve Face Concentricity Gauge

- Accurate to .001"
- Features a rugged, positive stop – set it once and do an entire set of valves
- Use before grinding to eliminate needless cleaning & machine time
- Use after refacing to ensure stem concentricity
- Also check pilots and other small parts for concentricity
- For stems as small as 4mm
- Order No. VCG-16 Jobber \$289.99

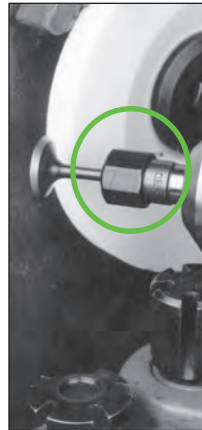

GMC-RIMAC



GMC-AG300



GMC-VST



GMC-KW

Protect Your Valuable Machines When Not In Use!

Sun-Dura® Canvas Machine Covers

- Heavy-weight, breathable black Sun-Dura® fabric won't hold in moisture
- Several sizes to fit a variety of machines • All covers will fit other machines, just match your machine's dimensions to the cover dimensions
- Covers are opaque, pictures for demonstration only

Fits Machine	Dimensions	Jobber	Order No.
Goodson Ring Filer	13"L x 7 1/2"D x 7 1/2"H	\$32.99	GMC-PRF
Rimac Spring Tester	32" Dia. x 18 1/2"H, tapers to 3" sq.	32.99	GMC-RIMAC
Goodson VST-60G Spring Tester	10"L x 14"D x 18"H	43.99	GMC-VST
Sioux 2075 Valve Refacer	35"L x 27"D x 16"H	64.99	GMC-SX
Kwik-Way SVS II Valve Refacer	35"L x 15"D x 12"H, trapezoid shape	64.99	GMC-KW
Sunnen AG-Series Precision Gauge	8"L x 8"W x 4"D	39.99	GMC-AG300

GMC-PRF









CYLINDER HEAD REBUILDING
CLEANING, ASSEMBLY & SAFETY
SHORT BLOCK REBUILDING
FLYWHEEL GRINDING
CRANKSHAFT/ FLYWHEEL GRINDING
TOOLS & SUPPLIES
MISCELLANEOUS
BRAKE SERVICE TOOLING
MEASURING TOOLS
V-TWIN & METRIC HARD PARTS

"Love your service and catalog. Our last order got here to Memphis in one day!"
 - Mike Wilkes, Memphis Motor Werks, Cordova, TN, Goodson customer since 1996

Precision made wheels = superior performance

We stock more than 40 individual valve refacer wheels, each one designed for a specific machine. Our 4" general purpose wheel for Black & Decker is different from our 4" general purpose wheel for Sioux™. We won't compromise on performance just to simplify our inventory. Your valve refacer requires a certain type of grit, grade and bond and Goodson delivers. All Goodson Valve Refacing Wheels are designed to be used with mineral based grinding oils such as VGO-10 or VGO-SD10. Goodson guarantees all valve refacing wheels against manufacturing defects for 1 year from original purchase date.

Choose from these types: **GP** = for general purpose grinding **S** = for grinding Stellite, **T** = for grinding Titanium, and **CB** = for general purpose grinding of harder materials. Stone color may vary due to manufacturing process.

To Fit	Use	Dia x Ht x Arb	Shape	Type	Color	Fits Models	OE No.	Jobber	Order No.
Black & Decker	Valve	4" x 1" x 5/8"	Offset	CB	Blue	A, B, C, LW, M, MW, N, NW, NWB	Goodson Spec	\$ 35.99	GV-146-CB
		4" x 1" x 5/8"	Offset	S	Ruby	A, B, C, LW, M, MW, N, NW, NWB	16371	37.99	GV-144
		4" x 1" x 3/8"	Offset	GP	Gray	All but 680, 682, 285, 956		36.99	GV-147
		4" x 1" x 5/8"	Offset	GP	Black	All but 680, 682, 285, 956		62.99	GV-148
		4" x 1" x 5/8"	Offset	T	Green	All but 680, 682, 285, 956	Goodson Spec	52.99	GV-150
	Stem	5" x 1" x 3/8"	Offset/20°	GP	Pink	P, PC, PCB, T, TD, TG	34131	53.99	GV-156
		4" x 1 1/8" x 1/2"	Cup	GP	Ruby	All models	20939	37.99	GV-145
Comec	Valve	215 x 35 x 76mm	Flared	GP	Gray	VR416, RV-516	7604	196.99	GV-925
		215 x 35 x 76mm	Flared	S	Brown	VR416, RV-516	Goodson Spec	194.99	GV-980
	Stem	100 x 50 x 20mm	Cup	GP	White	VR416, RV-516	7606	60.99	GV-928
IDL Sunnen®	Valve	8" x 1 1/4" x 1 1/2"	Flared	GP	White	CG-50,-80,-82, V-90, VR-7000	8230	157.99	GV-823
		8" x 1 1/4" x 1 1/2"	Flared	GP	Gray	CG-50,-80,-82, V-90, VR-7000	VR1703	203.99	GV-825
		8" x 1 1/4" x 1 1/2"	Flared	S	White	CG-50,-80,-82, V-90, VR-7000	Goodson Spec	132.99	GV-821
	Stem	8" x 1 1/4" x 1 1/2"	Flared	T	Green	CG-50,-80,-82, V-90, VR-7000	VR1704	144.99	GV-827
		8" x 1 1/4" x 1 1/2"	Flared	GP	Ruby	CG-80, CG-82, V-90, VR-7000	VR1701	119.99	GV-824
Kwik-Way	Valve	4 1/2" x 7/8" x 7/8"	Offset	GP	Black	CV, SK, KK, VC, SM, SV, XC	010-0450-10	69.99	GV-257
		4 1/2" x 7/8" x 7/8"	Offset	S	Gray	CV, SK, KK, VC, SM, SV, XC	010-0457-03	45.99	GV-259
		5" x 7/8" x 7/8"	Offset	GP	White	EVS, VS	Goodson Spec	71.99	GV-251
		5" x 7/8" x 7/8"	Offset	GP	Gray	EVS, VS	010-0509-01	66.99	GV-252
		5" x 7/8" x 7/8"	Offset	T	Green	EVS, VS	010-0508-04	139.99	GV-255
		7" x 1" x 7/8"	Offset	GP	Gray	SVS, SVS-2	010-0709-00	69.99	GV-280
		7" x 1" x 7/8"	Offset	CB	Blue	SVS, SVS-2	Goodson Spec	79.99	GV-280-CB
		7" x 1" x 7/8"	Offset	S	White	SVS, SVS-2	010-0707-50	118.99	GV-281
		7" x 1" x 7/8"	Offset	T	Green	SVS, SVS-2	010-0708-05	209.99	GV-282
		7" x 1" x 7/8"	Offset	T	Green	SVS, SVS-2	Goodson Spec	99.99	GV-282A
		7" x 1" x 7/8"	Offset	GP	Orange	SVS, SVS-2	Radiac Spec	83.99	F372239 
		7" x 1 9/16" x 7/8"	Offset	GP	Ruby	SVS, SVS-2	Radiac Spec	83.99	F377419 
		8" x 1 3/8" x 7/8"	Offset	GP	Gray	VL	010-0819-04	124.99	GV-260
Stem	3" x 1 1/4" x 5/8"	Cup	GP	Gray	All Models except VL	Radiac Spec	50.99	F336036 	
	3" x 1 1/4" x 5/8"	Cup	GP	Gray	All Models except VL	010-0300-05	26.99	GV-237	
	3" x 1 1/4" x 5/8"	Cup	CB	Blue	All Models except VL	Goodson Spec	29.99	GV-237-CB	
KO Lee	Valve	5" x 3/4" x 5/8"	Offset	GP	Gray	All models	OV5GH60	101.99	GV-658
		5" x 3/4" x 5/8"	Offset	S	White	All models	OV5GH80S	74.99	GV-659
	Stem	4" x 1" x 5/8"	Cup	GP	Gray	K500(C) & K403(C)	RV4KH60	33.99	GV-345
		4" x 1" x 5/8"	Cup	CB	Blue	All	Goodson Spec	39.99	GV-345-CB
Rottler	Valve	7" x 1" x 7/8"	Offset	GP	Gray	VR-7, VR-10	VTRW-8	69.99	GV-280
		7" x 1" x 7/8"	Offset	CB	Blue	VR-7, VR-10	Goodson Spec	79.99	GV-280-CB
		7" x 1" x 7/8"	Offset	T	Green	VR-7, VR-10	VTRW-7	209.99	GV-282
		7" x 1" x 7/8"	Offset	S	White	VR-7, VR-10		118.99	GV-281
		7" x 1" x 7/8"	Offset	T	Green	VR-7, VR-10	Goodson Spec	99.99	GV-282A
		7" x 1" x 7/8"	Offset	GP	Orange	VR-7, VR-10	Radiac Spec	83.99	F372239 
		7" x 1" x 7/8"	Offset	GP	Ruby	VR-7, VR-10	Radiac Spec	83.99	F377419 
		8" x 1 1/4" x 1 1/2"	Flared	GP	Gray	VR-8	Goodson Spec	251.99	GV-525
		9" x 1 1/4" x 1 1/2"	Offset	GP	Orange	VR-9, VR-12		177.99	GV-725
		9" x 1 1/4" x 1 1/2"	Offset	S	Pink	VR-9, VR-12		164.99	GV-726
		9" x 1 1/4" x 1 1/2"	Offset	T	Green	VR-9, VR-12		164.99	GV-727
		9" x 1 1/4" x 1 1/2"	Offset	S	Ruby	VR-9, VR-12	Nitrite Coated Diesel	164.99	GV-728
		Stem	3" x 1 1/4" x 5/8"	Cup	GP	Gray	VR-7, VR-10	VTRW-9	26.99
3" x 1 1/4" x 5/8"	Cup		CB	Blue	All Models except VL	Goodson Spec	29.99	GV-237-CB	
3" x 1 1/4" x 5/8"	Cup		GP	Gray	VR-7, VR-10	Radiac Spec	50.99	F336036 	
		100 x 50 x 20mm	Cup	GP	White	VR416, VR-516, VTRW-3	7606	60.99	GV-928

Colors may vary due to manufacturing processes. All valve refacing wheels are guaranteed for 1 year from original purchase date.



Valve Refacing Wheels

Colors may vary due to manufacturing processes. All valve refacing wheels are guaranteed for 1 year from original purchase date.



To Fit	Use	Dia x Ht x Arb	Shape	Type	Color	Fits Models	OE No.	Jobber	Order No.
Skil Snap-On	Valve	5" x 3/4" x 5/8"	Offset	GP	Gray	All models	7556/VW80	\$101.99	GV-658
		5" x 3/4" x 5/8"	Offset	S	White	All models	VW80S	74.99	GV-659
Sioux™	Stem	4" x 1" x 5/8"	Cup	GP	Gray	All but Skil 491	7557/VR2M89	33.99	GV-345
		4" x 1" x 5/8"	Cup	CB	Blue	All but Skil 491	Goodson Spec	39.99	GV-345-CB
	Valve	4" x 1" x 5/8"	Offset	CB	Blue	All but 680, 682, 285, 956	Goodson Spec	35.99	GV-146-CB
		4" x 1" x 5/8"	Offset	GP	Gray	All but 680, 682, 285, 956	78SP	36.99	GV-147
		4" x 1" x 5/8"	Offset	GP	Black	All but 680, 682, 285, 956	78E	62.99	GV-148
		4" x 1" x 5/8"	Offset	S	Ruby	All but 680, 682, 285, 956	Goodson Spec	37.99	GV-144
		4" x 1" x 5/8"	Offset	T	Green	All but 680, 682, 285, 956	Goodson Spec	52.99	GV-150
		5" x 1" x 5/8"	Offset/20°	GP	Pink	Thor 299 & 300	Goodson Spec	53.99	GV-156
		7" x 1 1/16" x 1 3/4"	Str./15°	GP	Orange	680, 956, 2001 & 2075	Goodson Spec	63.99	GV-270
		7" x 1 1/16" x 1 3/4"	Str./15°	CB	Blue	680, 956, 2001 & 2075	Goodson Spec	61.99	GV-270-CB
		7" x 1 1/16" x 1 3/4"	Str./15°	S	White	680, 956, 2001 & 2075	177	66.99	GV-271
		7" x 1 1/16" x 1 3/4"	Str./15°	T	Green	680, 956, 2001 & 2075	174	151.99	GV-272
		7" x 1 1/16" x 1 3/4"	Str./15°	GP	Ruby	2001, 2075, 680 & 956	Radiac Spec	52.99	A379613 Radtec
		7" x 1 1/16" x 1 3/4"	Str./15°	T	Green	2001, 2075, 680 & 956	Radiac Spec	52.99	A340229 Radtec
Stem	4" x 1" x 5/8"	Cup	GP	Gray	All but 682 & 685	81 (73533)	33.99	GV-345	
	4" x 1" x 5/8"	Cup	CB	Blue	All but 682 & 685	Goodson Spec	39.99	GV-345-CB	
	4" x 1" x 5/8"	Offset	GP	Gray	All but 682 & 685	Radiac Spec	41.99	F336037 Radtec	
Sunnen® (TA) S&D	Valve	6" x 1 1/16" x 3/4"	Flared	GP	Black	VR6500, all S&D	VR602	161.99	GV-766
		6" x 1 3/8" x 3/4"	Flared	GP	Gray	VR6500	Radiac Spec	154.99	F345291 Radtec
	Stem	5" x 1 1/2" x 3/4"	Cup	S	White	VR6500, all S&D	VR601	90.99	GV-755
Winona Van	Valve	5" x 3/4" x 5/8"	Off./Bev.	GP	Gray	E, Y, YW, X, XA	75399	101.99	GV-658
		5" x 3/4" x 5/8"	Off./Bev.	S	White	K500HM, K403CM	75400	74.99	GV-659
Norman	Stem	4" x 1" x 5/8"	Cup	GP	Gray	All but 500 & CRW	40352	33.99	GV-345
		4" x 1" x 5/8"	Cup	CB	Blue	All but 500 & CRW	Goodson Spec	39.99	GV-345-CB

Colors may vary due to manufacturing processes. All valve refacing wheels are guaranteed for 1 year from original purchase date.



Mineral Based Valve Grinding Oil

- Long-lasting • Cools while grinding
- Removes particles for a better finish
- Inhibits rust • Prevents rancidity, foaming & deposits

Quantity	Jobber	Order No.
1 gallon / 3.79 L	\$ 39.99	VGO-10
5 gallons / 18.93 L	169.99	VGO-50



Valve Grinding Aid For Titanium, Stainless & Stellite Valves

- Not water soluble - add to your mineral based Valve Grinding Oil for better finish on titanium, stainless steel and stellite valves
- Mix ratio: 1:4 • Won't hinder your regular valve grinding process
- Seeks out, and bonds to hot metals
- Ideal for grinding hard metal racing valves • 32 oz. / 946 mL
- Order No. **VGA-T32** Jobber \$51.99



Mix 1 part grinding aid to 4 parts refacer oil



Severe Duty Mineral Based Valve Refacer Oil For Titanium, Inconel®, Stainless Steel & Stellite

- Mineral Based
- Includes additives to improve cutting performance under high pressure

Size	Jobber	Order No.
1 gallon / 3.79 L	\$ 44.99	VGO-SD10
5 gallons / 18.93 L	194.99	VGO-SD50

CYLINDER HEAD REBUILDING
CLEANING, ASSEMBLY & SAFETY
SHORT BLOCK REBUILDING
FLYWHEEL GRINDING
CRANKSHAFT/GRINDING
MISCELLANEOUS TOOLS & SUPPLIES
BRAKE SERVICE TOOLING
MEASURING TOOLS
V-TWIN & METRIC HARD PARTS



"In addition to the wide selection of tools and supplies found in this catalog, we have access to hundreds more hard-to-find tools. If you're looking for a special tool, call us and we'll help you find it."

- Wendy, Goodson Inventory Control, 33 years of service

CYLINDER HEAD
REBUILDING



Replacement Belts For Kwik-Way Valve Refacers

Application	Machine	Jobber	Order No.
1 Spindle Belt 14.5" L "O" Ring - 1 Pr.	SVS II	\$19.99	000-2303-62
2 Chuck Belt 10" Cog, 50 tooth	SVS II	24.99	001-1899-90
3 Spindle Belt 18" Serpentine	SVS	41.99	001-1905-20
4 Chuck Belt 12" Cog, 60 tooth	SVS or VS	28.99	001-1899-99
5 Spindle Belt 16" V-Belt	VS	24.99	001-1900-67
6 Chuck Belt 19" 120 tooth	VS	32.99	001-1900-75

CLEANING,
ASSEMBLY & SAFETY

SHORT BLOCK
REBUILDING

CRANKSHAFT/
FLYWHEEL GRINDING

Replacement Chuck Balls For Kwik-Way Valve Refacers

- Measure chuck ball diameter before ordering to ensure correct replacement • 6 per set

Diameter	Jobber	Order No.
1/2"	\$52.99	010-2101-27
17/32"	45.99	010-2101-35

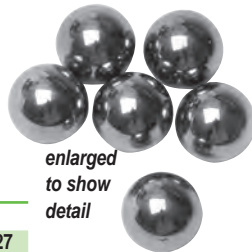

enlarged
to show
detail

MISCELLANEOUS
TOOLS & SUPPLIES



Replacement Bearing Cap for Sioux™ 1710 Electric Driver

- Order No. **SX-23694**
Jobber \$64.99

Replacement Brush Set for Sioux™ 1710 Electric Driver

- Carbon brushes for armature
- Measure 3/8" x 1/2"
- Order No. **SX-18004**
Jobber \$32.99



BRAKE SERVICE
TOOLING

MEASURING
TOOLS

Replacement Switch for Sioux™ 1710 Electric Driver With Plastic Handle

- 125/250 VAC or 125VDC
- 2 Pole • Measures 1.87"L x 0.875"W x 1.07"H
- Order No. **SX-18204**
Jobber \$36.99

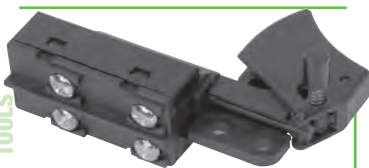

Replacement Bearing Cap for Sioux™ 1792 Pneumatic Driver

- Order No. **SX-33970**
Jobber \$64.99



V-TWIN & METRIC
HARD PARTS

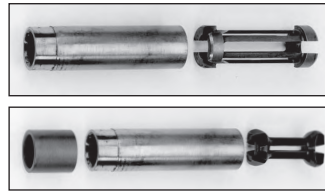

◀ Collet is unavailable from OE

◀ Replace with two-piece set

Collet for Black & Decker™ Valve Refacers

- Two-piece set replaces the Black & Decker Twin Grip collet (no longer available)
- Remove the damaged, worn or broken collet and replace with this set
- Accommodates 1/4" (6.35mm) to 3/8" (9.53mm) valve stems
- Order No. **BVR-38** Jobber \$229.99

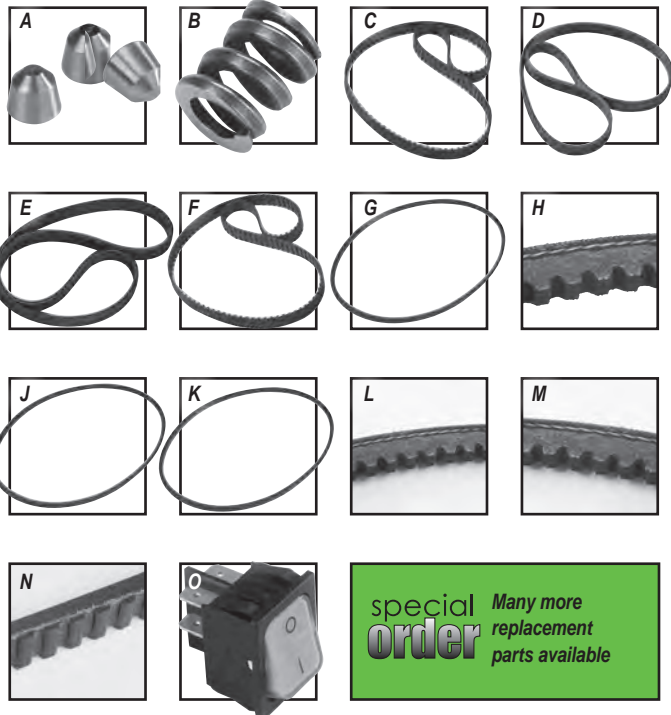

Replacement Parts for Sioux™ Valve Refacers

Description	Fits Model No.	Jobber	Order No.
A- Chuck Balls (3 pc.)	680, 2075	\$242.99	24185
B- Chuck Springs (9 Pcs.)	680, 2075	136.99	SX-53615
C- Cog Style 24"x1/2" 120 teeth	680	17.99	SX-14467
D- Serpentine 29 3/8"x1/2" 5 grooves	680	18.99	SX-14471
E- Spindle Belt 28 3/8"x1/2" 5 groove	2075	39.99	SX-65117
F- Chuck Belt 23 3/8"x3/8" 115 teeth	2075	12.99	SX-14473
G- Replacement Belt for Grinding Head Fits Serial #s up to 34999 (2 belts)	645	13.99	SX-14400
H- Chuck Belt Fits Serial #s 34999 & up (also coolant pump belt for #s 35217 & up).	645	12.99	SX-14401
J- Belt for Motor Shaft; Fits Serial #s up to 34999	645	12.99	SX-14402
K- Coolant Pump Belt; Fits Serial #s 34999-35216	645	12.99	SX-14403
L- Belt for Motor Shaft; Fits Serial #s 35000 & up	645	44.99	SX-14445
M- Replacement Belt for Grinding Head; Fits Serial #s 35000-58700	645	12.99	SX-14453
N- Replacement Belt for Grinding Head; Fits Serial #s 58701 & up	645	39.99	SX-14461
O- Replacement Switch (1100V, AC)	2001, 2075	58.99	SX-18221

special
order Many more
replacement
parts available

Replacement Parts

CYLINDER HEAD
REBUILDING

CLEANING,
ASSEMBLY & SAFETY

SHORT BLOCK
REBUILDING

CRANKSHAFT/
FLYWHEEL GRINDING

MISCELLANEOUS
TOOLS & SUPPLIES

BRAKE SERVICE
TOOLING

MEASURING
TOOLS

V-TWIN & METRIC
HARD PARTS



Replacement V-Belts for Sunnen® VGS-20 Seat & Guide Machine

- Poly V-Belts
- Milled construction
- Shippable worldwide

Application	Length	Replaces OE#	Jobber	Order No.
Drive	22"	PDB-310A/ST-467X	\$30.99	VGS-20-22
Countershaft	30"	PDB-309A/ST-467W	41.99	VGS-20-30

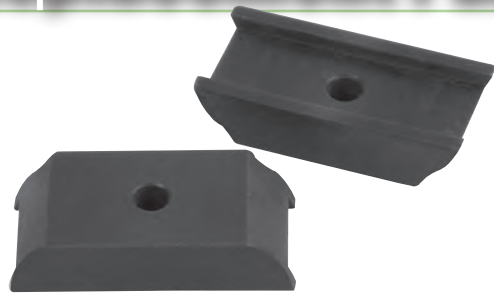

Valve Refacer Steady Rest Shoes for Sunnen® VR-7000 & VR-8000

- Sold by the pair
- Order No **SUN-1202A** Jobber \$43.99

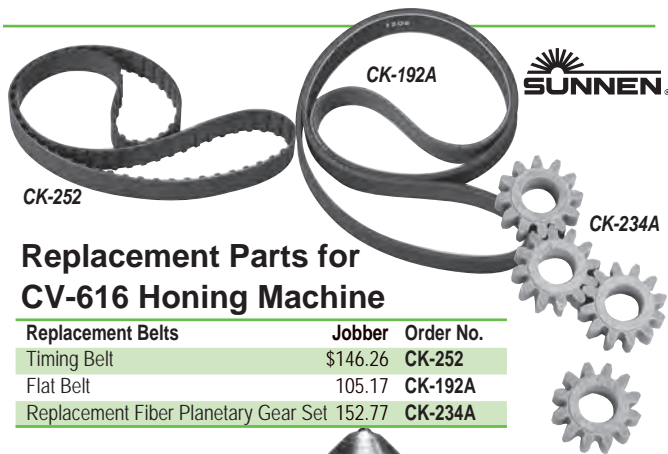

Replacement Parts for CV-616 Honing Machine

Replacement Belts	Jobber	Order No.
Timing Belt	\$146.26	CK-252
Flat Belt	105.17	CK-192A
Replacement Fiber Planetary Gear Set	152.77	CK-234A

Sunnen VR-6500 Valve Refacer Replacement Drive Belts

- 2 sizes available
- Shippable worldwide

Length	OE Number	Jobber	Order No.
11"	PDB-305A	\$13.99	VR-6500-11
17"	PDB-306A	13.99	VR-6500-17

Diamond dressers shown at approximately actual size

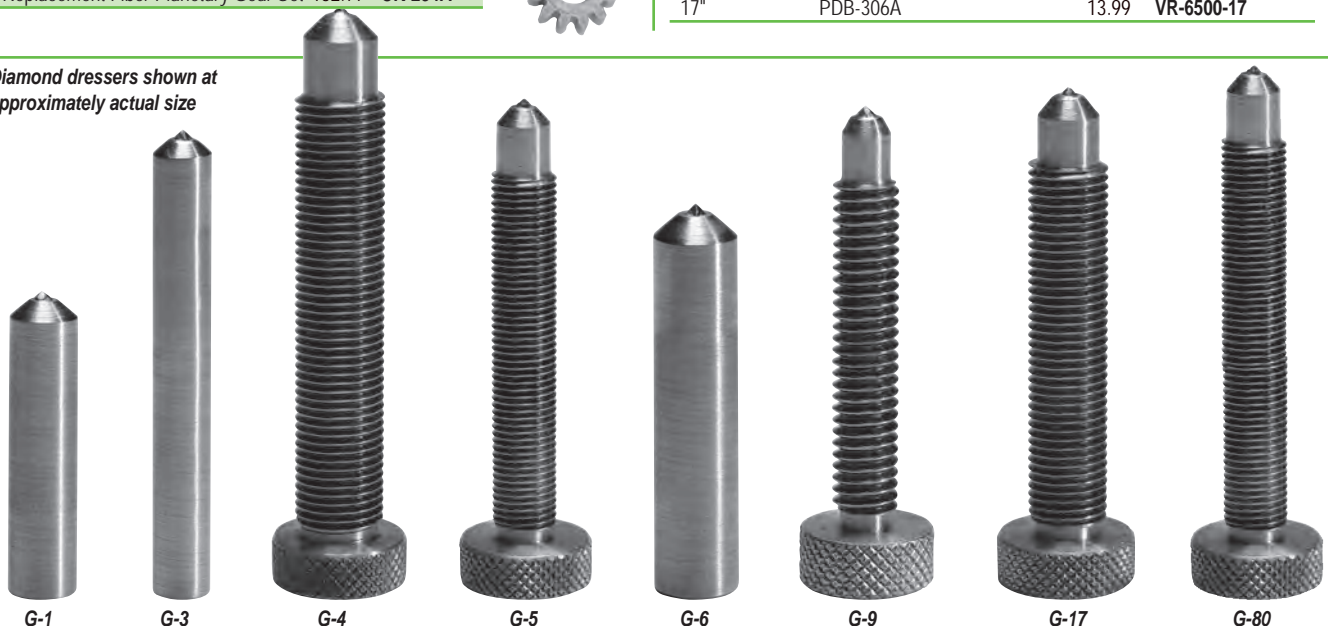

Diamond Dresser Tools for Common Valve Refacers

• Select from Standard or Premium Grade • See the complete assortment of diamond dresser tools on pages 116 and 117.

Machine	Description	Carat	Jobber	Standard	Jobber	Premium	
Valve Refacers	B&D, Skil, Sioux™, Thor, VanDorn, WVN	3/8" x 1 1/8"	1/8	\$42.99	G-1	\$84.99	
	Kwik-Way, Tobin Arp (S&D)	5/16" x 2 1/2"	1/8	42.99	G-3	—	
	Kwik-Way, Valve Master (1714)	1/2" x 3 1/4" 20NF	1/8	44.99	G-4	—	
	Sioux™ (1713, 1715), IDL, WVN (CG50, CG80)	3/8" x 2 3/4" 24NF	1/8	44.99	G-5	84.99	
	IDL, WVN (CG-50, CG-80)	3/8" x 3 1/4" 24NF	1/8	49.99	G-80	—	
	US	7/16" x 2"	1/8	44.99	G-6	—	
	Skil (Talent)	5/16" x 2 1/4" 18NC	1/8	44.99	G-9	—	
	Kwik-Way	7/16" x 2 3/4" 20NF	1/8	42.99	G-17	84.99	
							G-1P
							G-5P
						G-5P	
						G-17P	



"I make sure all Goodson products are packaged properly and include instructions and other important information for you."

- Craig Goodson Receiving - 7 years of service

CYLINDER HEAD
REBUILDING

CLEANING,
ASSEMBLY & SAFETY

SHORT BLOCK
REBUILDING

CRANKSHAFT/
FLYWHEEL GRINDING

MISCELLANEOUS
TOOLS & SUPPLIES

BRAKE SERVICE
TOOLING

MEASURING
TOOLS

V-TWIN & METRIC
HARD PARTS

tech tips
from the techxperts™
For best results,
limit speed to
175 RPM

**High Speed Steel
Core Drill/Reamers**

- Save time – drill and ream in a single pass
- Top-quality, high speed steel
- Prepares the guide bore for standard OD valve guide inserts
- Several shank designs to fit most Seat & Guide machines
- For best results limit speed to 175 RPM

Fits	Size	mm	Jobber	Order No.
Peterson and K.I.	.375" x .500"	9.5x12.7	\$209.99	CDR-6197G
½" round shank				
Serdi	.275" x .437"	7.0x11.1	\$209.99	CDR-7192G
¾" with flat	.275" x .500"	7.0x12.7	209.99	CDR-7193G
	.312" x .437"	7.9x11.1	209.99	CDR-7194G
	.312" x .500"	7.9x12.7	209.99	CDR-7195G
	.343" x .500"	8.7x12.7	209.99	CDR-7196G
	.375" x .500"	9.5x12.7	209.99	CDR-7197G
Cobalt Core Drills/ Reamers				
Size	mm	Jobber	Order No.	
½" round shank	.275" x .437"	7.00x11.1	\$209.99	CDR-274-CB
	.275" x .500"	7.00x12.7	209.99	CDR-275-CB
	.311" x .5628"	7.90x14.3	209.99	CDR-563-CB
	.312" x .500"	7.92x12.7	209.99	CDR-312-CB
	.343" x .500"	8.71x12.7	209.99	CDR-343-CB
	.373" x .625"	9.47x16.5	209.99	CDR-625-CB
	.375" x .500"	9.53x12.7	209.99	CDR-375-CB

High Speed
Steel Core Drill/
Reamers are
62 to 64 Rc

Steam-Oxide
Coating for Chip
Lubricity



**sized for
diesel**

**Valve Guide Tooling
For 5.9 L, 24 Valve, 7mm Cummins**

- To replace integral guides used in this diesel cylinder head
- Replacement guides are .502/.511" stepped to use with OE or replacement seals below

Description	Jobber	Order No.	Includes
Complete Kit	\$439.99	CVG-KIT	▼
Tooling Kit Only	329.99	CVG-59KIT	▼
A Core Reamer (.426" pilot, .485" shank)	169.99	CCR-59	1 1
B Core Drill (7mm pilot, .429" shank)	169.99	CCD-59	1 1
C Guide Driver (7.0mm)	24.99	PHL-2235-G	1 1
D Cast Iron Valve Guide (Exhaust)	4.49	CIG-3022	12
E Cast Iron Valve Guide (Intake)	4.49	CIG-3021	12
F Exhaust Seals (12 pk.)	14.99	CVS-59E	1
G Intake Seals (12 pk.)	14.99	CVS-59i	1

tech tips This application requires you to perform all machining and guide installation from the spring side of the head.



Piloted Core Drills and Reamers

- CNC-machined to .0003" T.I.R. or less
- Ideal for any Bridgeport-type (collet driven) machine
- Use dry at 175 to 225 RPM

Piloted Core Drills

- Center accurately in the guide
- Cutting angle prevents the bit from wandering due to irregular guide wear
- Flutes are designed to enlarge bores quickly

Precision Reamers

- Pilot size is carefully matched to the OD of the related core drill
- Assures accurate location of the reamer for smooth, vibration free operation
- Gives proper interference fit to match manufacturer specifications



Find out more about Piloted Core Drills & Reamers. Scan the code at right with your smart phone or other smart device for instant access



High Speed
Steel Core Drill/
Reamers are
65 to 67 Rc

Bronze-Oxide
Coating for
Chip Lubricity



Core Drills					Core Reamers				
OD	Pilot	OE No.	Jobber	Order No.	OD	OE No.	Jobber	Order No.	
DCM Tech,	.4687"	.312"	DP-1550	\$119.99	DPP-1511B	.500"	66-02147, RR-115	\$119.99	DRR-115
Peterson / K.I.	.4687"	.344"	66-02138, DP-1511	119.99	DPP-1511	.500"	66-02147, RR-115	119.99	DRR-115
½" Round	.468"	.341"		179.99	DPP-1511C	.500"	66-02147, RR-115	119.99	DRR-115
Sunnen® /	.490"	.312"	VGS-156A	119.99	DTA-2082B	.500"	VGS-162A	119.99	DRT-2097
Tobin-Arp	.490"	.343"	VGS-152A	119.99	DTA-2082	.500"	VGS-162A	119.99	DRT-2097
½" with Flat	.490"	.371"	VGS-153A	119.99	DTA-2083	.500"	VGS-162A	119.99	DRT-2097
Universal	.429"	7mm		169.99	CCD-59	.4365"	Use for Ford 6.0L Diesel	144.99	FCR-60-1
.429" Round	.429"	7mm		169.99	CCD-59	.4375"	Use for Ford 6.0L Diesel	144.99	FCR-60
Shank	.429"	7mm		169.99	CCD-59	.4995"	Use for 24V Cummins	169.99	CCR-59
			Use Core Drill/Reamers (CDR) in chart above for sizing		.562"	.500" pilot		169.99	CCR-562B
	.541"	8mm		169.99	CCD-550	.550"	Use for 12V, 5.9 Cummins	169.99	CCR-550

Note: For the best performance, Core Drills and Reamers should be used in matched pairs. If you order a drill slightly smaller or larger than the OE specification to fit your machine, please order the matching reamer listed immediately to the right of the drill in the table.

Bronze Reaming Oil

- Prevents build-up • Extends reamer life • Improves valve guide finish

Size	Jobber	Order No.
1 Pint / 473.2mL	\$10.99	BW-303-G
1 Quart / 946.4mL	17.99	BW-303A-G
1 Gallon / 1.893L	39.99	BW-305-G



tech tips *For best results always use Carbide Reamers with Bronze Reaming Oil (BW-303A-G)*

Extended non-cutting pilot section for easier alignment with the guide

Pilot portion of reamer features 4 flutes to deliver more cutting oil to the work piece

Reamer body features 8 flutes to cut bronze valve guides quickly, accurately and repeatably

tech tips *Once used on cast iron, do NOT use on bronze.*

Small Reamers for Cast Iron or Bronze

- Premium quality reamers with tough cobalt flutes for long life in cast iron or bronze • Square drive shank
- Use at 200 to 300 RPM
- OAL is 4.50" (nominally)

Inch	mm	Shank Dia.	Drive Dia.	Jobber	Order No.
.1575"	4.00	.152"	.112"	\$ 97.99	MR-4MM
.1771"	4.50	.173"	.112"	97.99	MR-4.5MM
.1968"	5.00	.187"	.138"	97.99	MR-5.0MM
.1980"	5.03	.187"	.136"	97.99	MR-198
.2165"	5.50	.206"	.162"	107.99	MR-5.5MM
.2360"	6.00	.224"	.160"	107.99	MR-6.0MM
.2755"	7.00	.246"	.182"	117.99	MR-7.0MM

Solid Carbide Valve Guide Reamers Specifically Designed For Use Only With Bronze Guides

- Unique 8-flute body design with 4-flute pilot for longer tool life
- New cutting geometry requires less torque to drive the reamer
- More rigid tool construction
- Faster feeds than conventional design
- Non-cutting pilot allows easier alignment with guide
- Simply the best bronze valve guide reamer we've created!
- Use at 300 to 400 RPM • OAL: 6.00" (nominal)
- Pilot measures approximately .005" smaller than cutting diameter

Inch	mm	Jobber	Order No.	Inch	mm	Jobber	Order No.
.1968"	5.00	\$215.99	HGR-5.0MM*	.3115"	7.91	\$234.99	HGR-3115
.2165"	5.50	215.99	HGR-5.5MM*	.3120"	7.92	234.99	HGR-3120
.2362"	6.00	234.99	HGR-6MM	.3141"	7.98	234.99	HGR-3140
.2750"	7.00	234.99	HGR-7MM	.3150"	8.00	234.99	HGR-8MM
.2766"	7.03	234.99	HGR-2766	.3410"	8.66	234.99	HGR-3410
.2770"	7.04	234.99	HGR-2770	.3420"	8.69	234.99	HGR-3420
.3110"	7.90	234.99	HGR-3110	.3425"	8.70	234.99	HGR-3425
				.3430"	8.71	234.99	HGR-3430
				.3435"	8.72	234.99	HGR-3435
				.3440"	8.74	234.99	HGR-3440

*Pilot, Flute & Shank Dimensions slightly smaller; call for specific details



High Speed Finish Reamers Exclusively for Cast Iron

Precision size cast iron guides. Piloted and made from the finest tempered steel. With proper care, these reamers will accurately size multiple guides without losing their efficient cutting action. **NOT for hardened or bronze guides.** Use at 400 to 500 RPM. Pilot area measures .012" smaller than cutting diameter.

Inch	mm	Jobber	Order No.
3/16" Square Drive			
.2165"	5.50	\$51.99	WR-5.5MM-G
.217"	5.51	51.99	WR-217-G
.218"	5.54	51.99	WR-218-G
.236"	6.00	51.99	WR-6MM-G
.250"	6.35	51.99	WR-250-G
.256"	6.50	51.99	WR-6.5MM-G
.260"	6.60	51.99	WR-260-G
.273"	6.93	51.99	WR-273-G
.274"	6.96	51.99	WR-274-G
.275"	6.99	51.99	WR-275-G
.2755"	7.00	51.99	WR-7MM-G
.276"	7.01	51.99	WR-276-G
.277"	7.03	51.99	WR-277-G
.278"	7.06	58.99	WR-278-G
.281"	7.14	51.99	WR-281-G

Inch	mm	Jobber	Order No.
1/4" Square Drive			
.310"	7.87	\$51.99	WR-310-G
.311"	7.90	51.99	WR-311-G
.312"	7.92	51.99	WR-312-G
.313"	7.95	51.99	WR-313-G
.314"	7.98	51.99	WR-314-G
.315"	8.00	51.99	WR-8MM-G
.316"	8.03	51.99	WR-316-G
.317"	8.05	51.99	WR-317-G
.341"	8.66	51.99	WR-341-G
.342"	8.69	51.99	WR-342-G
.343"	8.71	51.99	WR-343-G
.3435"	8.72	51.99	WR-3435-G
.344"	8.74	51.99	WR-344-G
.345"	8.76	51.99	WR-345-G
.346"	8.79	51.99	WR-346-G
.354"	9.00	51.99	WR-9MM-G
.355"	9.02	51.99	WR-355-G
.356"	9.04	51.99	WR-356-G
.358"	9.09	51.99	WR-358-G

Inch	mm	Jobber	Order No.
1/4" Square Drive			
.372"	9.45	\$51.99	WR-372-G
.373"	9.47	51.99	WR-373-G
.374"	9.50	51.99	WR-374-G
.375"	9.52	51.99	WR-375-G
.376"	9.55	51.99	WR-376-G
.377"	9.58	51.99	WR-377-G
.378"	9.60	51.99	WR-378-G
.379"	9.63	51.99	WR-379-G
.380"	9.65	51.99	WR-380-G
.386"	9.80	61.99	WR-386-G
.394"	10.00	59.99	WR-10MM-G
.395"	10.03	59.99	WR-395-G
.405"	10.29	59.99	WR-405-G
.433"	11.00	59.99	WR-11MM-G
.436"	11.07	59.99	WR-436-G
.437"	11.10	59.99	WR-437-G
.453"	11.51	59.99	WR-453-G
.472"	12.00	59.99	WR-12MM-G
.499"	12.67	59.99	WR-499-G
.500"	12.70	59.99	WR-500-G

tech tips *from the techxperts™*

For best results, use high speed steel finish reamers exclusively on cast iron. Ream without oil.

See page 39 for Drive Adaptors

... another satisfied customer

"I have been using the Goodson Hyper-Finish Diamond Valve Guide Hone for years. It makes quick and easy work for valve guide sizing. It will not load up, keeps the guide straight and true and gives great results every time. Best money I've spent on a tool."

- Wes Brown, Cycle-Rama, Inc., Pinellas Park, Florida, Goodson customer since 1999

CYLINDER HEAD REBUILDING

CLEANING, ASSEMBLY & SAFETY

SHORT BLOCK REBUILDING

CRANKSHAFT/ FLYWHEEL GRINDING

MISCELLANEOUS TOOLS & SUPPLIES

BRAKE SERVICE TOOLING

MEASURING TOOLS

V-TWIN & METRIC HARD PARTS



Introduced to the World Market in 2010!

Black Diamond Hyper-Finish™ Valve Guide Sizing System

The NEW Black Diamond Hyper-Finish Diamond Valve Guide Sizing System is better than ever. CNC manufactured tooling now has greater accuracy, more durability and better quality. Mandrels are made of black anodized hard plated steel.

With this easy-to-use system you can size guides from .193" to .389" (5.00 to 9.90mm) just by switching out mandrels. Mandrels are sold individually. The Drive Head (HF-100) fits every size mandrel assembly shown in the chart below and features a Quick Change set-up. Hyper-Finish Tooling is NOT interchangeable with Sunnen® (p. 36). Use at 200 RPMs max.

new and improved



Mandrel Retaining Nut
The only piece you need to remove to change the mandrel.

Mandrel

Diamond Abrasive
produces 25 RA finish in soft guides and 8-10 RA in hardened guides. Every mandrel-abrasive assembly is quality checked to ensure it is true and on size.

Size	Range		Mandrel Assembly (abrasive & mandrel)	Abrasive Length	Replacement Abrasive	Replacement Mandrel	Drive Head	Guide Brush
	inch	mm						
5.0mm	.193"-.203"	4.90 - 5.15mm	399.99 BHF-193C	40mm	BHFS-010	BHFM-193	HF-100	GVP-9N
5.5mm	.212"-.232"	5.40 - 5.90mm	399.99 BHF-212C	40mm	BHFS-020	BHFM-212	HF-100	GVP-10N
6.0mm	.232"-.253"	5.90 - 6.40mm	399.99 BHF-232C	40mm	BHFS-020	BHFM-232	HF-100	GVP-10N
6.5mm	.251"-.271"	6.40 - 6.90mm	399.99 BHF-251C	40mm	BHFS-020	BHFM-251	HF-100	GVP-11N
7.0mm	.271"-.311"	6.90 - 7.90mm	399.99 BHF-271C	80mm	BHFS-040*	BHFM-271	HF-100	GVP-11N
.312"	.311"-.350"	7.90 - 8.90mm	399.99 BHF-307C	80mm	BHFS-050*	BHFM-307	HF-100	GVP-1N
.343"	.334"-.374"	8.50 - 9.50mm	399.99 BHF-344C	80mm	BHFS-050*	BHFM-344	HF-100	GVP-2N
.375"	.350"-.389"	8.90 - 9.90mm	399.99 BHF-350C	80mm	BHFS-050*	BHFM-350	HF-100	GVP-3N

Included in Master Kit

*Only these replacement abrasives will fit old style mandrels
 Jobber \$189.99 \$279.99 \$419.99 \$7.99

Choose from the Standard Master Kit or Build Your Own!

Standard Master Kit includes: Driver Head, 4-Mandrel Assemblies (see chart above), 4-Nylon Valve Guide Brushes (7mm to 3/8") and 8 oz. Diamond Honing Oil.
 Order No. BHF-KIT Jobber \$1699.99

Custom Kit includes: Driver Head, 4-Mandrel Assemblies (select from chart above), 4-Nylon Valve Guide Brushes (you pick the sizes - see chart above) and 8 oz. Diamond Honing Oil.
 Order No. BHF-KIT-CUSTOM Jobber \$1699.99

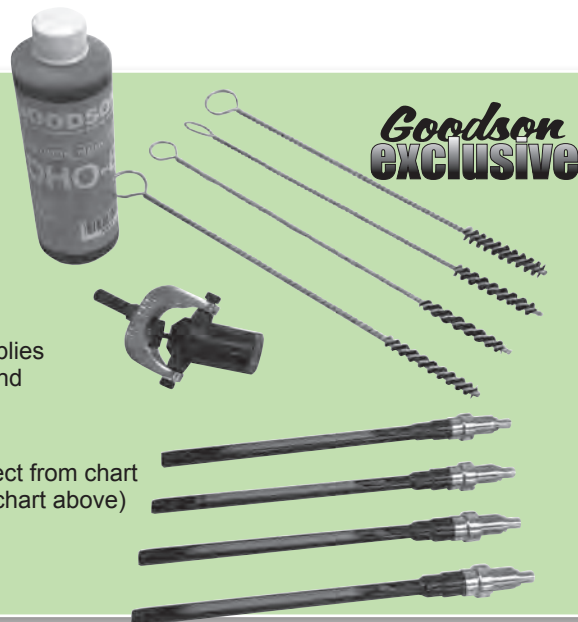

Goodson exclusive



Adjustable hose lets you direct coolant right where you need it

1/2" diameter holes (18) and 1" diameter holes (2) drilled in the top plate provide ample tool storage

Perforated steel grate lets oil through and can be removed for cleaning

Rolled front edge directs splashed coolant back into the sump

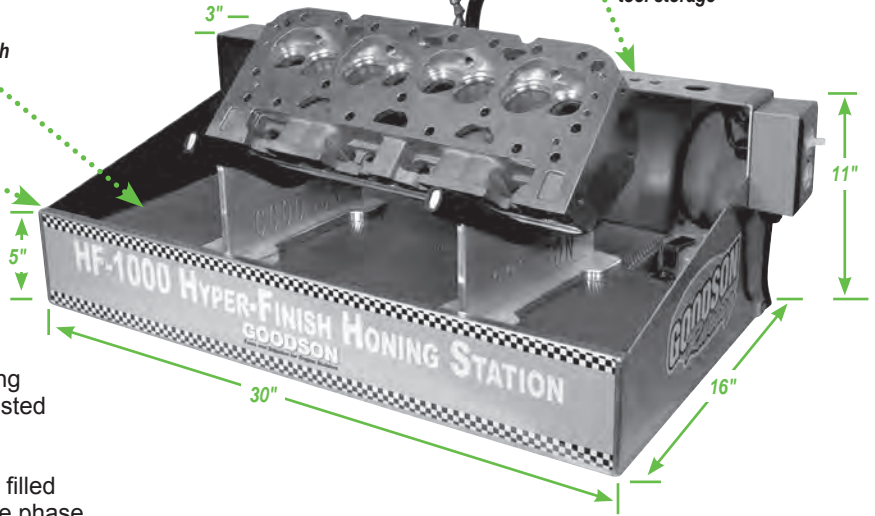

Benchtop Valve Guide Finishing Station

This Goodson designed valve guide finishing station incorporates the features you requested such as:

- Large 5-gallon capacity coolant sump
 - Integral high output pump - 1/150 HP oil filled submersible pump, 115V 60 cycle, single phase heavy-duty motor
 - Aluminum construction for durability and easy cleaning
 - Perforated steel grate allowing used coolant through to recirculate
 - Removable steel grate for easy maintenance
 - Built-in, easy-to-reach storage for tools
- Buy the complete kit and save!**

Description	Jobber	Order No.	Incl.
Complete 110V Valve Guide Finishing Station Kit	\$1189.99	HF-1000KIT	▼
Honing Station Only - 110V	979.99	HF-1000	x
Universal Head Holders	159.99	HH-200	x
Pump 110V	149.99	HF-PUMP	x
5 Gallons Diamond Honing Oil	189.99	DHO-50	x

Export voltage available, contact Goodson for additional information

3/16" diameter shank

Carbide or High Speed Steel Valve Guide Top Cutters

- Matches Seat & Guide machine pilots

Description	Shank	Jobber	Order No.
Cutters 1 1/8" High-Speed Steel	.500"	\$ 64.99	G FH-100
1 1/8" Carbide	.500"	167.99	G FC-200
1 1/8" High-Speed Steel	.486"	147.99	G FH-300
Shank Pilots 3/16" (.1875")	.312" (7.93mm)	17.49	G FP-312
.343" (8.73mm)	.343" (8.73mm)	17.49	G FP-343
.375" (9.53mm)	.375" (9.53mm)	17.49	G FP-375
.437" (11.11mm)	.437" (11.11mm)	17.49	G FP-437
.500" (12.70mm)	.500" (12.70mm)	17.49	G FP-500

Cutter



Valve Guide OD Chamfer Tool

- Improve oil deflection
- Universal cutter chamfers any OD from 1/4" to 5/8" (6.35-15.9mm)
- Most precise when used in a Seat and Guide Machine
- Order No. **GCT-35**
Jobber \$86.99



Diamond Honing Oil

- For high pressure honing
- Recommended for use with Black Diamond Valve Guide Sizing System



Size	Jobber	Order No.
8 oz./237mL	\$ 5.99	DHO-8
1 Gallon/3.79L	42.99	DHO-10
5 Gallons/18.93L	189.99	DHO-50



Valve Guide Top Collar

- Supports guide top during machining
- Protects against damage or breakage
- Ideal for high-performance work, and for installing Bronze-Wall® guide inserts or thin-wall liners (pages 39-41)

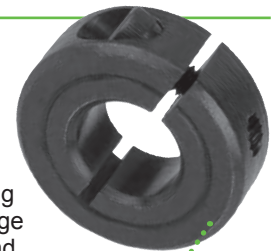

Size	Range	Jobber	Order No.
.500"	.496" -.504"	\$ 9.99	VGC-502
.530"	.526" -.534"	10.99	VGC-530
.566"	.562" -.570"	11.99	VGC-566



CYLINDER HEAD REBUILDING
CLEANING, ASSEMBLY & SAFETY
SHORT BLOCK REBUILDING
FLYWHEEL GRINDING
MISCELLANEOUS TOOLS & SUPPLIES
BRAKE SERVICE TOOLING
MEASURING TOOLS
V-TWIN & METRIC HARD PARTS



"We take our job of getting your order to you quickly very seriously. We use several different carriers allowing us to get your products to you when you need them at a price you can afford."

- Becky, Goodson Shipping Supervisor, 8 years of service

CYLINDER HEAD
REBUILDING



Truing Sleeve

Adaptor

P-180
Hone Head

Silicon-Carbide
Honing Stone

Wedge (included with
Mandrel)

Mandrel

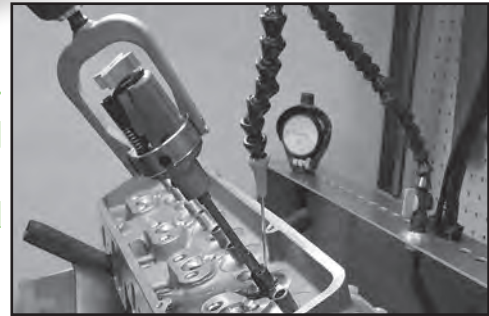

Valve Guide Hone Set

- Sets-up fast • Easy to use!
- Produces straight, round holes for top-quality work
- Ideal for high-performance applications
- Use a low RPM, 1/2" drill for driving power (200 RPM max.)
- Silicon-Carbide Roughing & Finishing Stones
- Sunnen® tooling is NOT interchangeable with Goodson Hyper-Finish (page 34)

CLEANING,
ASSEMBLY & SAFETY

SHORT BLOCK
REBUILDING

CRANKSHAFT/
FLYWHEEL GRINDING

MISCELLANEOUS
TOOLS & SUPPLIES

BRAKE SERVICE
TOOLING

MEASURING
TOOLS

V-TWIN & METRIC
HARD PARTS

Description	Jobber	Order No.
Sunnen Honall® Valve Guide Hone Set	\$968.68	P-190
Includes: Head & Driver. Mandrels & Sleeves (1 of ea. for sizes - 5/16", 11/32", 3/8", & 7/16")		
Adaptors: (1) PK10-A & (1) PK12-A. Stones L10-J69 & L12-J67. Case & instructions		
Sunnen Honall® Valve Guide Hone Head & Driver only	\$475.69	P-180

Ordering Information: The head and driver are interchangeable with the adaptors.

tech tips

from the techxperts™

Only one head and driver is required. Mandrels are available to cover all popular sizes. Please select from the parts in the photo above and order per size range desired. We suggest you have an adaptor for each mandrel to save change-over time between sizes.

BL Mandrels (Order Mandrel, Sleeve, Stones, Adaptor & Stone Retainer Separately)

Range			Mandrel		Sleeve		Roughing Stones		Finishing Stones		Adaptor		Stone Retainer	
Size	Inch	mm	Jobber	Order No.	Jobber	Order No.	Jobber	Order No.	Jobber	Order No.	Jobber	Order No.	Jobber	Order No.
5mm	.195"-.200"	4.9-5.1	\$47.47	BL6-195CS	\$15.16	S-195	\$87.77	L6-J47 (12)	\$87.77	L6-J67 (12)	\$92.99	PSK6-A ‡	\$12.93	LN-3087C
5.5mm	.210"-.215"	5.3-5.5	47.47	BL6-210CS	15.16	S-210	87.77	L6-J47 (12)	87.77	L6-J67 (12)	92.99	PSK6-A ‡	12.93	LN-3087C
	.215"-.220"	5.5-5.6	47.47	BL6-215CS	15.16	S-215	87.77	L6-J47 (12)	87.77	L6-J67 (12)	92.99	PSK6-A ‡	12.93	LN-3087C
	.225"-.230"	5.7-5.8	47.47	BL6-225CS	15.16	S-225	87.77	L6-J47 (12)	87.77	L6-J67 (12)	92.99	PSK6-A ‡	12.93	LN-3087C
6mm	.230"-.235"	5.8-6.0	47.47	BL6-230CS	15.16	S-230	87.77	L6-J47 (12)	87.77	L6-J67 (12)	92.99	PSK6-A ‡	12.93	LN-3087C
	.235"-.240"	6.0-6.1	47.47	BL6-235CS	15.16	S-235	87.77	L6-J47 (12)	87.77	L6-J67 (12)	92.99	PSK6-A ‡	12.93	LN-3087C
1/4"	.245"-.250"	6.2-6.4	46.53	BL8-245AS	16.46	S-245	48.72	L8-J47 (6)	48.72	L8-J67 (6)	92.99	PK8-A	---	---
	.250"-.255"	6.4-6.5	46.53	BL8-250AS	16.46	S-250	48.72	L8-J47 (6)	48.72	L8-J67 (6)	92.99	PK8-A	---	---
	.255"-.260"	6.5-6.6	46.53	BL8-255AS	16.46	S-255	48.72	L8-J47 (6)	48.72	L8-J67 (6)	92.99	PK8-A	---	---
	.270"-.275"	6.8-7.0	46.53	BL8-270AS	16.46	S-270	48.72	L8-J47 (6)	48.72	L8-J67 (6)	92.99	PK8-A	---	---
	.275"-.280"	7.0-7.1	46.53	BL8-275AS	16.46	S-275	48.72	L8-J47 (6)	48.72	L8-J67 (6)	92.99	PK8-A	---	---
5/16" ♦	.308"-.316"	7.8-8.0	48.21	BL10-308AS	16.46	S-308	51.28	L10-J47 (6)	51.28	L10-J69 (6)	92.99	PK10-A	---	---
11/32" ♦	.339"-.347"	8.6-8.8	48.21	BL10-339AS	16.46	S-339	51.28	L10-J47 (6)	51.28	L10-J69 (6)	92.99	PK10-A	---	---
23/64"	.354"-.362"	9.0-9.2	48.21	BL10-354AS	16.46	S-354	51.28	L10-J47 (6)	51.28	L10-J69 (6)	92.99	PK10-A	---	---
3/8" ♦	.370"-.385"	9.4-9.8	51.04	BL12-370AS	21.81	S-370	56.38	L12-J47 (6)	56.38	L12-J67 (6)	92.99	PK12-A	---	---
7/16" ♦	.432"-.447"	11.0-11.4	51.04	BL12-432AS	21.81	S-432	56.38	L12-J47 (6)	56.38	L12-J67 (6)	92.99	PK12-A	---	---

♦ Included in set Order No. P-190 ‡NOTE: Remove the stone retainer included with the PSK6-A and replace with LN-3087C for valve guide honing



Minnesota Fast Freeze

- Instantly chills seats & guides to -50°F (-45.5°C) • Creates interference fit with heated aluminum heads • Finish seat and guide work faster than ever • Aerosol*
- Use on tight bushings, pins, shafts, etc.
- 10 oz. can

Description	Jobber 1+	Jobber 6+	Order No.
Minnesota Fast Freeze	\$38.99	\$35.09	MFF-8

Order 6 or more to Save 10% off Jobber

*Hazardous Goods Fees Apply When Shipped by Air



6 Piece Valve Guide Flex-Hone® Set

- Kit includes the most popular sizes for valve guide work • 240 Grit Silicon-Carbide

	Jobber	Order No.	Incl.
6 Pc. Valve Guide Kit	\$91.99	VGf-KIT	▼
Size mm OAL			
1/4"	6.4	8"	\$23.99 VGF-6.4MM x
5/32"	7.0	8"	\$23.99 VGF-7MM x
5/16"	8.0	8"	\$23.99 VGF-8MM x
11/32"	9.0	8"	\$23.99 VGF-9MM x
3/8"	10.0	8"	\$23.99 VGF-10MM x
7/16"	11.0	8"	\$23.99 VGF-11MM x

More Valve Guide Flex-Hones® on page 85

Order 3 or more Flex-Hones®, Save 10% off Jobber





Valve Guide Replacement

Valve Guide Drivers

- Corrosion-resistant finish 1° negative angle prevents guides from spreading • Rockwell hardness of 45-50
- Pilots are slightly smaller than guide ID for easy removal



Powered Drivers				
Standard Sizes		Jobber	Order No.	Incl.
4-piece Kit		\$78.99	PH-2226-G	▼
Guide ID /mm	Driver OD	Pilot		
.312" / 7.92	.487" / 12.4	.300" / 7.62	\$20.99 PH-2228A-G	
.312" / 7.92	.423" / 10.7	.304" / 7.72	20.99 PH-2228-G	x
.343" / 8.71	.422" / 10.7	.336" / 8.53	20.99 PH-2229A-G	
.343" / 8.71	.487" / 12.4	.337" / 8.56	20.99 PH-2229-G	x
.372" / 9.47	.487" / 12.4	.367" / 9.32	20.99 PH-2231-G	x
.437" / 11.10	.612" / 15.5	.429" / 10.90	20.99 PH-2230-G	x

Metric Sizes				
6-piece Kit		Jobber	Order No.	Incl.
6-piece Kit		\$119.99	PH-2600-G	▼
Guide ID /in.	Driver OD	Pilot		
5.0mm / .196"	9.0 / .355"	4.75 / .187"	\$20.99 PH-2250-G	x
5.5mm / .217"	10.5 / .412"	5.21 / .205"	20.99 PH-2255-G	x
6.0mm / .236"	10.5 / .412"	5.72 / .225"	20.99 PH-2260-G	x
6.6mm / .260"	11.8 / .463"	6.30 / .248"	20.99 PH-2234-G	x
7.0mm / .275"	11.0 / .432"	6.60 / .260"	20.99 PH-2235-G	x
8.0mm / .315"	11.7 / .462"	7.80 / .307"	20.99 PH-2236-G	x
9.0mm / .353"	12.4 / .487"	8.81 / .347"	20.99 PH-2237-G	
10mm / .393"	15.5 / .612"	9.82 / .387"	20.99 PH-2238-G	
11mm / .433"	15.5 / .612"	10.85 / .427"	20.99 PH-2239-G	

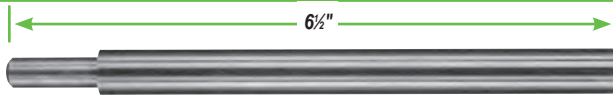

Manual Drivers				
Standard Sizes		Jobber	Order No.	Incl.
4-piece Kit		\$64.99	GP-500A-G	▼
Guide ID /mm	Driver OD	Pilot		
.312" / 7.92	.422" / 10.7	.305" / 7.75	\$19.99 GP-431-G	x
.312" / 7.92	.487" / 12.4	.302" / 7.67	19.99 GP-531-G	x
.343" / 8.71	.422" / 10.7	.336" / 8.53	19.99 GP-533-G	
.343" / 8.71	.487" / 12.4	.336" / 8.53	19.99 GP-534-G	x
.372" / 9.47	.487" / 12.4	.367" / 9.32	19.99 GP-537-G	x
.437" / 11.10	.611" / 15.5	.428" / 10.87	19.99 GP-743-G	
Metric Sizes		Jobber	Order No.	Incl.
6-piece Kit		\$97.99	GP-600M-G	▼
Guide ID /in.	Driver OD	Pilot		
6.6mm / .260"	11.7 / .462"	6.22 / .245"	\$19.99 GP-6.6MM-G	x
7mm / .275"	10.7 / .422"	6.78 / .267"	19.99 GP-7MM-G	x
8mm / .315"	12.3 / .486"	7.77 / .306"	19.99 GP-8MM-G	x
9mm / .353"	12.3 / .485"	8.84 / .348"	19.99 GP-9MM-G	x
10mm / .393"	15.5 / .611"	9.82 / .387"	19.99 GP-10MM-G	x
11mm / .433"	15.5 / .611"	10.82 / .426"	19.99 GP-11MM-G	x



Air Hammer

- Delivers 3500 blows per minute
- Weighs 3 lbs.
- .401" tool opening

Description	Jobber	Order No.
Air Hammer	\$84.99	AH-335
Replacement		
Retainer Spring	10.79	AH-5RS

Universal Driver Tool

- Will fit Diesel Guide Drivers at right to increase your reach
- 4.75" OAL
- .401" ID
- Order No. **CL-7333** Jobber \$45.99

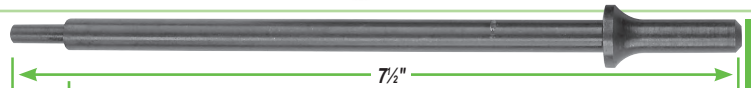

Extra-Long Powered Valve Guide Drivers

- For use with overhead cam heads
- 1° negative angle to prevent guide mushrooming
- Pilots are slightly smaller than guide ID • 7.5" long

Guide ID / in.	Driver OD	Pilot	Jobber	Order No.
4.0mm / .157"	9.0 / .355"	3.80 / .150"	\$24.99	PHL-2240-G
4.5mm / .177"	9.0 / .355"	4.30 / .170"	24.99	PHL-2245-G
5.0mm / .196"	9.0 / .355"	4.75 / .187"	24.99	PHL-2250-G
5.5mm / .217"	10.5 / .412"	5.21 / .205"	24.99	PHL-2255-G
6.0mm / .230"	9.1 / .358"	5.72 / .225"	24.99	PHL-2258-G
6.0mm / .236"	10.5 / .412"	5.72 / .225"	24.99	PHL-2260-G
6.6mm / .260"	11.8 / .463"	6.29 / .248"	24.99	PHL-2234-G
7.0mm / .275"	11.0 / .432"	6.60 / .260"	24.99	PHL-2235-G
7.9mm / .312"	10.7 / .423"	7.72 / .304"	24.99	PHL-2228-G
8.0mm / .315"	11.7 / .462"	7.80 / .307"	24.99	PHL-2236-G
8.7mm / .343"	12.4 / .487"	8.56 / .337"	24.99	PHL-2229-G
9.5mm / .375"	12.4 / .487"	9.32 / .367"	24.99	PHL-2231-G



Extra Long Manual Valve Guide Drivers

- 8" OAL • Pilot approximately 1" long
- NOTE:** Due to the nature of these valve guide drivers, they cannot be warranted against breakage, but are guaranteed for dimensional accuracy.

Guide ID / in.	Driver OD	Pilot	Jobber	Order No.
4.0mm / .157"	9.0 / .355"	3.80 / .150"	\$22.99	GPL-2240-G
4.5mm / .177"	9.0 / .355"	4.30 / .170"	22.99	GPL-2245-G
5.0mm / .196"	9.0 / .355"	4.75 / .187"	22.99	GPL-2250-G
5.5mm / .217"	10.5 / .412"	5.21 / .205"	22.99	GPL-2255-G
6.0mm / .230"	9.1 / .358"	5.72 / .225"	22.99	GPL-2258-G
6.0mm / .236"	10.5 / .412"	5.72 / .225"	22.99	GPL-2260-G

sized for **diesel**

Air-Powered Valve Guide Drivers for Diesel Engines

- Drive guides in from the shoulder instead of from the top
- Installing drivers have the proper recess to drive guides in for the correct installed height • Remove / Install guides faster – no measuring necessary
- For most standard pneumatic tools

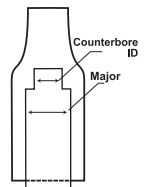
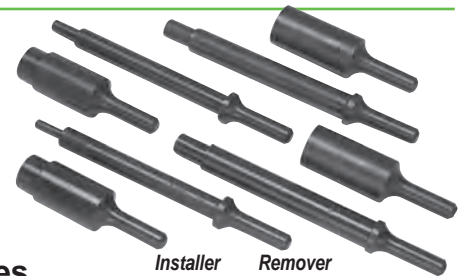

Application	Installer Major/ Counter Bore ID	Order No.	Remover Shank/Pilot OD	Order No.
Cummins	.752" / .503"	DVG-Ci	.595" / .450"	DVG-CR
Cummins 8.3 6CT	.552" / —	DVG-8.3	.491" / .304"	DVG-71R
Caterpillar 3116	.515" / .475"	DVG-3116	.491" / .304"	DVG-71R
Caterpillar 3126	.633" / .506"	DVG-3126	.595" / .354"	DVG-3468R
Caterpillar 3306	.660" / —	DVG-3306	.595" / .354"	DVG-3468R
Caterpillar 3406-3408	.709" / —	DVG-3468i	.595" / .354"	DVG-3468R
Detroit GMC 53	.502" / .421"	DVG-53i	.491" / .246"	DVG-53R
Detroit GMC 71/92	.502" / .435"	DVG-71i	.491" / .304"	DVG-71R
International DT 466	—	—	.595" / .354"	DVG-3468R

Jobber \$34.99

Jobber \$34.99



"We work hard to have the right stock at the right price at the right time so you get your orders on time."

- Nancy, Goodson Inventory Fulfillment Manager, 27 years of service

CYLINDER HEAD
REBUILDING

CLEANING,
ASSEMBLY & SAFETY

SHORT BLOCK
REBUILDING

CRANKSHAFT/
FLYWHEEL GRINDING

MISCELLANEOUS
TOOLS & SUPPLIES

BRAKE SERVICE
TOOLING

MEASURING
TOOLS

V-TWIN & METRIC
HARD PARTS



tech tips
from the techxperts™

Install guides to same height every time!



Pneumatic Driver Body (AVG-1)

Locking Nut (AVG-2) and installation sleeve have flats for positive lock and release adjustment.

Adjustable installation sleeve (AVG-3) adjusts from 0" to 1 1/4" guide height and fits guides to .700" OD.

Adjustable Powered Valve Guide Driver With Replaceable Pilots

- Standardize the correct installed height on one guide then repeat it on all others
- Screw-in pilots with 5/16" - 18 threads • 6 1/2" overall length

Description	Jobber	Order No.	Includes
Standard Valve Guide Driver Kit	\$144.99	AVG-STD	▼
Metric Valve Guide Driver Kit	149.99	AVG-MM	▼
Pneumatic Body Only 5/8"-18 thread	53.99	AVG-1	x x
Installation Sleeve	26.99	AVG-3	x x
Locking Nut	11.99	AVG-2	x x
Replaceable Pilots			
Diameter			
.312"	\$23.99	AVG-312	x
.343"	23.99	AVG-343	x
.372"	23.99	AVG-372	x
.437"	23.99	AVG-437	x
5.0mm	23.99	AVG-5MM	x
5.5mm	23.99	AVG-55MM	x
6.0mm	23.99	AVG-6MM	x
7.0mm	23.99	AVG-7MM	x
8.0mm	23.99	AVG-8MM	x
9.0mm	23.99	AVG-9MM	x

Cast Iron and Manganese Bronze Valve Guides for Harley-Davidson on page 136



Universal Repair Guides

- Unfinished ID ready to be reamed with Goodson's exclusive carbide reamers (page 33)
- Manganese bronze

ID	OD	Length	Job. 1+	Job. 25+	Job. 51+	Order No.
7.0mm	.740"	2.700"	\$10.29	\$9.26	\$8.74	UVBG-7MM
.308"	.740"	2.700"	10.29	9.26	8.74	UVBG-308
.341"	.740"	2.700"	10.29	9.26	8.74	UVBG-341
.372"	.740"	2.700"	10.29	9.26	8.74	UVBG-372

Valve Guide OD Machining Tool

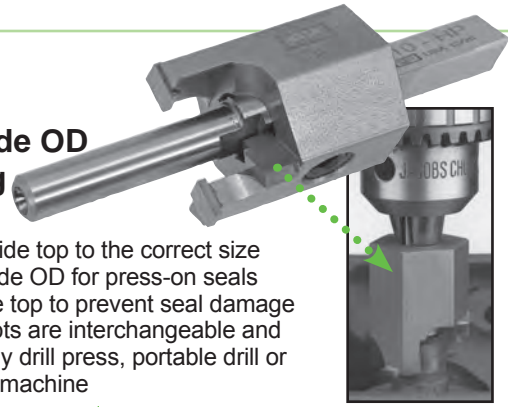

- Faces the guide top to the correct size
- Sizes the guide OD for press-on seals
- Chamfers the top to prevent seal damage
- Cutters & pilots are interchangeable and chuck into any drill press, portable drill or seat & guide machine

Individual Cutters	
Guide OD	Order No.
.415" 10.5	VSC-415
.428" 10.8	VSC-428
.475" 12.1	VSC-475
.495" 12.6	VSC-495
.500" 12.7	VSC-500
.530" 13.5	VSC-530
.562" 14.3	VSC-562
.625" 15.9	VSC-625
Jobber ea.	\$99.99
Pilots	
Guide ID	Order No.
.275" 7.0	VP-7MM
.312" 7.9	VP-312
.343" 8.7	VP-343
.375" 9.5	VP-375
Jobber ea.	\$37.99

Cutter and Pilot Assemblies			
Guide OD	Pilot Size	Order No.	
.415" 10.5	.312" 7.9	VSC-415312	
.420" 10.7	.312" 7.9	VSC-420312	
.428" 10.9	.312" 7.9	VSC-428312	
.475" 12.1	.312" 7.9	VSC-475312	
.475" 12.1	.343" 8.7	VSC-475343	
.500" 12.7	.275" 7.0	VSC-500275	
.500" 12.7	.312" 7.9	VSC-500312	
.500" 12.7	.343" 8.7	VSC-500343	
.500" 12.7	.375" 9.5	VSC-500375	
.530" 13.5	.312" 7.9	VSC-530312	
.530" 13.5	.343" 8.7	VSC-530343	
.530" 13.5	.375" 9.5	VSC-530375	
.562" 14.3	.343" 8.7	VSC-562343	
.562" 14.3	.375" 9.5	VSC-562375	
.625" 15.9	.375" 9.5	VSC-625375	
Jobber ea.		\$129.99	

The more guides you buy, the more you save!

- Buy 25 - 50 guides, save 10% off jobber.
- Buy 51+ guides, save 15% off jobber (mix & match sizes)



Harley valve guides on page 136

Cast Iron False Valve Guides

Universal Applications						
ID	OD	Length	Job. 1+	Job. 25+	Job. 51+	Order No.
.312"	.439"	2.281"	\$4.49	\$4.04	\$3.82	CIG-312
.342"	.502"	3.062"	4.49	4.04	3.82	CIG-342
.372"	.502"	2.750"	4.49	4.04	3.82	CIG-372
.343"	.564"	2.750"	4.39	3.95	3.73	OG-343
.373"	.564"	2.750"	4.39	3.95	3.73	OG-373

24 Valve 7mm Cummins Diesel (.511" seal surface) see tooling, page 32						
ID	OD	Length	Job. 1+	Job. 25+	Job. 51+	Order No.
Intake	.275"	.502" 1.940"	\$4.49	\$4.04	\$3.82	CIG-3021
Exhaust	.275"	.502" 2.020"	4.49	4.04	3.82	CIG-3022
Ford 6.0L (.513" x 659" seal surface) see tooling, page 32						
	.275"	.4395" 2.332"	\$4.49	\$4.04	\$3.82	CIG-3055
7.3 Powerstroke Use with Core Drill Reamer CDR-563-CB, page 32						
	.3146"	.5652" 2.440"	\$4.49	\$4.04	\$3.82	CIG-8476

Manganese Bronze False Valve Guides

Universal Applications						
ID	OD	Length	Job. 1+	Job. 25+	Job. 51+	Order No.
.311"	.439"	3.062"	\$6.49	\$5.84	\$5.52	BVG-311
.343"	.502"	2.375"	6.49	5.84	5.52	BVG-343
.372"	.502"	2.375"	6.49	5.84	5.52	BVG-372

Goodson sized for





Bronze bushings thread easily into tapped bores. Replace guides at any time by simply uncoiling the old ones.

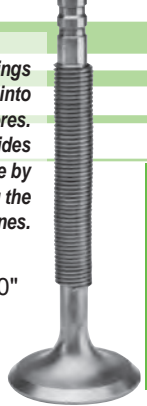

Bronze-Wall® Bushings

- Spiral inserts rebuild cast-iron guides worn .030"
- Highly durable Phosphor-Bronze
- Thread easily into tapped bore
- Helps guides and stems last longer
- .038" wire for reamed guides

Size	Qty.	Jobber 1+	Jobber 2+	Jobber 5+	Order No.
Standard Bushings					
1 1/32"	50	\$73.99	\$66.59	\$59.19	BW-020B-G
3/8"	50	73.99	66.59	59.19	BW-050B-G

The more you buy, the more you save!

2-4 boxes of bushings, save 10% off jobber,
5 or more boxes, save 20% off jobber



Bronze-Wall® 2 Bushings

- Spiral inserts rebuild cast-iron guides worn .030"
- Highly durable Phosphor-Bronze
- Thread easily into tapped bore
- Helps guides and stems last longer
- .035" wire for broached guides
- Easy to install and size using Sizing Ball and Driver instead of Broach and Reamer

Size	Qty.	Jobber 1+	Jobber 2+	Jobber 5+	Order No.
Standard Bushings					
1 1/32"	50	\$73.99	\$66.59	\$59.19	BW2B-343
3/8"	50	73.99	66.59	59.19	BW2B-375

tech tips
from the techxperts™
Use with Knurlube

Knurling Arbors

- Piloted for positive centering
- Use by hand or with electric drill & speed reducer
- **Not for use on chilled, hardened or bronze guides**

Inch	mm	Jobber	Order No.
.236"	6.00	\$104.99	WKA-6MM-G
.275"	7.00	104.99	WKA-7MM-G
.312"	7.92	104.99	WKA-312-G
.343"	8.71	104.99	WKA-343-G
.375"	9.53	104.99	WKA-375-G
1 Quart Knurlube (946.6mL)		19.99	WLB-47-G



Electric Drill Drive Adaptors For Knurling Arbors and/or Reamers



Use **WSR-41-3-G** (1/4" sq.) or **WSR-41-4-G** (3/16" sq.) with **WSR-41-7-G** (3/8" drill adaptor). Clamp 3/8" drive in drill to drive reamers directly.

Description	Jobber	Order No.
A Drill Adaptor for 3/8" drill	\$ 9.99	WSR-41-7-G
B 1/4" Adaptor for arbors/reamers larger than .281"	11.99	WSR-41-3-G
C 3/16" Adaptor for arbors/reamers .281" or smaller	16.99	WSR-41-4-G
D Slip on Adaptor (converts WSR-41-3-G to .1875")	42.99	WSR-41-5-G

Knurlube

- High pressure lube prevents tool damage
- Extends knurler life by reducing friction and arbor wear



Size	Jobber	Order No.
8 oz. / 236.6mL	\$11.99	WLB-46-G
32 oz. / 946.4mL	19.99	WLB-47-G

Bronze Reaming Oil

- Prevents build-up
- Extends reamer life
- Improves valve guide finish



Size	Jobber	Order No.
16 oz. / 473.2mL	\$10.99	BW-303-G
32 oz. / 946.4mL	17.99	BW-303A-G
1 Gal. / 1.893L	39.99	BW-305-G

Valve Guide OD Knurling Tool

- Enlarge guides to fit bore
- Ideal for rare metric sizes and aluminum heads with damaged guide bores
- Works on most materials, **except** chilled or hardened guides

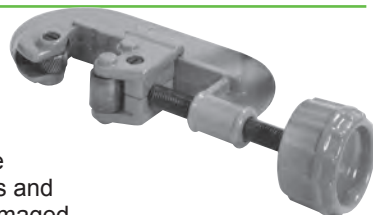

tech tips
from the techxperts™

Hold guide firmly in Vise, Drill Press or Seat & Guide machine; tighten the knurler and turn it around the guide **by hand**. Increase OD up to .002".

Description	Jobber	Order No.
Complete Tool	\$64.99	VGK-25
Replacement Knurling Wheel	24.99	VGK-25W
Replacement Knurling Rollers (2)	10.99	VGK-25R

tech tips
from the techxperts™

Right Hand Rotation Only.

For best results, keep your RPM about the same as your hone RPM, use the same rate of speed and number of strokes per minute.



Ultra-Finish Plateau Valve Guide Soft Hones

- Use AFTER guide honing to remove microscopic peaks and scuffs without enlarging the guide ID
- Abrasive impregnated nylon bristles
- Use with liberal amounts of honing oil
- Not interchangeable with Flex-Hones®
- Use with your portable drill or seat and guide machine

Hole Diameter	Hone	Head	Overall	Jobber	Order No.	
in	mm	Dia.	Length	Length		
.2187"	5.5	.241"	1.00"	4.00"	\$11.99	UF-5.5MM
.2500"	6.4	.275"	1.25"	4.50"	11.99	UF-6.4MM
.2813"	7.0	.309"	1.25"	4.50"	11.99	UF-7MM
.3125"	8.0	.343"	1.25"	4.50"	11.99	UF-8MM
.3437"	9.0	.378"	1.25"	4.50"	11.99	UF-9MM
.3750"	10.0	.413"	1.25"	4.50"	11.99	UF-10MM

NOTE: Larger size Ultra-Finish hones on page 94

CYLINDER HEAD REBUILDING
CLEANING, ASSEMBLY & SAFETY
SHORT BLOCK REBUILDING
FLYWHEEL GRINDING
CRANKSHAFT/ TOOLS & SUPPLIES
MISCELLANEOUS
BRAKE SERVICE TOOLING
MEASURING TOOLS
V-TWIN & METRIC HARD PARTS

... another satisfied customer

"I have been using your products for over 30 years and have never had an issue. Your phone staff is friendly and helpful; my parts are packaged perfectly and the quality of your products is excellent. Keep up the good work."

— Brad Mattei, Mattei's Cycle Supply, New Orleans, LA, Goodson Customer Since 1990

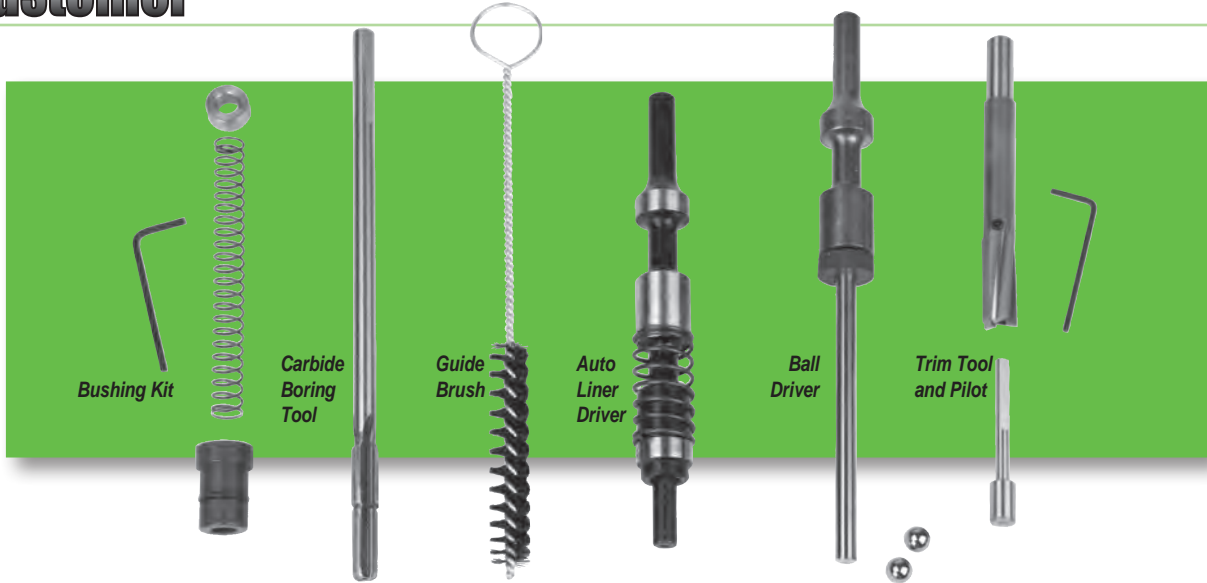

6.0mm to 3/8" Bronze-Liner Installation Tool Kits

Phosphor-Bronze is an ideal valve guide material – it's more durable than cast iron, conducts heat away faster and retains lubrication better to reduce wear. Install rugged, thin-wall (.030") Bronze-Liners in cast iron or aluminum heads to repair guides and deliver performance better than new! Plus, Bronze-Liners install quickly with simple tools. If a Bronze-Liner ever wears out, you can quickly and easily replace it with a new one to restore performance. **Removal Tools, page 41.**

Kits include ▼	6.0mm Guides		7.0mm Guides		5/16" Guides	
Master Tool Kits	\$679.99	CL-6MM	\$649.99	CL-7MM	\$699.99	CL-312
Carbide Boring Tool	269.99	CL-2024C	232.99	CL-2007C	269.99	CL-2005C
Bushing Kit	28.99	CL-2003	26.99	CL-2001	26.99	CL-2000
Ball Driver	94.99	CL-4452P	94.99	CL-4446P	94.99	CL-4444P
Carbide Sizing	54.99	.2370" CL-5237	54.99	.2770" CL-5277	54.99	.3125" CL-53125
Balls	54.99	.2380" CL-5238	54.99	.2780" CL-5278	54.99	.3130" CL-5313
Auto-Driver	129.99	CL-3600	129.99	CL-3507	129.99	CL-3500
Trim Tool	91.99	.402" OD CL-5602	91.99	.500" OD CL-5600	91.99	.500" OD CL-5600
Trim Tool Pilot	29.99	CL-5634	29.99	CL-5626	29.99	CL-5620
Guide Brush	7.99	GVP-10N	4.49	WCB-44	4.49	WCB-44

When Working By Hand, Kits Require Seat Centering Cones - See Chart Below

Kits include ▼	8.0mm Guides		11/32" Guides		3/8" Guides	
Master Tool Kits	\$699.99	CL-8MM	\$699.99	CL-343	\$699.99	CL-375
Carbide Boring Tool	269.99	CL-2008C	249.99	CL-2012C	269.99	CL-2014C
Bushing Kit	26.99	CL-2000	26.99	CL-2000	26.99	CL-2000
Ball Driver	94.99	CL-4444P	94.99	CL-4444P	94.99	CL-4444P
Carbide Sizing	54.99	.3160" CL-5316	54.99	.3440" CL-5344	54.99	.3750" CL-5375
Balls	54.99	.3170" CL-5317	54.99	.3445" CL-53445	54.99	.3760" CL-5376
Auto-Driver	129.99	CL-3500	129.99	CL-3504	129.99	CL-3506
Trim Tool	91.99	.500" OD CL-5600	91.99	.500" OD CL-5600	91.99	.500" OD CL-5600
Trim Tool Pilot	29.99	CL-5620	29.99	CL-5622	29.99	CL-5624
Guide Brush	4.49	WCB-44	4.49	WCB-44	4.49	WCB-44

tech tips from the techxperts™



60° Seat Centering Cones

- Center firmly in the valve seat
- Cones feature a .625" ID
- Steel construction
- Use the Seat Centering Cones with the Master Tool Kits (above) for proper alignment of the reamer and guide bore

Description	Jobber	Order No.	
7 Piece Kit	\$249.99	CL-6500	▼
Nominal Range			
1"	0.970"-0.730"	\$41.99	CL-6310 x
1¼"	1.230"-0.740"	41.99	CL-6308 x
1½"	1.475"-0.805"	41.99	CL-6306 x
1¾"	1.730"-0.860"	41.99	CL-6304 x
2"	1.950"-0.875"	41.99	CL-6302 x
2¼"	2.230"-1.000"	41.99	CL-6300 x
2½"	2.550"-1.875"	44.99	CL-6312 x

The centering cone must fit the valve seat properly so using the correct size is essential. This is NOT a one-size-fits-all tool. If you have a cone that is too small for the seat it could slip through the opening. If you have one that's too large, the side of the combustion chamber could interfere or you won't have enough of the cone in the seat area for it to be stable and centered.

Bronze-Liners & Tooling

Buy 3 or more sizing balls (any combination) and save 10% off jobber



Carbide Sizing Balls

- Finished to .00008" roundness
- Within the 90 Rockwell range
- The finished ID of the Bronze-Liner will be .001" smaller than the ball used

Size	Jobber	Order No.	Size	Jobber	Order No.
6.0mm	.2360" \$54.99	CL-5236	8.0mm	.3150" \$54.99	CL-5315
	.2370" 54.99	CL-5237		.3160" 54.99	CL-5316
	.2380" 54.99	CL-5238		.3170" 54.99	CL-5317
7.0mm	.2760" 54.99	CL-5276	1 1/32"	.3430" 54.99	CL-5343
	.2770" 54.99	CL-5277		.3435" 54.99	CL-53435
	.2780" 54.99	CL-5278		.3440" 54.99	CL-5344
5/16"	.3125" 54.99	CL-53125		.3445" 54.99	CL-53445
	.3130" 54.99	CL-5313		.3450" 54.99	CL-5345
	.3140" 54.99	CL-5314	3/8"	.3730" 54.99	CL-5373
				.3740" 54.99	CL-5374
				.3745" 54.99	CL-53745
				.3750" 54.99	CL-5375
				.3755" 54.99	CL-53755
				.3760" 54.99	CL-5376

tech tips
from the techxperts™

Always be sure to hold your hand under the cylinder head to catch the carbide ball as it comes out of the guide.



Removal Tool

Remove bronze liners without damaging the bore

Description	Jobber	Order No.
6.0mm	\$93.99	CL-7352
7.0mm	93.99	CL-7344
5/16"	93.99	CL-7310
8.0mm	93.99	CL-7320
1 1/32"	93.99	CL-7330
3/8"	93.99	CL-7340

Universal Driver Tool

- Fits all removal tools at left and is designed to work with your air hammer
- .401" ID • 4.75 OAL
- Order No. **CL-7333** Jobber \$45.99



Mitutoyo

Small Hole Gauge Set

- See if rebuilding or replacing is needed by checking actual guide wear
- Check guide bosses for proper interference fit during replacement
- Check and maintain correct stem-to-guide ID clearance
- 4-piece set has combined range of .125" to .500"
- With storage pouch
- Order No. **SHG-5** Jobber \$149.99



premium grade

Thin-Wall .030" Bronze-Liners

- Outlast original guides
- Dimples promotes oil retention
- Rounded nose design makes installation quick and easy
- Stripe helps you identify rounded end
- Phosphor-bronze

Phosphor-bronze liners outlast original guides and are easy to replace

Stripe helps you quickly identify the round nose end

Rounded nose design makes installation fast and easy

Dimples inside promote oil retention

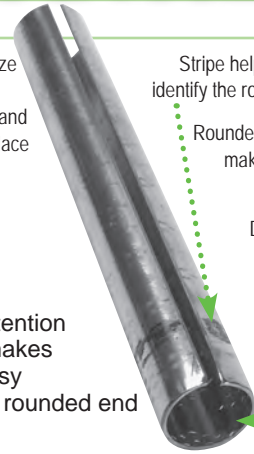

tech tips
from the techxperts™

NOTE: 5.0 & 5.5mm Guides do NOT interchange with competitors' guides. You MUST use our tooling with these guides.

Guide Size	Liner Size		Box of 16		Box of 100	
	OD	Length	Jobber	Order No.	Jobber	Order No.
5.0mm	+ .030"	2.00"	\$21.99	CL-500	\$84.99	CL-500A
5.5mm	+ .030"	2.50"	21.99	CL-550	84.99	CL-550A
6.0mm	+ .030"	2.50"	21.99	CL-600	84.99	CL-600A
7.0mm	+ .030"	2.50"	21.99	CL-700	84.99	CL-700A
.312"	+ .030"	2.50"	21.99	CL-1220	84.99	CL-1220A
8.0mm	+ .030"	2.50"	21.99	CL-1420	84.99	CL-1420A
.343"	+ .030"	3.00"	21.99	CL-1640	84.99	CL-1640A
.375"	+ .030"	3.00"	21.99	CL-1830	84.99	CL-1830A
Oversize OD Bronze Liners						
.343" +.002"	+ .032"	2.50"	\$27.99	CL-1640-2	\$109.99	CL-1640-2A
.375" +.002"	+ .032"	3.00"	29.99	CL-1820-2	129.99	CL-1820-2A
.375" +.004"	+ .032"	3.00"	29.99	CL-1820-4	129.99	CL-1820-4A

Chamfer Tool & T-Wrench

Use these optional accessories to remove any burrs that may be created when trimming the liner to length

Description	Jobber	Order No.
Chamfer Tool	\$29.99	CL-5800
T-Wrench	29.99	CL-5870

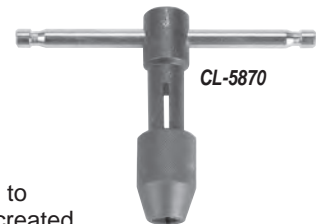

CL-5870



CL-5800

Mitutoyo

Split Ball Bore Gauge

- Dial gauge with large contact area
- Measures quickly & accurately to .0001" (.0025mm)
- Works in threaded or knurled guide IDs
- Range: .280" to .400"
- Easy to change contacts
- Includes molded plastic storage case
- Order No. **MVG-34** Jobber \$699.99



premium grade

CYLINDER HEAD REBUILDING
CLEANING, ASSEMBLY & SAFETY
SHORT BLOCK REBUILDING
FLYWHEEL GRINDING
CRANKSHAFT/ TOOLS & SUPPLIES
MISCELLANEOUS TOOLS & SUPPLIES
BRAKE SERVICE TOOLING
MEASURING TOOLS
V-TWIN & METRIC HARD PARTS



"If any of our products aren't satisfactory, we want you to send it back. We have a no hassle return policy. Just send it back, freight pre-paid within 30 days and we'll exchange it, fix it or credit your account for the amount of the purchase."

- Danielle, Goodson Customer Service, 1 year of service

CYLINDER HEAD
REBUILDING

CLEANING,
ASSEMBLY & SAFETY

SHORT BLOCK
REBUILDING

CRANKSHAFT/
FLYWHEEL GRINDING

MISCELLANEOUS
TOOLS & SUPPLIES

BRAKE SERVICE
TOOLING

MEASURING
TOOLS

V-TWIN & METRIC
HARD PARTS

Valve Seal Puller

- .810" tool dia.
- Fits Multi-Valve Engines
- Lifts from the bottom of the seal
- Works within the confines of lifter bucket bores
- Fingers grip seal for fast, easy removal
- Works on most domestic and import vehicles
- New and improved seal puller with stronger 3 jaw pulling action

Description	Jobber	Order No.
Valve Seal Puller	\$209.99	VSP-323
Replacement Shaft	54.99	VSP-323-4
Replacement O-Ring	4.49	VSP-323-5
Replacement Jaw Set (3 Pc.)	84.99	VSP-323-3
Replacement Jaw Sleeve	48.99	VSP-323-1
Black Split Sleeve	28.99	VSP-323-2

Parts are interchangeable with VSP-320



3 Finger Jaw
Grips Seals
Firmly!



made in
america

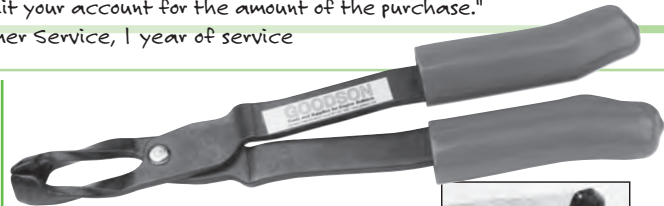

Universal Seal Pliers

- Works on OHC and in-line engines with recessed springs
- Long, serrated jaws reach into confined areas and grip seals firmly
- Heat-treated steel with easy-grip handles
- Order No. VSP-823
Jobber \$57.99



sized for
diesel

Intake & Exhaust Valve Stem Seals for 24 Valve, 7mm Cummins Diesel

- Fit 7mm valve stems
- OD measures .511"
- Sold in packs of 12

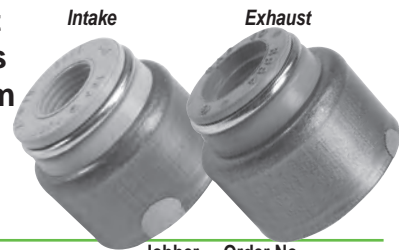

Application	Jobber	Order No.
Intake	\$14.99	CVS-59i
Exhaust	14.99	CVS-59E



QualCast

Goodson now offers the full line of QualCast Products.

Whatever you're looking for, you can find it online at www.goodson.com!

- Valves
- Valve Guides
- Valve Spring Inserts
- Valve Lifters
- Rocker Components
- Push Rods
- And a whole lot more!
- Valve Seat Inserts
- Valve Springs
- Valve Keepers (cotters, keys)
- Valve Stem Seals
- Injector Components
- Freeze Plugs

You'll find products for High Performance, Light Duty, Standard Duty and Heavy Duty. Products ship directly from QualCast's Nashville location to your door. Visit the QualCast section on the Goodson website today or Call **1-800-533-8010**.

Calibrated Test Spring

- Check Spring Tester Accuracy
- Highest-quality spring steel
- Calibrated to show pressure at a specified compressed height (includes calibration certificate)
- Order No. VST-95 Jobber \$68.99



Height Indicator

- Measure compressed spring height when testing pressure
- Ideal for high performance and checking identical springs
- For Rimac® and other spring testers
- Height Scale displays inches and metric
- Includes Dial Indicator, and Mounting Kit (additional dial indicators on page 129)
- Order No. VST-25 Jobber \$75.99

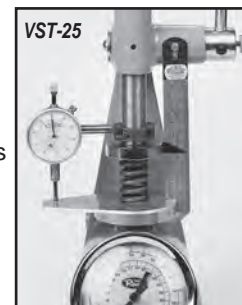



Valve Spring Testing

**Goodson
exclusive**

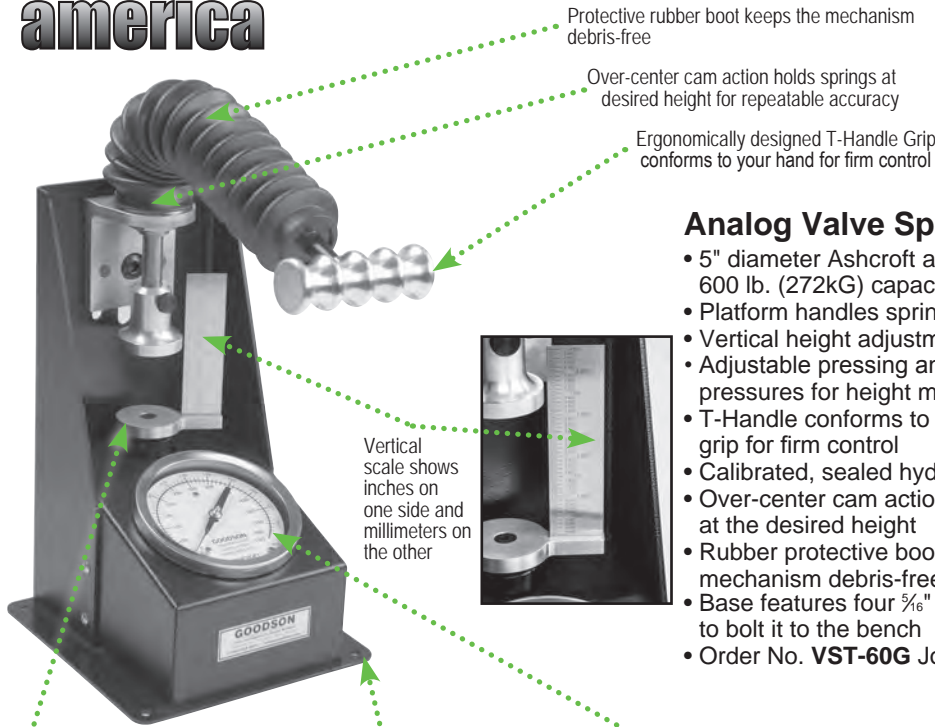

Protective rubber boot keeps the mechanism debris-free

Over-center cam action holds springs at desired height for repeatable accuracy

Ergonomically designed T-Handle Grip conforms to your hand for firm control

Vertical scale shows inches on one side and millimeters on the other



Platform handles springs up to 2" diameter and 4.5" OAL

Base includes four 5/16" holes for securely mounting the Valve Spring Tester to your bench

Easy to read 5" diameter Ashcroft-quality analog pressure gauge shows both pounds and kilograms with 600 pound capacity

Analog Valve Spring Tester

- 5" diameter Ashcroft analog pressure gauge with 600 lb. (272kG) capacity in 10 lb. (4.54kG) increments
- Platform handles springs up to 2" diameter x 4½" OAL
- Vertical height adjustments in ¾" increments
- Adjustable pressing anvil for fine-tuning open and closed pressures for height measurement
- T-Handle conforms to the operator's grip for firm control
- Calibrated, sealed hydraulic load cell
- Over-center cam action holds spring at the desired height
- Rubber protective boot keeps the mechanism debris-free
- Base features four 5/16" mounting holes to bolt it to the bench
- Order No. **VST-60G** Jobber \$799.99

TECHNICAL SPECS:

UNIT WEIGHT: 19½ lbs.

FOOTPRINT: 8½" sq.

HEIGHT: 28" with handle fully extended



Easy-to-use Travel Stop with adjustable set screws lets you set an exact position, allowing repeated testing at a desired height. Two set screws allow you to adjust for installed spring height and max lift (near coil bind).

Arbor style handle makes compressing springs fast and easy

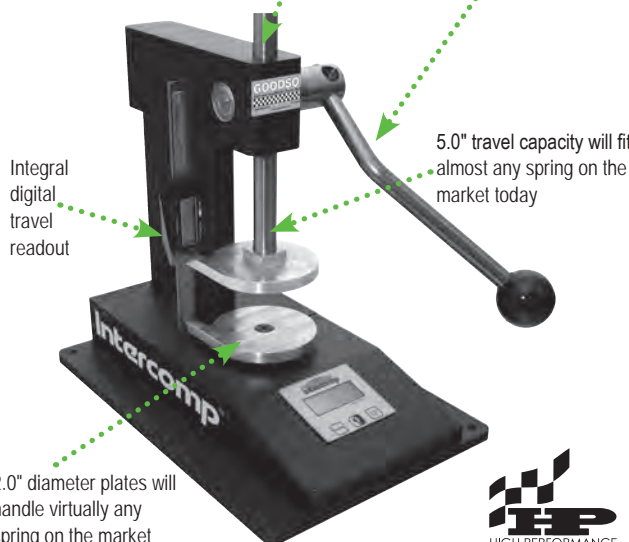

Integral digital travel readout

5.0" travel capacity will fit almost any spring on the market today

2.0" diameter plates will handle virtually any spring on the market



Protect Your Valuable Valve Spring Tester with this Cover!

- Measures 10"x14"x18"
- Same cover fits either Spring Tester
- Heavy-weight, breathable black Sun-Dura® fabric won't hold in moisture
- Order No. **GMC-VST** Jobber \$43.99

More Machine Covers on page 27

Intercomp® Digital Arbor Valve Spring Tester

- 1,500 lb / 680.4 kg load cell in 1 lb. increments
- Force units switchable from pounds to kilograms
- Billet 6061 T-6 Aluminum construction
- Digital travel readout at .001"/inch or .01/mm
- 5" travel capacity • 2.0" diameter spring pads
- Easy to read backlit screen
- Operates on 9V battery (included)
- Adjustable stop to repeatedly check springs at the same heights
- Order No. **VST-2000** Jobber \$1599.99

For routine calibration of spring testers, return tester to Goodson. Call for details, 1-800-533-8010.

CYLINDER HEAD REBUILDING
CLEANING, ASSEMBLY & SAFETY
SHORT BLOCK REBUILDING
FLYWHEEL GRINDING
CRANKSHAFT/
MISCELLANEOUS TOOLS & SUPPLIES
BRAKE SERVICE TOOLING
MEASURING TOOLS
V-TWIN & METRIC HARD PARTS

... another satisfied customer

"I am retired, still tinkering. You have preserved my account. I appreciate still having access to the parts. You are doing a great job of customer service and please continue to print a catalog."

- Wilmer Shank, Brandywine, WV, Goodson customer since 2008

CYLINDER HEAD REBUILDING



Pneumatic Head:
Adjustable to 25° in either direction for canted valves



Head Support:
Table adjusts 45° to the front and 30° to the rear



Positive Stops: Adjusts front and rear angles

CLEANING, ASSEMBLY & SAFETY



Speed Knobs:
Allows quick positioning of workpiece



Foot Pedal:
Easy, hands-free operation



Quick Release Knob:
Allows fast positioning to opposite cam bank

SHORT BLOCK REBUILDING

CRANKSHAFT/ FLYWHEEL GRINDING

MISCELLANEOUS TOOLS & SUPPLIES

BRAKE SERVICE TOOLING

MEASURING TOOLS

V-TWIN & METRIC HARD PARTS

Goodson exclusive

Slide Hammer:
A quick tap loosens keepers for fast removal

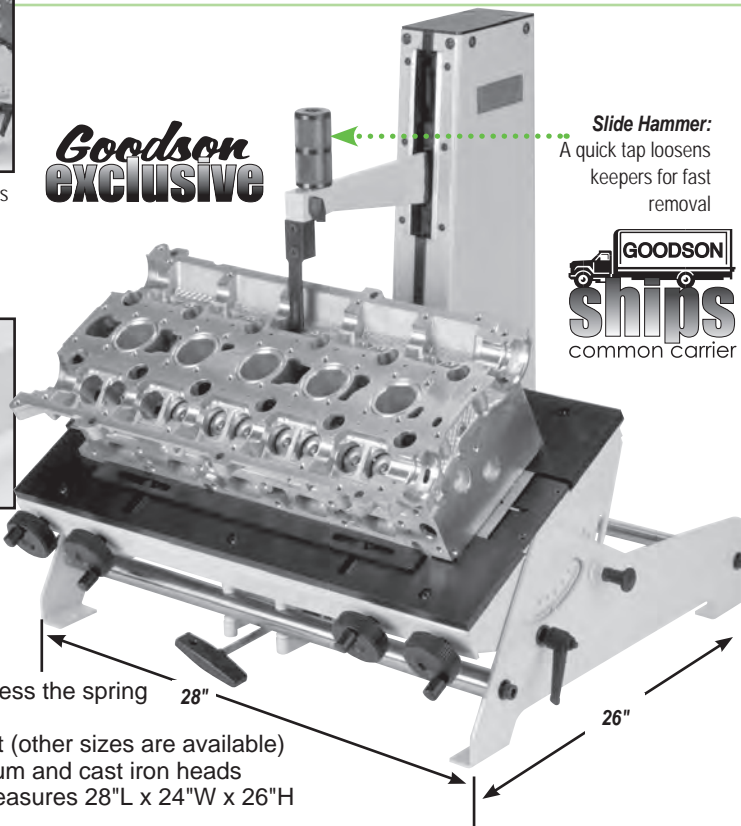

Pneumatic Valve Spring Press

- Pneumatic valve support holds valve closed as you compress the spring
- Adjustable stainless steel plate won't damage the head
- 28mm Valve Spring Adaptor (CF-502) is standard with unit (other sizes are available)
- Ideal for use on heads with recessed springs • For aluminum and cast iron heads
- Ships fully assembled • Replacement Parts Available • Measures 28"L x 24"W x 26"H
- Order No. **PSB-5000** Jobber \$5249.99

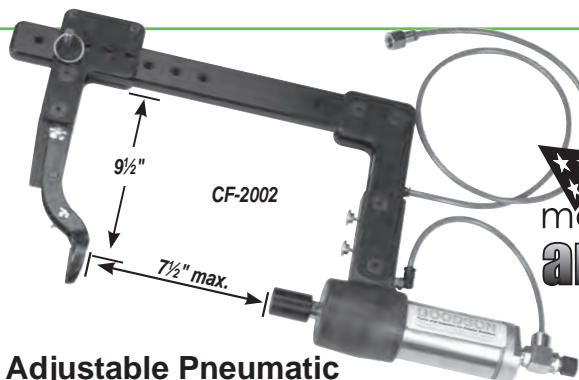

Adjustable Pneumatic Valve Spring Compressor

- Develops up to 325 lbs. of force with 130 PSI
- For springs from 3/4" to 1 3/4" dia.
- CNC-machined 6061 T6 aircraft-quality aluminum frame is adjustable in 1/4" increments
- Includes adjustable jaws (CF-44)
- Stainless steel cylinder with viton grade seals
- 2" cylinder travel • Fingertip controls • Full 1 year warranty

Description	Jobber	Order No.
Valve Spring Compressor	\$649.99	CF-2002
Replacement Parts and Accessories		
Valve Spring Adaptor Jaw Set	\$ 15.99	CF-44
1/4" Green Air Line (lin. ft.)	2.99	CF-2001-AL
Air Control Needle Valve	52.99	CF-2001-NV
Intake / Exhaust Cartridge	14.99	CF-2003-C
1/4" NPT L-Fitting	7.49	CF-2003-BCE
Air Cylinder 2" Travel	129.99	CF-2001-AC
1/8" NPT L-Fitting	5.49	CF-2003-L

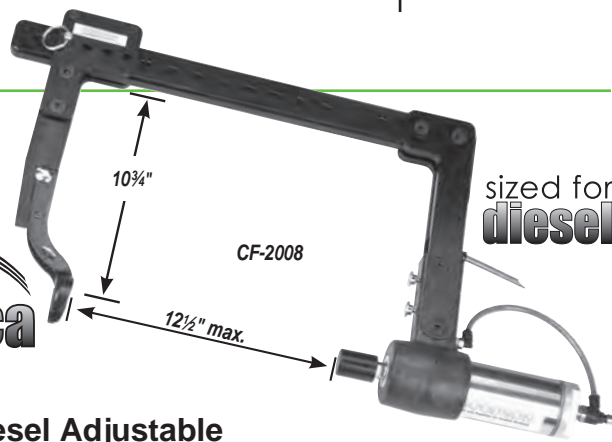

Diesel Adjustable Pneumatic Valve Spring Compressor

- Develops up to 325 lbs. of force with 130 PSI
- For springs from 3/4" to 1 3/4" dia.
- CNC-machined 6061 T6 aircraft-quality aluminum frame is adjustable in 1/4" increments
- Includes adjustable jaws (CF-44)
- Stainless steel cylinder with viton grade seals
- 2" cylinder travel • Fingertip controls • Full 1 year warranty

Description	Jobber	Order No.
Valve Spring Compressor	\$699.99	CF-2008
Replacement Parts and Accessories		
Valve Spring Adaptor Jaw Set	\$ 15.99	CF-44
1/4" Green Air Line (lin. ft.)	2.99	CF-2001-AL
Air Control Needle Valve	52.99	CF-2001-NV
Intake / Exhaust Cartridge	14.99	CF-2003-C
1/4" NPT L-Fitting	7.49	CF-2003-BCE
Air Cylinder 2" Travel	129.99	CF-2001-AC
1/8" NPT L-Fitting	5.49	CF-2003-L

made in america

Valve Spring Compressors

CYLINDER HEAD
REBUILDING

CLEANING,
ASSEMBLY & SAFETY

SHORT BLOCK
REBUILDING

CRANKSHAFT/
FLYWHEEL GRINDING

MISCELLANEOUS
TOOLS & SUPPLIES

BRAKE SERVICE
TOOLING

MEASURING
TOOLS

V-TWIN & METRIC
HARD PARTS



**Goodson
exclusive**



Locking Arm:
Holds the C-frame
securely in position
at the desired angle

Lock Collar:
Can be used to stop
vertical travel or to hold
spring compressed
while assembling
keepers

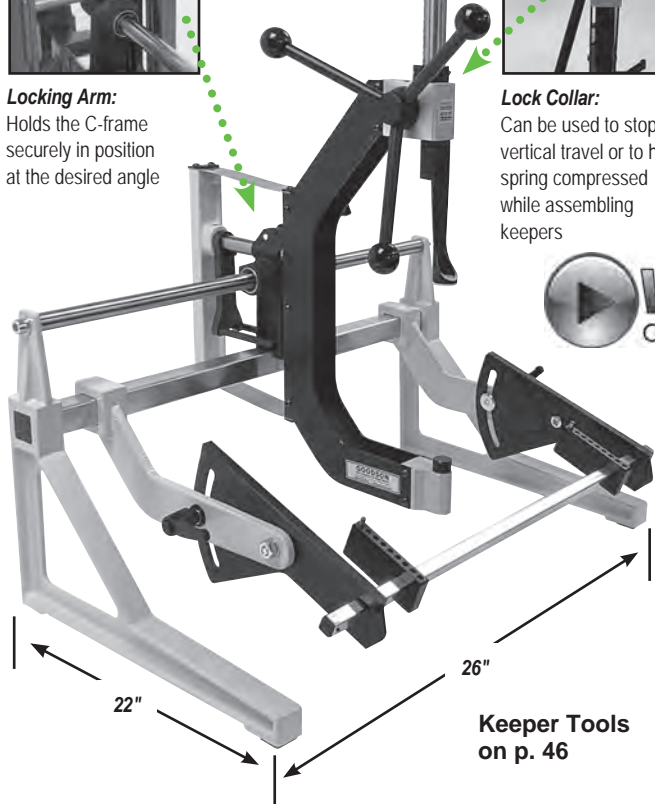

**Keeper Tools
on p. 46**

Manual Valve Spring Bench

- Remove and install valve springs on heads with recessed springs
- Includes 28mm dia. spring adaptor (CF-502), other size spring adaptors also available (see chart below)
- Frame tilts up to 25° in either direction for canted valves
- Full cylinder head support is adjustable from 0 to 45°
- Integral slide hammer easily releases stuck keepers
- Replacement parts available
- Order No. **CF-500** Jobber \$1849.99



To watch how-to use the Manual Valve Spring Bench, scan the code at right with the camera on your smart phone or other smart device.

Spring Adaptors

- Fit both manual (CF-500) and pneumatic (PSB-5000) spring benches
- 1/2" pin diameter
- Solid steel construction with replaceable nylon wear insert



Description	Reach	Jobber	Adaptor	Jobber	Insert
18mm	4 1/2"	\$279.99	CF-518	\$23.99	CF-518-1
23mm	4 1/2"	279.99	CF-501	23.99	CF-501-1
28mm	3 1/2"	279.99	CF-502	23.99	CF-502-1
35mm	2 1/2"	279.99	CF-503		insert not required



**made in
america**

1000 Lb. Pneumatic Valve Spring Compressor

- Lightweight — built of 6061 / 7075 T-6 Aluminum
- 1 1/2" Screw Adjustment — 7" to 8 1/2" Throat
- Certified to 1000 lbs of force
- Two stage air pump develops up to 1000 lbs. of force on as little as 70 psi air supply — **Do NOT exceed 120 psi**
- Includes 1.600" ID Jaw adaptor, 1.740" ID jaw sold separately

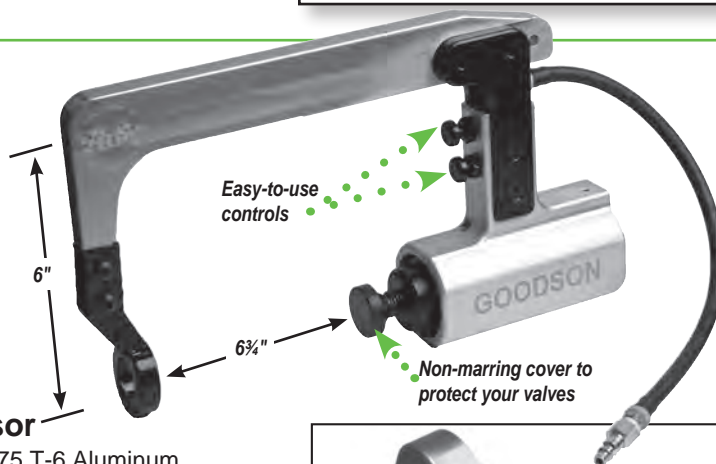

Easy-to-use controls

Non-marring cover to protect your valves

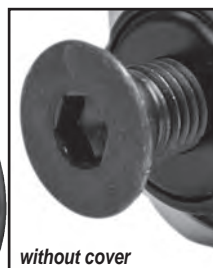

Description	Jobber	Order No
Spring Compressor with 1.600" ID Jaw	\$999.99	GSC-1000
Replacement Standard Jaw, 1.600" ID	137.99	GSC-3002
Adaptor Jaw, 1.740" ID	137.99	GSC-3003
LS1 Jaw Adaptor (1.740 OD) use with CF-3002	41.99	GSC-3000-LS1
Rebuild Seal Kit (with Intake Button Return Spring)	114.99	GSC-3000SK
Replacement Intake Button Return Spring	67.99	GSC-3004
Intake Trigger Assembly	69.99	GSC-20004A
Exhaust Trigger Assembly	64.99	GSC-20004B
Delrin Pressure Cap (included)	21.99	B-10005C

NOT interchangeable with our CF-3000B Spring Compressor

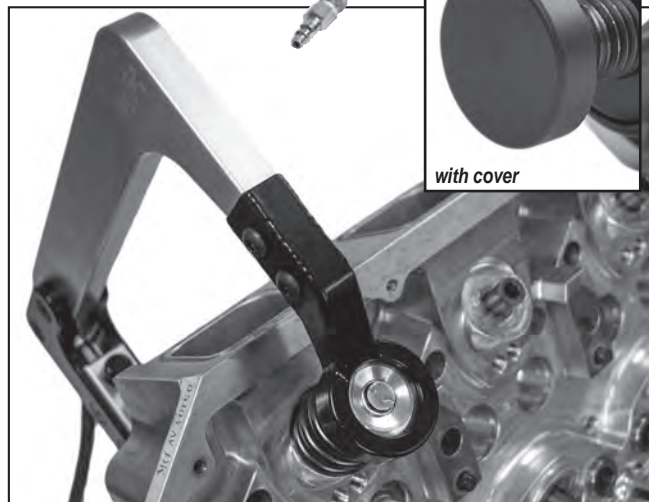



"You'll always get fast, reliable service from Goodson, even on international orders. We'll do whatever it takes to make sure you get your shop supplies as quickly and easily as possible - anywhere in the world."

- Kim, Goodson Export Sales Manager, 39 years of service

CYLINDER HEAD
REBUILDING

CLEANING,
ASSEMBLY & SAFETY

SHORT BLOCK
REBUILDING

CRANKSHAFT/
FLYWHEEL GRINDING

MISCELLANEOUS
TOOLS & SUPPLIES

BRAKE SERVICE
TOOLING

MEASURING
TOOLS

V-TWIN & METRIC
HARD PARTS

Manual Valve Spring Compressor

- Weighs only 6 lbs
- High leverage allows for easy, one-hand operation
- Covers a range from 10"H to 8"D
- Works with most L-head and valve-in-head engines
- Fits truck & tractor engines
- Jaws adjust for different spring sizes

Description	Jobber	Order No.
Spring Compressor	\$99.99	CF-140
Replacement Jaw Set	15.99	CF-44
HD Replacement Jaw Set	36.99	CF-44HD

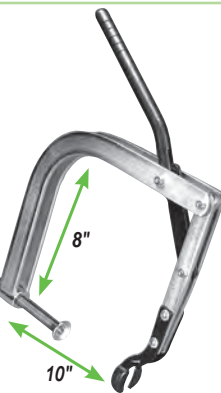

Manual Valve Spring Compressors

- Handle valve springs from a range of applications
- Welded, gusseted all-steel construction takes plenty of abuse
- Plenty of leverage to compress valve springs
- Order No. **CF-1500** Jobber \$279.99

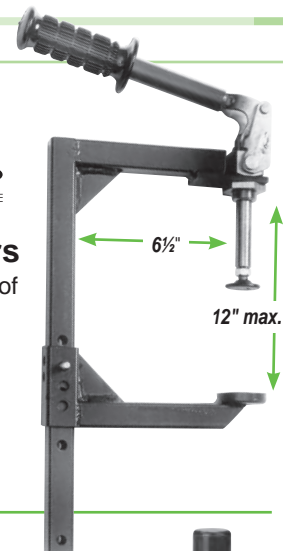

small engine powersports

Manual Valve Spring Compressor For Small Engines

- Steel construction
- 20# max. spring pressure
- Once you lock the compressor in position, your hands are free to work
- Includes 2 jaw sets - small, for springs up to 7/8" (22.2mm) and large, for springs up to 1 1/16" 27.0mm)
- Order No. **CF-600** Jobber \$29.99

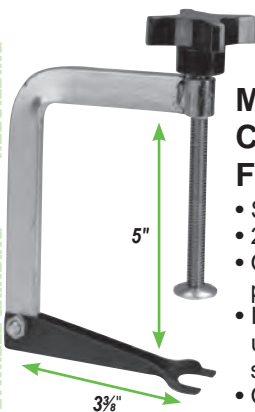

Valve Spring Compressor Adaptor

- Fit seat and guide machines or drill press
- Puts collet or drill press chuck behind adaptor
- Allows more room to remove or re-install valve keepers and associated components
- Fits 1/2" collet or Jacobs chuck (not included)

OD (mm)	Reach (mm)	Jobber	Order No.
3/4" (19.1)	3 3/4" (95.3)	\$47.99	CF-6
1 3/16" (20.6)	3 3/4" (95.3)	47.99	CF-8
1" (25.4)	3 3/4" (95.3)	47.99	CF-10
1 1/4" (31.7)	3 3/4" (95.3)	50.99	CF-12
1 1/2" (38.1)	3 3/4" (95.3)	50.99	CF-15



Keeper Installation Tools

- Spring-loaded plunger
- For single & multi-groove keepers
- Reaches keeper grooves located farther from the valve tip • Ideal for use with **CF-500** (p. 45) and **PSB-5000** (p. 44)

Best Keeper Tool on the Market!

Size	Jobber	Order No.
5mm / .2031"	\$95.99	VKI-5
6mm / .2344"	95.99	VKI-6
7mm / .2812"	95.99	VKI-7
8mm / .3125"	95.99	VKI-8
Replacement Rubber Sleeve	7.49	VKI-56

Adaptors for Deeply Recessed Springs

- Open top design gives easy access to keepers
- Durable, non-marring material
- Fit on Split-Jaw Spring Adaptors such as our **CF-44** (below)

Description	OD	Height	Jobber	Order No.
Small Metal Adaptor	26mm	4" (101.6mm)	\$32.99	CF-32
Medium Nylon Adaptor	27mm	3" (76.2mm)	32.99	CF-24-G
Large Nylon Adaptor	32mm	3" (76.2mm)	32.99	CF-25-G



One of the handiest keeper tools you'll ever find!

Keeper Magnet

- 6 5/16" long holder fits easily into deep bores
- Powerful .170" diameter earth magnet holds keepers securely when removing or installing
- Order No. **VKM-17** Jobber \$18.49

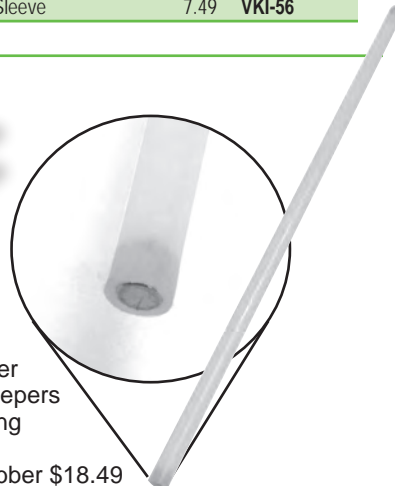

Valve Spring Adaptor Jaws

- Fit frames with double locking screws to secure jaws such as Goodson **CF-2002**, **CF-2004**, **CF-2008** and **CF-140** • Heavy duty jaws are non-adjustable (Has a 1 5/8" max spring diameter)

Description	Jobber	Order No.
Standard Duty 1.000"-1.875" (25.4-47.6mm) Range	\$15.99	CF-44
Heavy Duty (non-adjustable)	36.99	CF-44HD

Air Powered Grinder
uses standard shop air

DESIGNED BY AN ENGINE BUILDER FOR ENGINE BUILDERS!

Bucket Lifter Grinder Assembly with FREE Grinder

- Machine just the bucket lifter!
- Fast and accurate
- Save time — measure once, then remove the material from inside the Bucket Lifter instead of machining the stem height and finding the right VAD thickness or grinding the seat to meet your specs
- Micrometer feed shows how much material is being removed
- Confirm with dial indicator and bridge (included)
- Use right at your assembly station
- Works with most Bucket Style Lifters, including those with VADs
- Complete Assembly includes Air Driver, CBN Cutter, Micrometer Feed Body, Dial Indicator and Indicator Base
- **US Patent Number US 10456887**

Description	Jobber	Order No.
Complete Bucket Lifter Grinder Assembly	\$849.99	BLG-1000
Replacement CBN Cutter	86.99	BLG-1001
Replacement Dial Indicator	31.99	EDI-1

Micrometer Feed shows
how much material you are
removing

CBN Cutter makes
quick work of
virtually any
bucket lifter

Use the Dial Indicator and Base
to measure the valve contact point.
Once determined, remove necessary
material to set lash.

 **video**
available

View our Tech Lab Tuesday
video to see how easily you can
adjust valve lash by machining
the bucket lifters with the Bucket
Lifter Grinder. Scan the code
at left with the camera on your
smart phone or other smart
device for instant access.

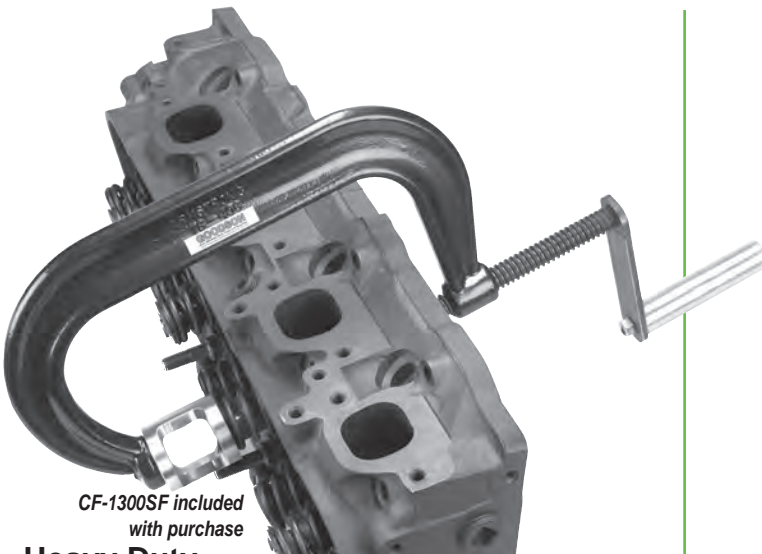

CF-1300SF included
with purchase

Heavy Duty Manual Valve Spring Compressor

- Drop forged steel frame
- Open receiver design allows for quick access to keepers
- Accommodates springs up to 1³/₄" diameter
- 8¹/₂" throat • 6" deep
- Compresses springs up to 1000 pounds

Description	Jobber	Order No.
Manual Valve Spring Compressor	\$369.99	CF-1300
Small Receiver (OD: 1.625", ID: 1", Height: 2.156")	86.99	CF-1300SF
Large Receiver (OD: 2.0", ID: 1.197", Height: 2.25")	98.99	CF-1300LF

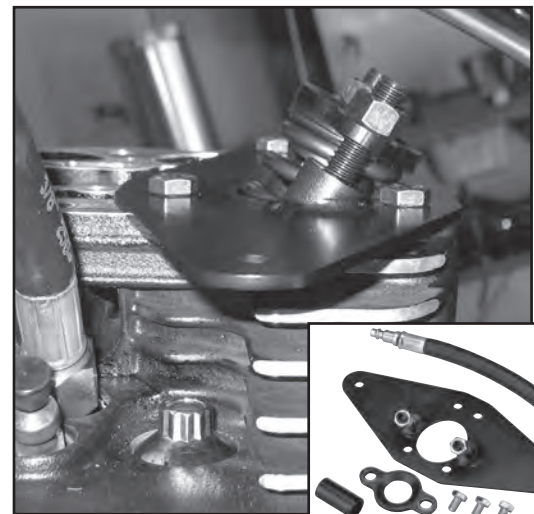

V-Twin On-the-Engine Valve Spring Compressor

Replace broken valve springs, install high performance valve springs, remove and replace valve guide seals all without disassembling the bike. Just remove the gas tank and get to work. Use on Sportster, Evolution, Twin-Cam and most aftermarket V-Twins. Kit includes valve spring compressor, adaptor for compressing beehive springs, valve seal driver/installer and head pressurizing hose. Order No. **CF-HDIF** Jobber \$179.99

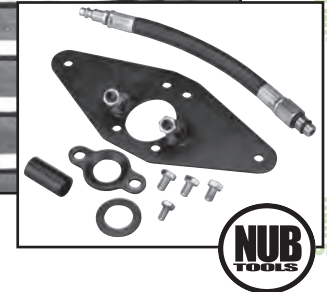

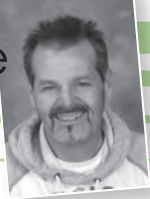

"We work hard to get the right products in the right boxes and ship them to the right address every single time."

- Shawn, Goodson Shipping, 4 years of service

CYLINDER HEAD
REBUILDING

CLEANING,
ASSEMBLY & SAFETY

SHORT BLOCK
REBUILDING

CRANKSHAFT/
FLYWHEEL GRINDING

MISCELLANEOUS
TOOLS & SUPPLIES

BRAKE SERVICE
TOOLING

MEASURING
TOOLS

V-TWIN & METRIC
HARD PARTS

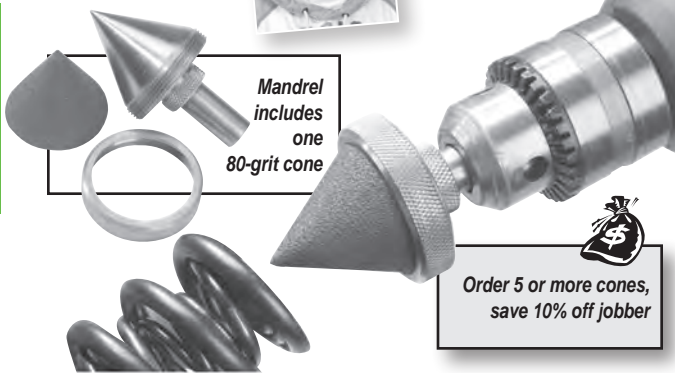

Mandrel
includes
one
80-grit cone

Order 5 or more cones,
save 10% off jobber

Small Chamfering Cones & Mandrels Make Deburring and Chamfering Easy In Tight Spaces

These mandrels are available in two diameters – 3/4" and 1 1/2" diameters with a 1/2" shank to fit most portable drills. The small diameter fits easily into tight spaces such as Beehive Valve Springs (see page 134) or bolt holes. The mandrel is designed to support a 60° abrasive cone which is held securely by the retaining ring. One 80-grit cone is included with initial purchase.

Description	Jobber 1+	Jobber 5+	Order No.
3/4" Dia. Mandrel	\$69.99		CC-34
3/4" Dia. Abrasive Cones	80 grit	4.39	\$3.95 CC-35
	120 grit	4.39	3.95 CC-36
1 1/2" Dia. Mandrel	\$69.99		CC-60
1 1/2" Dia. Abrasive Cones	80 grit	5.39	\$4.85 CC-61
	120 grit	5.39	4.85 CC-62

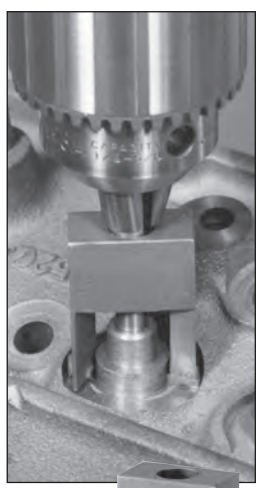

3-D Fast Cut™
Adjustable Spring Pad
Cutters on page 14



Valve Spring Seat Cutters

- Resize valve spring seats to maintain spring-to-valve concentricity or use to enlarge seats for over-size dual springs
- Requires special pilot – see chart below

Carbide Tipped Cutter Bodies (use VP pilots below)

OD	ID	Jobber	Order No.
1.320"	.630"	\$107.99	VSS-1320
1.350"	.625"	107.99	VSS-1350
1.500"	.625"	107.99	VSS-1500
1.550"	.625"	107.99	VSS-1550
1.625"	.625"	107.99	VSS-1625
1.680"	.750"	107.99	VSS-1680HD
1.750"	.625"	107.99	VSS-1750

Hardened & Ground Pilots

Guide ID	Jobber	Order No.
.275"	7.0	\$37.99 VP-7MM
.312"	7.9	37.99 VP-312
.343"	8.7	37.99 VP-343
.375"	9.5	37.99 VP-375

tech tips

from the techxperts™
You must use these pilots with the VSS and VSC cutters. The flat sides are necessary for a proper fit.

Universal Gel Lube

- Sprays on as a liquid and forms into a gel within seconds
- Penetrating formula blends freely with motor oil
- Multiple uses, including cams, lifters, rocker arms, bearings, pistons/wrist pins, cylinders, etc.
- Provides lubrication for engines subjected to prolonged storage before initial start-up
- Aerosol*
- Order No. **GL-8U**

Jobber 1+ \$21.99 ea., Jobber 6+ \$19.79 ea.

*Hazardous Goods Fees Will Apply if Shipped By Air



8 Piece Valve Train Checking Spring Set

- 1.250" OD
- Spring Steel construction
- Essential for high-performance engine building and engine blueprinting
- Maintain a positive valve train position while checking valve to piston clearance
- Order No. **VTS-8** Jobber \$34.99



Buy the
Kit and
SAVE!

Dial Indicated Valve Stem Height Gauges

- 5 sizes to choose from
- Small diameter extended measuring body allows extra height for dial indicator clearance
- Use with our large-faced Dial Indicator to check valve tip height



Description	Jobber	Order No.	Incl.		
Valve Stem Height Gauge Kit w/Stand	\$249.99	VSH-KIT	▼		
Dial Indicator (2" travel, .001" graduations)	78.99	MDI-2	x		
Dial Indicator (1" travel, .001" graduations)	31.99	EDI-1			
Measuring Bodies					
	OD	ID	OAL		
	.750"	.625"	3.830"	\$42.99 VSH-205	x
	.900"	.770"	2.840"	42.99 VSH-203	x
	.900"	.770"	3.840"	42.99 VSH-204	x
	1.060"	.812"	2.840"	42.99 VSH-201	x
	1.250"	1.090"	3.300"	42.99 VSH-202	x
Tool Stand				53.99 TS-5	x
1" Checking Standard				12.99 MCS-1	

More dial indicators on page 129

Non-Serrated Valve Spring Booster Shims

- Won't compress
 - Shims meet or exceed OE specifications
 - Maintain pressure and protect head from spring abrasion
 - Made of prime quality cold rolled steel
 - Support valve springs better than serrated shims
 - Won't damage spring pad area on aluminum heads or cause lateral loads or harmonics
- Special Orders are available.**

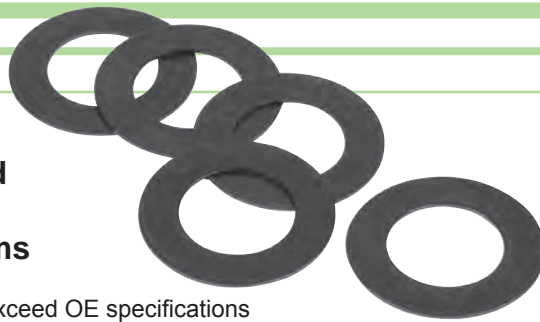

Order 5 or More Packs, SAVE 10% off jobber

Size		50 count High Performance			100 count		
OD	ID	.060"	.030"	.015"	.060"	.030"	.015"
1.000"	0.688"				A-101	B-101	C-101
	0.765"			A-104	B-104		
1.100"	0.719"					B-106	
1.218"	0.875"				A-105	B-105	
1.250"	0.625"	A-107-HP	B-107-HP	C-107-HP	A-107	B-107	C-107
	0.812"	A-203-HP	B-203-HP	C-203-HP	A-203	B-203	C-203
	0.875"				A-201	B-201	
1.360"	1.000"	A-102-HP	B-102-HP	C-102-HP	A-102	B-102	
1.375"	0.765"	A-301-HP	B-301-HP	C-301-HP		B-301	
1.438"	0.645"	A-306-HP	B-306-HP	C-306-HP			
1.439"	0.765"	A-305-HP	B-305-HP	C-305-HP			
1.480"	0.703"	A-303-HP	B-303-HP	C-303-HP	A-303	B-303	
1.500"	0.645"	A-306S-HP	B-306S-HP	C-306S-HP			
	1.031"	A-103-HP	B-103-HP	C-103-HP	A-103	B-103	
1.634"	0.643"	A-601-HP	B-601-HP	C-601-HP			
Jobber		\$23.99	\$23.99	\$23.99	\$23.99	\$23.99	\$23.99



Magnetic Head Bolt Washer & Valve Spring Shim Removal Tools

- Hollow design allows easy access over studs or head castings
- Powerful earth magnets grab firmly, letting you lift the washer or shim easily

Description	Jobber	Order No.	Incl.
Magnetic Remover Set	\$129.99	MWR-SET	▼
Washer Removers	ID	OD	
	0.250"	0.625"	37.99 MWR-14 x
	0.500"	0.865"	37.99 MWR-12 x
	0.450"	0.812"	37.99 MWR-716 x
Shim Remover	0.708"	1.355"	41.99 MVR-2 x

No More Guesswork... Measure CCs Accurately!

Cylinder Head CC-ing Equipment

- Use glass buret with alcohol or solvent
- Positive on/off fluid control valve
- Clear acrylic plate lets you see when the combustion chamber is full
- Mix Measuring Concentrate with water to make 1 gallon

Description	Jobber	Order No.	Incl.
CC-Measurement Kit	\$184.99	CCB-KIT	▼
100cc Glass Buret	107.99	CCB-100	x
5" x 5" x 3/8" Acrylic Plate	15.99	GCB-3	x
Buret Cleaning Brush - 35 1/2" OAL	10.99	GCB-BRUSH	x
Buret Stand	20.99	GCB-1	x
Buret Clamp	20.99	GCB-2	x
Funnel	11.99	CCB-FUNNEL	x
Blue Measuring Liquid Concentrate (Yields 1 Gal.)	17.99	GCB-LIQUID	
4" Precision Cylinder Head Level	194.99	LEV-4	
Replacement Vial for 4" level	161.99	VGL-101	
100cc Glass Beaker	43.99	GC-100	
Universal Cylinder Head Holders (pair)	159.99	HH-200	



100cc Glass Buret allows use with alcohol or solvent with high-visibility red markings

Clamp gives you ability to fully adjust the height of the buret in relation to your cylinder head

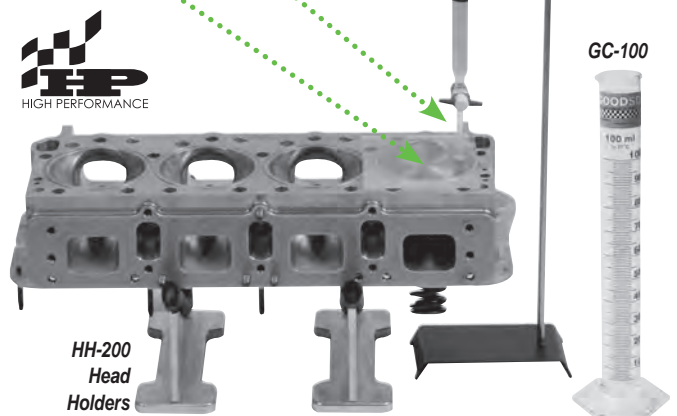

CYLINDER HEAD REBUILDING
CLEANING, ASSEMBLY & SAFETY
SHORT BLOCK REBUILDING
FLYWHEEL GRINDING
CRANKSHAFT/ TOOLS & SUPPLIES
MISCELLANEOUS
BRAKE SERVICE TOOLING
MEASURING TOOLS
V-TWIN & METRIC HARD PARTS



"Goodson accepts major credit cards, debit cards, bank drafts and personal checks. Call us for more information."
- Bev, Goodson Accounting Manager - 39 years of service

resharpening available

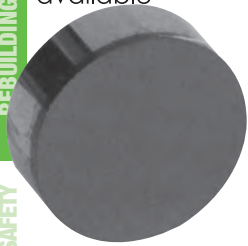

PCD Inserts for Aluminum

- A must for shops committed to meeting today's strict surface finish requirements
- Fits machines with 3/8" & 1/2" CBN holder
- 1/2" diameter inserts require shim*
- Use with Resurfacing Spray (HPS-16) for best results (below)

Titanium-Nitride Coated			Goodson		Radiac	
Dia.	Thick.	Sided	Jobber	Order No.	Jobber	Order No.
3/8"	1/8"	Single	\$199.99	PCDS-375	---	---
	1/8"	Single	91.99	GPCD-375	---	---
1/2"	1/8"	Single	---	---	\$259.99	2379264*
	1/8"	Single	97.99	GPCD-500*	---	---
1/2"	3/16"	Single	209.99	PCDS-500	---	---
1/2"	3/16"	Single	---	---	259.99	2379265
1/2"	3/16"	Single w/screw hole	---	---	157.99	2X6145
1/16"	Thick Carbide Shim*		24.99	CBN-500SHIM	---	---

tech tips Always cut with the dull finished side of the insert
from the techexperts™

CBN Cutter Inserts for Cast Iron

- Faster and cleaner than segments and wheels

Uncoated			Goodson		Uncoated Radiac	
Dia.	Thick.	Sided	Jobber	Order No.	Jobber	Order No.
3/8"	1/8"	Single	\$134.99	GCBN-375	---	---
	1/8"	Single	144.99	GCBN-500*	---	---
1/2"	1/8"	Double	254.99	CBN-500D*	\$247.99	2X5299*
	3/16"	Single	279.99	CBN-500S	251.99	2359233
3/16"	Solid		---	---	314.99	2359234
3/16"	Single Sided with Screw Hole		---	---	164.99	2X6144
3/16"	Special Edge Prep for Diesel		---	---	238.99	2379268

Titanium-Nitride Coated			Goodson		Radiac	
Dia.	Thick.	Sided	Jobber	Order No.	Jobber	Order No.
3/8"	1/8"	Double	\$199.99	CBN-375D	---	---
	1/8"	Single	179.99	CBN-375S	---	---

Sharp Uncoated			Goodson		Radiac	
Dia.	Thick.	Sided	Jobber	Order No.	Jobber	Order No.
3/8"	1/8"	Single	\$159.99	CBNS-38	---	---
1/2"	3/16"	Single	189.99	CBNS-12	---	---
1/16"	Thick Carbide Shim*		24.99	CBN-500SHIM	---	---

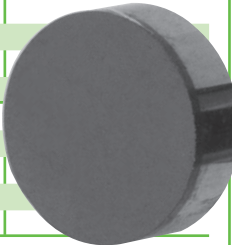

Cut using the dull finished side

resharpening available

CBN Super Abrasive For Cast Iron Diesel Heads

- Designed for cast diesel heads with hardened pre-cups • Won't chip
- Fits all overhead surfacers with 1/2" diameter insert capacity
- Will NOT work on standard cast heads

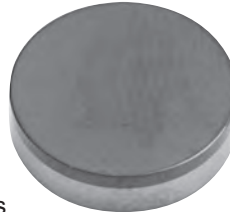

Standard Grade Cutters				
Dia.	Thick.	Sided	Jobber	Order No.
3/8"	1/8"	Single	\$139.99	GCBN-D375
1/2"	1/8"	Single	149.99	GCBN-D500

Premium Grade Cutters				
Dia.	Thick.	Sided	Jobber	Order No.
1/2"	1/8"	Single	\$399.99	DRD-500
1/16"	Thick Carbide Shim		24.99	CBN-500SHIM

*NOTE: A 1/16" thick carbide shim must be used on DCM machines

Measure here for replacement vial

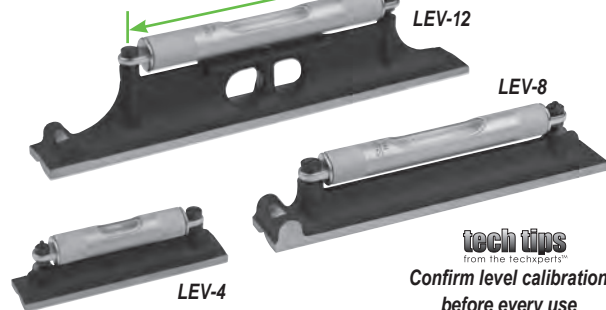

Starrett Precision Levels & Vials

- Graduated vials with satin-chromed, brass protective covers that rotate to close tightly
- Base castings are seasoned, then precision machined and finished on a bearing surface • Replaceable vials
- Adjustable for precise calibration
- 1 division equals .0005" per inch
- Fits pilots from 6mm to .437"

tech tips from the techexperts™
Confirm level calibration before every use

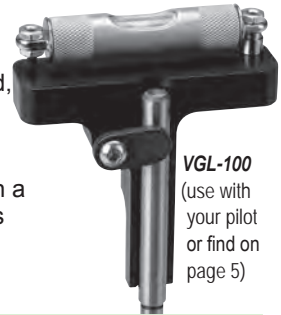

VGL-100 (use with your pilot or find on page 5)

Description	Jobber	Order No.	Replacement Vial	
4" Valve Guide Level (3" vial)	\$294.99	VGL-100	\$161.99	VGL-101
4" Level (3" vial - nominal)	194.99	LEV-4	161.99	VGL-101
8" Level (6" vial - nominal)	289.99	LEV-8	172.99	LEV-8-1
12" Level (8" vial - nominal)	429.99	LEV-12	215.99	LEV-12-1

See goodson.com for level calibration instructions

Order 6 or more cans, Save 10% off Jobber

High Performance Resurfacing Spray

- Prolongs cutter life
- Enhances surface finish
- Refreshing scent
- 11 oz. Aerosol* can
- Order No. HPS-16
- Jobber 1+ \$15.99 ea.
- Jobber 6+ \$14.39 ea.

*Hazardous Goods Fees Apply When Shipped By Air



Resharpening: \$9.00 per bit

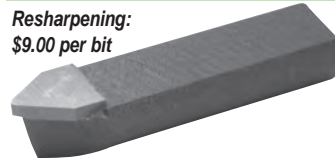

Enlarged for clarity

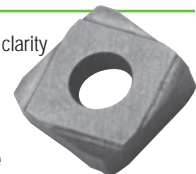

Tool Bits For Van Norman 530, 570 Rotary Broaches

- Can be resharpened
- Order No. VN-65C
- Jobber 1+ \$29.99 ea.
- Jobber 8+ \$26.99 ea.



Carbide Cutter Replacement Tips For Storm Vulcan Broach Style Surfacer

- Fits Storm Mill 85, 85B, 85BE, 85C, 85N and 880
- Order No. SV-85BE
- Jobber \$34.99



Cylinder Head Resurfacing

Abrasive Industrial Supplies

Need a Different Size or Grit or Material?

We can make the size you need. Specify grit, grain and size and we'll take it from there. Call 1-800-533-8010 for info!

Cylinder Head Resurfacing Belts

A belt has three important parts: abrasive, bond and backing. Goodson belts are made for top performance and long life. Our belts also feature a unique splice that permits use in both directions for even longer wear; when worn one way, turn belt around to resurface more heads.

Abrasive: Match the abrasive to the workpiece (aluminum, cast iron or steel) and to your machine for the longest belt life.

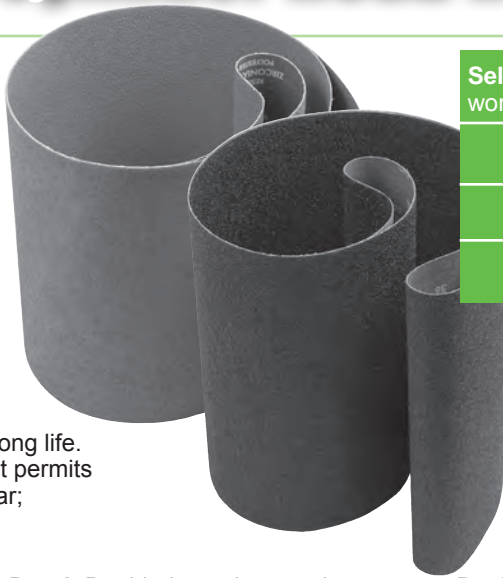

Selection Guide: which abrasive works best on what materials...

ALUMINUM	CAST IRON	STEEL	Zirconia-Alumina (40g)
			Silicon-Carbide (40g)
			Silicon-Carbide (80g)



Buy 3 or 4 belts, save 10% off jobber
Buy 5 or more, save 15% off jobber

Bond: Double-layer, heat-resistant resin holds abrasive firmly. Bond is so strong that grains wear out instead of loosening.

Backing: Waterproof, poly-back belt won't tear or fray. It's the toughest backing of any resurfacing belt.

See list of machines and belt sizes below to determine which belt(s) you need.

Silicon-Carbide 40-grit:

- Good-quality • Black
- Primarily for cast iron but can resurface aluminum if extra care is used
- Down-pressure optional

Silicon-Carbide 60-grit:

- Good-quality • Black
- Primarily for cast iron but can resurface aluminum if extra care is used
- Down-pressure optional

made to order

Silicon-Carbide 80-grit:

- Good-quality • Black
- Designed especially to resurface aluminum
- Down-pressure not recommended

Zirconia-Alumina 40-grit:

- Better-quality
- Blue
- Grains fracture under pressure to stay sharp
- For cast iron or steel
- Down-pressure recommended

Zirconia Alumina With Grind Aid - 40-grit:

- Premium-quality belt with pre-applied Grind Aid • Blue/Green
- Excels on severe applications
- Grains fracture under pressure to stay sharp
- For stainless steel, alloy
- Down-pressure required

Belt Size	Jobber	Order No.	Jobber	Order No.	Jobber	Order No.	Jobber	Order No.	Jobber	Order No.
10" x 87"	\$38.99	SGS-10-87	\$36.99	SGS-10-87-60	\$33.99	SGA-10-87	\$37.99	SGB-10-87	\$54.99	SGZ-10-87
10" x 103"	42.99	SGS-10-103	43.99	SGS-10-103-60	39.99	SGA-10-103	49.99	SGB-10-103	59.99	SGZ-10-103
11 1/8" x 76"	34.99	SGS-11-76	34.99	SGS-11-76-60	33.99	SGA-11-76	41.99	SGB-11-76	52.99	SGZ-11-76
11 1/8" x 79"	37.99	SGS-11-79	36.99	SGS-11-79-60	35.99	SGA-11-79	44.99	SGB-11-79	54.99	SGZ-11-79
11 1/8" x 89"	41.99	SGS-11-89	39.99	SGS-11-89-60	38.99	SGA-11-89	47.99	SGB-11-89	58.99	SGZ-11-89
11 1/8" x 91"	41.99	SGS-11-91	39.99	SGS-11-91-60	38.99	SGA-11-91	48.99	SGB-11-91	62.99	SGZ-11-91
11 1/8" x 101"	44.99	SGS-11-101	41.99	SGS-11-101-60	41.99	SGA-11-101	54.99	SGB-11-101	64.99	SGZ-11-101
14" x 86"	45.99	SGS-14-86	45.99	SGS-14-86-60	43.99	SGA-14-86	56.99	SGB-14-86	67.99	SGZ-14-86
14" x 103"	52.99	SGS-14-103	49.99	SGS-14-103-60	48.99	SGA-14-103	69.99	SGB-14-103	74.99	SGZ-14-103
14" x 107 1/2"	54.99	SGS-14-107	53.99	SGS-14-107-60	52.99	SGA-14-107	74.99	SGB-14-107	79.99	SGZ-14-107
14" x 113 1/2"	59.99	SGS-14-113	58.99	SGS-14-113-60	57.99	SGA-14-113	79.99	SGB-14-113	81.99	SGZ-14-113
15" x 127 1/2"	64.99	SGS-15-127	81.99	SGS-15-127-60	63.99	SGA-15-127	81.99	SGB-15-127	89.99	SGZ-15-127

Colors may vary due to manufacturing process. Guaranteed for 1 year from original purchase date.

Belt/Machine Compatibility **tech tips**

Belt Size	Machine(s)
10" x 87"	Rogers SB-1028, SF-1028, T&S Machine, Master Tool 1029
10" x 103"	Rogers SF-1036, T&S Machine, Master Tool PS1036
11 1/8" x 76"	Winona Van Norman BG-600
11 1/8" x 79"	RMC, Peterson RG-1203
11 1/8" x 89"	RMC-800, Serv-Equip PG-1229
11 1/8" x 91"	Peterson RG-1234, Kansas Instruments
14" x 86"	Automotive Craftsman
14" x 103"	Master Tool
14" x 107"	Kwik-Way 870 Master Surfer
14" x 113 1/2"	Storm Vulcan/Anderson AB-1000A, Peterson PG-1400
15" x 127 1/2"	Storm Vulcan/Anderson AB-1540A, Anderson AB-1560, IDL HS-4350, Peterson PG-1500, Winona Van Norman BR-1500, BG-1515 & BG-1520



Semi-Synthetic Belt Resurfacer Coolant

- Rust-inhibiting
- For ALL belt resurfacers with a coolant sump
- Dilute 30 parts water to 1 part coolant

Size	Jobber	Order No.
1 Gallon (3.79L)	\$ 47.99	SGB-10
5 Gallons (18.39L)	229.99	SGB-50

CYLINDER HEAD REBUILDING
CLEANING, ASSEMBLY & SAFETY
SHORT BLOCK REBUILDING
CRANKSHAFT/ FLYWHEEL GRINDING
MISCELLANEOUS TOOLS & SUPPLIES
BRAKE SERVICE TOOLING
MEASURING TOOLS
V-TWIN & METRIC HARD PARTS



"We are committed to maintaining your privacy. Information about you and your business is never sold, rented or given to anyone outside of our company."

- Sue, Goodson Office Manager - 37 years of service

CYLINDER HEAD
REBUILDING

CLEANING,
ASSEMBLY & SAFETY

SHORT BLOCK
REBUILDING

CRANKSHAFT/
FLYWHEEL GRINDING

MISCELLANEOUS
TOOLS & SUPPLIES

BRAKE SERVICE
TOOLING

MEASURING
TOOLS

V-TWIN & METRIC
HARD PARTS

SAVE!

Buy a complete set of 8 or more segments and take 10% off jobber!



tech tips

from the techxperts™

4 Keys to Resurfacing Aluminum Heads

1 - Choose the correct abrasive

Use a speckled wheel segment to grind aluminum heads.

2 - Lubricate, Lubricate, Lubricate

Put a light coat of **Grind Aid (GRA-10)** on the abrasive to reduce aluminum build up. Speed up the travers and reduce the cut to .0005" to .0010" per pass.

3 - Dress for Success

Keep grains open by dressing often. Don't dress before the last pass, but be sure to apply Grind Aid liberally so the stone yields a finer surface finish.

4 - Keep heat build-up to a minimum

The greatest danger is heat build up that can cause scoring as aluminum transfers to the stone. Take shallow cuts and use plenty of lubrication to prevent this.

Silicon-Carbide
Abrasive



Silicon-Carbide
Abrasive



Aluminum Oxide &
Silicon-Carbide
Abrasive

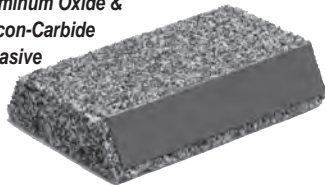

Aluminum
Oxide
Abrasive



Resurfacing Wheel Segments

Segments are available in a variety of compositions.

Match the abrasive to the material for best results and longest life. Order segments in 8, 10 or 12 piece sets.

Width	Thickness	Length	Application	Abrasive	Color	Jobber 1+	Jobber 8+	Order No.
2.56"/65mm	0.98"/25mm	3.94"/100mm	Cast Iron & Aluminum	Silicon-Carbide	Black	\$26.99	\$24.29	GS-PBS
			Steel & Hardened Metals	Aluminum Oxide	White	26.99	24.29	GS-PBS-1
			Aluminum, Cast Iron,	Aluminum Oxide	Speckled	26.99	24.29	GS-PBS-2
			Hardened Iron & Steel	Aluminum Oxide and Silicon-Carbide				
			Steel & Hardened Metals	Aluminum Oxide	Ruby	26.99	24.29	GS-PBS-3
For Peterson/Peterson Berco 1055 AWL, RSC950 (std.), SYP320, -360, -1000, -1300, RSC1200, -1550, RPYS1500 models. For Winona Van Norman SM-2000, SM-4000/5000, MG-4000, SM-6000C/6000A and MG-3000/3850 models. For Storm Vulcan RT7Y Late (Serial No. 103152 and up) and RT 17Y Late (Serial No. 128697 and up) models.								
3.13"/79mm	0.81"/21mm	3.13"/79mm	Cast Iron & Aluminum	Silicon-Carbide	Black	\$26.99	\$24.29	GS-SVS
			Aluminum, Cast Iron, Hardened Iron & Steel	Aluminum-Oxide and Silicon-Carbide	Speckled	26.99	24.29	GS-SVS-2
For Peterson/Peterson Berco RG-32, RTY, RG-35, RG-300/900 models. For Storm Vulcan RT 7Y Early (Serial no. up to 103151) and RT 17Y Early (Serial no. up to 128696)								
1.97"/50mm	0.67"/17mm	3.62"/92mm	Cast Iron & Aluminum	Silicon-Carbide	Black	\$26.99	\$24.29	GS-RGS
For Peterson/Peterson Berco RG-32, RG-300/900 models.								
2.56"/65mm	0.79"/20mm	3.94"/100mm	Steel & Hardened Metals	Silicon-Carbide	Black	\$26.99	\$24.29	GS-KWS
			Aluminum, Cast Iron, Hardened Iron & Steel	Aluminum-Oxide and Silicon-Carbide	Speckled	26.99	24.29	GS-KWS-2
For Kwik-Way 858 and 862 models								

tech tips

from the techxperts™

To maintain proper cutting action Goodson strongly recommends that you replace your cylinder head resurfacing segments in full sets. See your user's manual for wheel diameter and number of segments required. Due to manufacturing process colors may vary.

Need help choosing the abrasive? Call the Goodson Techxperts™

Resurfacing Segments are guaranteed for 1 year from original purchase date

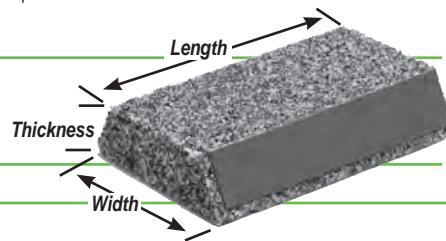

Import / Metric Cylinder Head Stud Stretchers

- Save time, don't remove the studs from a head for resurfacing
- Put stud stretchers on two studs and leave the rest
- Sold in pairs

Length	Thread	Jobber	Order No.
3"	8mm x 1.25	\$58.99	SS-20
3 3/4"	8mm x 1.25	58.99	SS-30
3 3/4"	10mm x 1.25	58.99	SS-40

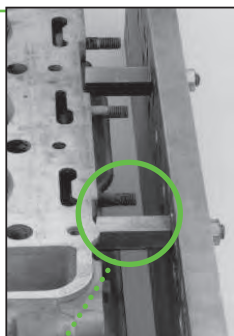

Surface Grinding Coolant for Segments and Single-Piece Wheels

- Synthetic
- Water soluble
- Non-foaming • Dilute 20:1

Size	Jobber	Order No.
1 Gallon / 3.78 L	\$ 32.99	SGC-10
5 Gallons / 18.93 L	149.99	SGC-50

Cylinder Head Resurfacing

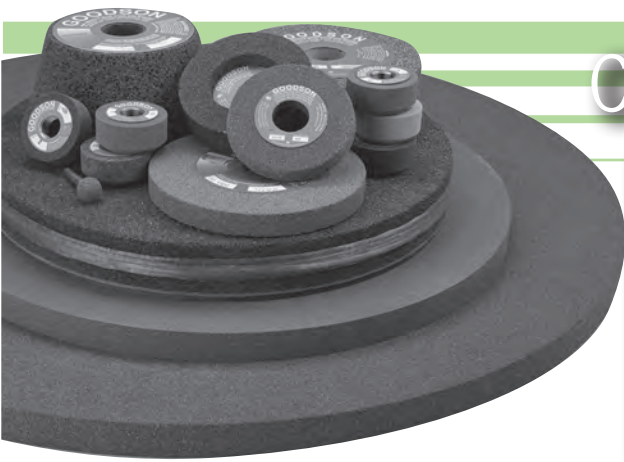

24 Grit Blanchard Grinder Wheels

- Includes gasket pad for mounting onto a Blanchard Grinder
- Also ideal for resurfacing clutch plates
- Wheel measures 11" x 5" x 9"
- Tape wound for added safety
- Excellent grade for most grinding conditions and metals
- Order No. **U69755** Jobber \$199.99



Radiae
Abrasives
A TYROLIT Company

The most complete abrasives program in the industry ...

1. Consistent high quality abrasives

Each Goodson resurfer wheel is made to the highest standards of roundness, balance and strength. Extensive quality control, start-to-finish, lets us back our abrasives with our Iron-Clad Guarantee of total satisfaction.

2. Full inventory

Since we specialize in the distribution of abrasives to machine shops world wide we always carry an extensive inventory. Call Goodson, we have what you need on our shelves.

3. Same day shipping

We usually ship your order the same day that we receive it. Along with our huge inventory, our shipping speed ensures consistently faster delivery when you order from Goodson.

Single-piece Resurfer Wheels

- Meet or exceed OE standards established for general purpose grinding applications
- Silicon-Carbide abrasive • Banding will wear off to expose more abrasive



U342040



GS-48

Peterson

Machine Model(s)	Size: dia. x height x face width	Grit	Jobber	Order No.
All 14" Dry Grinders	14" x 1½" x 4" Plate	24	\$344.99	U342040 Radiae
All 14" Dry Grinders	14" x 1½" x 4" Plate	36	509.99	GS-48

Grinding Wheels are guaranteed for 1 year from original purchase date



GS-545B



GS-545BL

Kwik-Way

Machine Model(s)	Size: dia. x height x face width	Grit	Jobber	Order No.
545B,856,855-5,860	14" x 3" x 1½" (Serrated) Plate	24	\$629.99	GS-545B
545BL,860A, L & T	16" x 3" x 1½" (Serrated) Plate	24	754.99	GS-545BL

Grinding Wheels are guaranteed for 1 year from original purchase date



FG-1165-G



FG-1070A-G

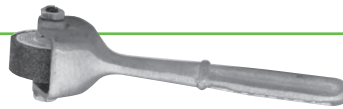

FG-1045-G



GS-17



GS-00



GS-0

Grinding Wheel Dressers & Replacement Cutters

Diamond Dresser Tools are available on pages 116-117

Applications	Cutter Assemblies				Replacement Cutters						
	OD	W	Jobber	Order No.	Pieces	Washers	OD	ID	Thick	Jobber	Order No.
Peterson (12mm shaft)					8 stars	3	2.375"	1.50"	.093"	\$29.99	GS-17
						1 w/locking tangs	1.75"	1.50"	.060"		
WVN SM2000, 4000, 5000, 6000C, 6000A, MG3000, 3850	1.250"	.978"	\$32.99	FG-1165-G	7 stars	none	1.25"	0.313"	.095"	8.99	FG-1161-G
Peterson & DCM	2.375"	2.262"	84.99	FG-1070A-G	5 stars		2.375"	1.132"	.1375"	18.99	FG-1070-G
Hand held			56.99	FG-1045-G	1 stone	none	1.50"	0.313"	.6250"	14.99	FG-1044-G
Desmond-Style Dresser for wheels to 10"			24.99	GS-0	4 blades, 2 spacers		0.250"			8.99	GS-10
					4 blades, 2 spacers		0.500"			9.99	GS-11

CYLINDER HEAD REBUILDING
CLEANING, ASSEMBLY & SAFETY
SHORT BLOCK REBUILDING
FLYWHEEL GRINDING
CRANKSHAFT/
MISCELLANEOUS TOOLS & SUPPLIES
BRAKE SERVICE TOOLING
MEASURING TOOLS
V-TWIN & METRIC HARD PARTS

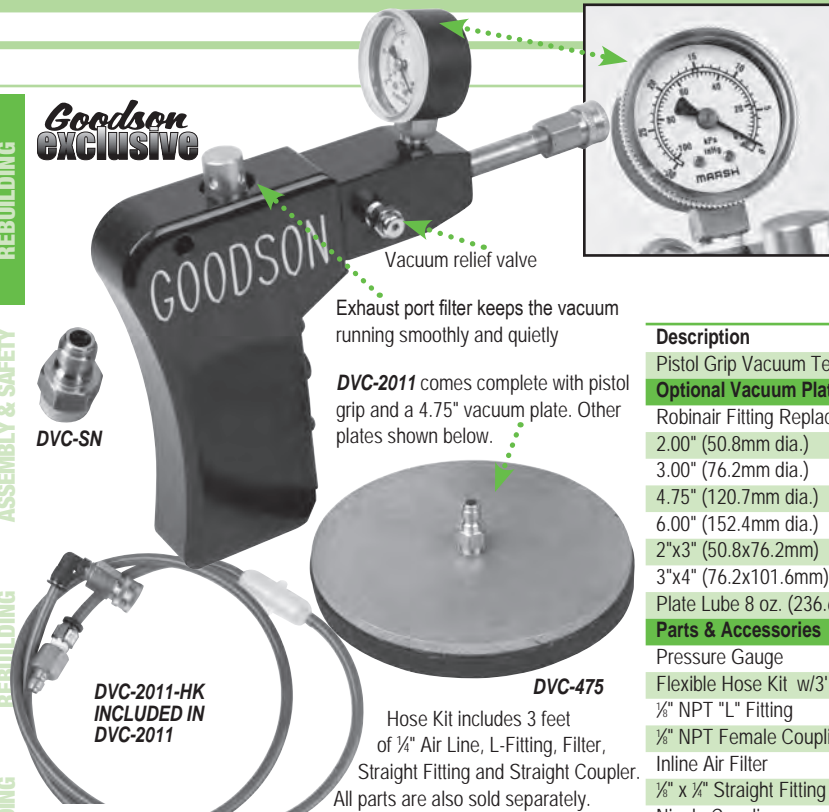
Goodson
exclusive

DVC-SN

DVC-2011-HK
INCLUDED IN
DVC-2011

DVC-475

Exhaust port filter keeps the vacuum
running smoothly and quietlyDVC-2011 comes complete with pistol
grip and a 4.75" vacuum plate. Other
plates shown below.Hose Kit includes 3 feet
of 1/4" Air Line, L-Fitting, Filter,
Straight Fitting and Straight Coupler.
All parts are also sold separately.Scan the code at left
with your smart phone
or other device to view
the product video.**Pistol Grip Vacuum Tester**

- Lightweight - only 1.9 lbs. without the plate
- Pulls and holds up to 24" vacuum on as little as 90 PSI • Quick coupling Robinair fittings
- Easy to reach controls for single-handed operation • Hard-anodized billet aluminum
- Tester includes one 4.75" vacuum plate and hose kit with filter

Description	Jobber	Order No.	Incl. ▼
Pistol Grip Vacuum Tester Kit	\$799.99	DVC-2011	Incl. ▼
Optional Vacuum Plates			
Robinair Fitting Replacement Plate Set	\$174.99	DVC-7KIT	▼
2.00" (50.8mm dia.)	26.99	DVC-2	x
3.00" (76.2mm dia.)	29.99	DVC-3	x
4.75" (120.7mm dia.)	29.99	DVC-475	x x
6.00" (152.4mm dia.)	32.99	DVC-6	x
2"x3" (50.8x76.2mm)	24.99	DVC-23	x
3"x4" (76.2x101.6mm)	31.99	DVC-34	x
Plate Lube 8 oz. (236.6 mL)	6.49	DVC-PL	x
Parts & Accessories			
Pressure Gauge	\$43.99	DVC-GAUGE	
Flexible Hose Kit w/3' Air Line (optional)	43.99	DVC-2011-HK	▼
1/2" NPT "L" Fitting	5.49	CF-2003-L	x x
1/2" NPT Female Coupling	15.99	LDP-AR-6	x x
Inline Air Filter	12.99	DVC-FILTER	x x
1/2" x 1/2" Straight Fitting	7.49	DVC-SF	x x
Nipple Coupling	8.99	DVC-1N	x x
Air Line	lineal foot price 2.99	CF-2001-AL	x x
Robinair Fitting	7.49	DVC-SN	
1/2" NPT Male Coupling	21.99	DVC-1M	
6 Pc. Replacement Foam Set (1 of each size)	37.99	FOAM-KIT	
Replacement Foam Mat - 11" x 31" x 3/8"	41.99	DVC-1131	

**Trego Electric Vacuum Tester**

- Check valve to seat seal right on the bench or in the engine compartment — no special set up is required
- This unit is equipped with a vacuum piston pump and generates up to 850 Mbar of vacuum • Reads in PSI
- A built-in pressure control knob allows you to control vacuum settings accurately • 115V, 60Hz, 67W motor
- Dimensions: 9⁷/₈"L x 6³/₄"W x 4¹/₂"H

Description	Jobber	Order No.	Incl.
Electric Vacuum Tester	\$1599.99	VT-KIT	▼
2.00" (50.8mm dia.)	26.99	DVC-2	x
3.00" (76.2mm dia.)	29.99	DVC-3	x
4.75" (120.7mm dia.)	29.99	DVC-475	x
6.00" (152.4mm dia.)	32.99	DVC-6	x
2"x3" (50.8x76.2mm)	24.99	DVC-23	x
3"x4" (76.2x101.6mm)	31.99	DVC-34	x
Plate Lube 8 oz. (236.6 mL)	6.49	DVC-PL	x
1/4" Air Line (6')	lineal foot price 2.99	CF-2001-AL	x
Inline Air Filter	12.99	DVC-FILTER	x
1/2" NPT Female Coupling	15.99	LDP-AR-6	x

Heavy Duty Manual Vacuum Tester

- A steady reading of 25" (63.5cm) indicates proper valve seating
- All metal construction
- 4³/₄" plate, fittings and plate lube included
- DVC Plates (above) will fit this tester



Description	Jobber	Order No.
Manual Vacuum Tester	\$179.99	DVC-101-HD
Replacement 4.75" Plate	29.99	DVC-475
Plate Lube - 8 oz. (236.6 mL)	6.49	DVC-PL

Sioux-Style Replacement Vacuum Tester Parts

- For Sioux™ 1630K Tester no longer made
- Closed cell foam for an exceptional seal



Sioux-Style Replacement Plates for the 1630K Tester			
Size	OE No.	Jobber	Order No.
2" / 50.8mm dia.	1630-2	\$34.99	SVT-2
3" / 76.2mm dia.	1630-3	37.99	SVT-3
4.75" / 120.7mm dia.	1630-4	37.99	SVT-475
6" / 152.4mm dia.	1630-6	43.99	SVT-6
2"x3" / 50.8 x 76.2mm		34.99	SVT-23
3x4" / 76.2 x 101.6mm		37.99	SVT-34
Replacement Parts for the 1630K Tester			
Replacement Fitting		\$14.99	DVC-SX
Replacement Gauge		49.99	1630-GAUGE

Dye Penetrant Crack Detection



Scan the code below with your smart phone or other smart device to view our **Chemical Crack Detection** Video on the Goodson website.



Alumni-Chek

- Find surface cracks on aluminum & cast iron without electricity or special lights
- Ideal for aluminum, but also works on brass, cast-iron, steel, carbide, and Stellite • Even the tiniest cracks show as bright red • Complete kit includes Cleaner, Penetrant, Developer and Shop Towels (also available separately)

Description	Jobber 1+	Jobber 12+	Order No.	Incl.
Complete Kit	\$44.99		AC-KIT*	▼
Cleaner Aerosol*	20.99	\$18.89	AC-1*	x
Penetrant Aerosol*	20.99	18.89	AC-2*	x
Developer Aerosol*	20.99	18.89	AC-3*	x
5 Towels	3.99		WST-5	x

Mix or match Cleaner, Penetrant & Developer to make a case of 12 and SAVE 10% OFF Jobber!

*Hazardous Goods Fees Apply When Shipped By Air



Oil Dye for Gasoline Engines

- Put into a running engine to find hidden leaks
- Check engine oil **IN** the vehicle
- Use before disassembly to plan repairs
- Use after rebuilding to ensure satisfaction, or to find and fix warranty complaints
- Add dye to oil
- No pre-cleaning required
- Run vehicle briefly to distribute the dye
- Inspect with UV light (**DFL-364** see below)
- Finds even the tiniest of leaks
- Order No. **GLO-GED** Jobber \$12.99



Maxxeon® WorkStar® 364 USB Rechargeable UV Leak Detection Pen/Inspection Light

- 3.7V 570mAh, 2.1 Wh Lithium battery with USB charger
- Run time: 35 min. continuous, 2 hr. intermittent operation
- Use with Goodson Glow for crack detection
- Easily adjustable beam to suit application
- Drop tested to 6 feet
- Order No. **DFL-364** Jobber \$44.99

tech tips

from the techxperts™

- Step 1:** Spray cleaner evenly on the surface and allow it to dry completely.
- Step 2:** Spray on Penetrant. Allow to saturate for 5 minutes. Wipe off excess to avoid false readings.
- Step 3:** Spray on thin layers of developer to build up a uniform powdery film.
- Step 4:** Flaws and cracks will glow brightly when viewed under the black light (Applies only to Goodson Glow).



GOODSON Glow Crack Detection Sprays

- Easily detect surface cracks that could easily be missed with just visual inspection
- Cracks & flaws glow brightly under black light after treatment with Cleaner, Penetrant and Developer

Description	Jobber 1+	Jobber 12+	Order No.
Goodson Glo Cleaner Aerosol*	\$21.99	\$19.79	GLO-1*
Goodson Glo Penetrant Aerosol*	26.99	24.29	GLO-2*
Goodson Glo Developer Aerosol*	32.99	29.69	GLO-3*

Mix or match Cleaner, Penetrant & Developer to make a case of 12 and SAVE 10% OFF Jobber.

*Hazardous Goods Fees Apply When Shipped By Air



Crack Detection Powder & Oil Carrier

- For wet method crack detection
- Mix powder with oil carrier
- Use with Ultra Violet Inspection Light to view results

	Size	Jobber	Order No.
Powder	4 oz. / 113.4g	\$ 53.99	GCR-14A-4
	1 lb. / 453.6g	209.99	GCR-14A
Oil Carrier	5 Gallons / 18.93L	144.99	GCR-50



Magnetic Crack Detection Oil

- Oil impregnated with magnetic powder (**GCR-14A**, **GCR-14A-4**) to glow under black-light
- Low viscosity oil flows into small cracks • Oil clarity makes cracks easier to see • Aerosol Spray is pre-mixed oil and carrier

Description	Jobber	Order No.
16 oz. Aerosol Spray	\$32.99	MFA-16*
5 Gallons	169.99	MFA-50*

*Hazardous Goods Fees Apply When Shipped by Air



CYLINDER HEAD REBUILDING
CLEANING, ASSEMBLY & SAFETY
SHORT BLOCK REBUILDING
FLYWHEEL GRINDING
CRANKSHAFT/ TOOLS & SUPPLIES
MISCELLANEOUS TOOLS & SUPPLIES
BRAKE SERVICE TOOLING
MEASURING TOOLS
V-TWIN & METRIC HARD PARTS



"Be sure to check out the Goodson website (goodson.com) for product specials, tech tips, Safety Data Sheets, product videos and much more."

- Janet, Goodson Marketing Manager, 21 years of service



Scan the code at right with your smart phone or other smart device to watch **Magnetic Particle Inspection** on the Goodson website.



CYLINDER HEAD
REBUILDING

CLEANING,
ASSEMBLY & SAFETY

SHORT BLOCK
REBUILDING

CRANKSHAFT/
FLYWHEEL GRINDING

MISCELLANEOUS
TOOLS & SUPPLIES

BRAKE SERVICE
TOOLING

MEASURING
TOOLS

V-TWIN & METRIC
HARD PARTS

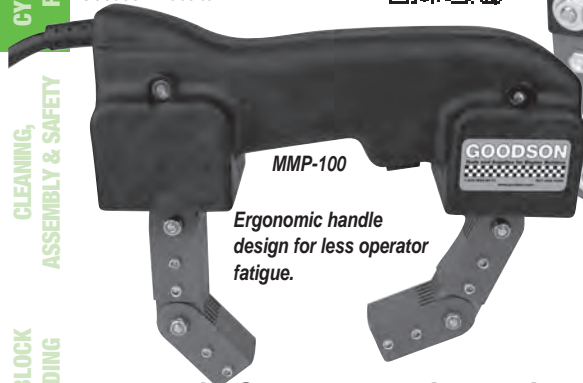

MMP-100
Ergonomic handle
design for less operator
fatigue.

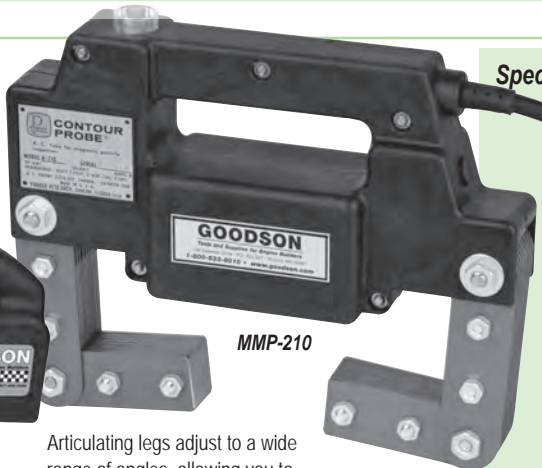

MMP-210

Articulating legs adjust to a wide range of angles, allowing you to test uneven surfaces with ease

Specifications



MMP-100 / MMP-100S
Physical: 7 3/8" x 9 1/4" x 2 1/8"
187 x 235 x 54mm
Max. Span: 12" (304.8mm)
across poles
Voltage: 115V (MMP-100)
230V (MMP-100S)
Line Current: 4 amp (MMP-100)
3 amp (MMP-100S)
Weight: 6.5 lb (2.95 kg)
Cord: 10' L, 3-wire



MMP-210 / MMP-210S
Physical: 10 1/2" x 11" x 2 3/4"
266 x 280 x 70mm
Max. Span: 18" (457mm) across
poles
Voltage: 115V (MMP-210)
230V (MMP-210S)
Line Current: 8 amp (MMP-210)
3 amp (MMP-210S)
Weight: 13 lb (5.9 kg)
Cord: 10' L, 3-wire

Magnetic Crack Detection Units

- Articulating legs conform to virtually any surface configuration
- Designed for one-person operation • Lightweight • No transformer box to drag around • 230V units feature a pigtail on the cord • Easy to access switches • Full 1-Year Manufacturer's Warranty for Repair • 50% duty cycle (example: 2 minutes on, 2 minutes off) • Produce a strong AC magnetic field



Description	Jobber	Order No.
115V Electronic Crack Detector with 10# Pull	\$629.99	MMP-100
115V Heavy Duty Electronic Crack Detector with 22# Pull	749.99	MMP-210
230V Electronic Crack Detector with 10# Pull	579.99	MMP-100S
230V Heavy Duty Electronic Crack Detector with 22# Pull	679.99	MMP-210S

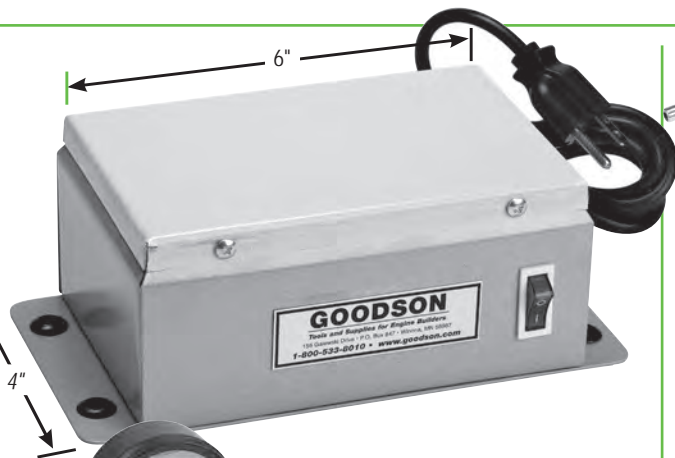

MFI-10010

Small Parts Demagnetizer

Don't jeopardize your engine work! Heat, friction and magnetic particle inspection can cause magnetism to build up in your engine components. If not removed, it will attract ferrous materials in engine lubrication and may cause premature engine failure. This easy to use table demagnetizer is a fast and easy way to ensure that all residual magnetism is eliminated from engine components. Use with the optional Magnetic Field Indicator (**MFI-10010**) to be sure all remaining magnetism has been fully eliminated.

Description	Jobber	Order No.
Small Parts Demagnetizer	\$129.99	SPD-46
Magnetic Field Indicator	97.99	MFI-10010



MM-301

WCD-266-G

MM-301-1

Magnetic Powder Applicators

- A quick & easy method for distributing magnetic powder

Description	Jobber	Order No.
Atomizer Assembly for small areas (1 oz.)	\$27.99	MM-301
Applicator Bulb for large areas	24.99	WCD-266-G
Replacement Bulb for Atomizer Jar	14.99	MM-301-1



Non-Fluorescent Magnetic Powder for Dry Method Particle Inspection

- Works with all dry magnets including Magnaflux® and Parker
- Store in a moisture free environment



Color/Size	1 lb.	5 lb.	25 lb.
White/Gray	WCD-100-G	WCD-500-G	WCD-2500-G
Yellow	WCD-101-G	WCD-501-G	WCD-2501-G
Red	WCD-103-G	WCD-503-G	WCD-2503-G
Jobber ea.	\$10.99	\$49.99	\$249.99



irontite
The Professional's Choice

.235" Crack Repair Kit

- Complete kit includes everything you need to repair cracked cast iron heads using the cold repair process
- Download the Goodson Crack Repair Manual by scanning code at right with the camera on your smart phone or other smart device



Description	Jobber	Order No.	Incl.
Complete Repair Kit:	\$459.99	CRK-150	▼
100 - .235" x 1/16" Threaded Iron Plugs	139.99	CRP-235	1
High Speed Steel Drill	7.99	CRD-235	1
High Speed Steel Tapered Reamer	99.99	CRR-235	1
High Speed Steel Tapered Taps	69.99	CRT-235	2
Cut-Off Saw with Blade	31.99	CR-SAW	1
Replacement Saw Blade	10.99	CR-BLADE	1
Cutting & Tapping Fluid*	13.99	CTF-14	1
All Weather Seal (16 oz.)	23.99	AWS-16	1
Ceramic Motor Seal (16 oz.)	24.99	CRS-16	1

*Hazardous Goods Fees Apply When Shipped By Air

Threaded Crack Repair Plugs

- Iron • Tapered • Threaded plugs
- Cast to rigid specifications

Plug Size	Qty.	Jobber	Order No.
.200" x 1/8"	100	\$137.99	CRP-200
.200" x 1/2"	100	137.99	CRP-201
.235" x 1/8"	100	139.99	CRP-235
.327" x 1/8"	50	119.99	CRP-327



High Speed Steel Drills

- 118° points for fast chip removal

Plug Size	Jobber	Order No.
.200"	\$7.99	CRD-200
.235"	7.99	CRD-235
.327"	8.99	CRD-327



irontite
The Professional's Choice

Tapered Reamers

- High Speed Steel

Plug Size	Jobber	Order No.
.200"		Not Required
.235"	\$ 99.99	CRR-235
.327"	139.99	CRR-327



Tapered Taps

- High strength steel machined to match plug taper & thread

Plug Size	Jobber	Order No.
.200"	\$74.99	CRT-200
.235"	69.99	CRT-235
.327"	86.99	CRT-327



High Performance Crack Inspection Kit

Goodson carries a variety of magnetic crack detection methods including this kit. We include heavy-duty 110V adjustable-leg magnetic yokes made right here in America. The complete kit also includes our oil based magnetic powder spray that glows under UV light and a UV Leak Detection Inspection Light.

Description	Jobber	Order No.	Incl.
High Performance Crack Detection Kit	\$969.99	FCD-HP-KIT*	▼
115V Heavy Duty Electronic Crack Detector	749.99	MMP-210	x
Magnetic Crack Detection Oil Spray*	32.99	MFA-16*	x
Rechargeable Leak Detection Inspection UV Light	43.99	DFL-364	x

*Hazardous Goods Fees Apply When Shipped By Air

Jet Valve Eliminator Kit

- Some Mitsubishi/Chrysler 2.6L heads had jet valves while some didn't
- This kit lets you use a jet valve equipped head in place of one without
- 11mm diameter, 1.0 pitch threaded plugs replace entire valve body assembly
- Easier than welding the holes closed
- Package of 4 converts one 2.6L head
- Order No. **JVE-26** Jobber \$26.99



Head-Bolt Hole Clean-out Taps

- Clean threaded holes to prevent false torque wrench readings
- Lifts rust, dirt, chips and other debris as you remove the tool
- Use with lube and a socket wrench or slow drill
- Repairs minor damage

Size	Pitch	Length	Jobber	Order No.
1/2"	13	3 3/8" OAL	\$ 73.99	BCT-1/2
7/16"	14	3 3/8" OAL	59.99	BCT-7/16
10mm	2.0mm	8" Shank	159.99	BCT-10X2L
11mm	2.0mm	8" Shank	174.99	BCT-11X2L
11mm	1.5mm	8" Shank	134.99	BCT-11L

LS-engines

CYLINDER HEAD
REBUILDING

CLEANING,
ASSEMBLY & SAFETY

SHORT BLOCK
REBUILDING

FLYWHEEL, GRINDING

CRANKSHAFT/
TOOLS & SUPPLIES

MISCELLANEOUS
BRAKE SERVICE
TOOLING

MEASURING
TOOLS

V-TWIN & METRIC
HARD PARTS



"At Goodson, we're always on the lookout for new or improved tools that make engine rebuilding easier. If you have a tool you think we'd be interested in, give us a call."

- Richard, Goodson Product Manager, 23 years of service

CYLINDER HEAD
REBUILDING

CLEANING,
ASSEMBLY & SAFETY

SHORT BLOCK
REBUILDING

CRANKSHAFT/
FLYWHEEL GRINDING

MISCELLANEOUS
TOOLS & SUPPLIES

BRAKE SERVICE
TOOLING

MEASURING
TOOLS

V-TWIN & METRIC
HARD PARTS

shown actual size



melted center
reveals
overheating



Heat Tabs

- Provides visual evidence of engine overheating
- Special heat sensitive metal centers melt and fall out when engine exceeds the melting point of the tab
- 100 Heat Tabs per package
- Attach to heads with Heat Tab Adhesive (below)

Description	Melting Point	Jobber	Order No.
Round Heat Tabs	255-260° F / 124-127° C	\$48.99	RHT-100
Round Ironite Heat Tabs	255-260° F / 124-127° C	88.99	HT-100RD
Round Diesel Heat Tabs	225-235° F / 107-110° C	57.99	DHT-100
Heat Tab Adhesive (3 oz./88.7mL tube)		10.79	HTA-3

Leak Detection Mat

- Commercial-grade Neoprene
- Resists petroleum products, abrasion, swelling, sunlight and aging
- Repair worn mats or make custom leak detection plates
- Measures 3' x 4' x 3/16" thick
- Order No. **LDP-34MAT** Jobber \$95.99



Rust Inhibitor for Pressure Testing

- Clear fluid inhibits rust and does not discolor or cloud the test tank solution
- Lets you see better to pressure test
- Biocide and anti-rust additives extend tank solution life while preventing corrosion
- Synthetic formula
- Mix 20:1 with water
- Yields 20 gallons
- Order No. **PRI-10** Jobber \$32.99



Seal-All™

- Seals pin holes, porosity and small cracks in heads & blocks
- Penetrates and seals
- Out-performs ceramics
- Bonds with existing rust & corrosion to prevent spread
- Heat at 175°-200°F (79.4°-93.3°C) for 4 hours to cure
- Not for use on assembled engines
- 32 oz. (46 mL)
- Order No. **CPS-32** Jobber \$78.99



Fluid Weld®

- For cast iron or aluminum heads and blocks
- Use as a sealant for threaded or press-fit parts like valve guides and seats, threaded crack repair plugs, replacement studs, etc.
- Seals small cracks • Non-toxic
- Non-flammable
- **NOT** for use on assembled engines
- Withstands temperatures to 3000°F



Size	Jobber	Order No.
2 oz. (59 mL)	\$ 49.99	FW-2
8.8 oz. (260 mL)	159.99	FW-88

All Weather Seal

- Seals intakes & head gasket leaks
- Seals cracks in cylinder heads & engine blocks
- Prevents anti-freeze from seeping through gaskets and hoses
- Lubricates water pump seals
- Mixes with all anti-freeze and coolant
- Works in less than 5 minutes
- Fast-acting, non-corrosive, non-clogging
- Can be used with coolant or anti-freeze
- 16 oz./455 mL • Order No. **AWS-16** Jobber \$23.99



Ceramic Motor Seal

- Permanently seals leaking head gaskets, cracked heads and blocks (aluminum or cast iron)
- Coats the engine to inhibit rust formation and salt water corrosion during normal operation
- Seals porous castings in the cooling system
- Stops coolant leaks
- Not compatible with any anti-freeze or coolant, follow instructions on package
- Promotes heat dissipation for added power
- 16 oz./455 mL
- Order No. **CRS-16** Jobber \$24.99



S-373P
Pilot shown installed



Rocker Arm Stud Conversion Kit

- Convert pressed-in rocker arm studs to threaded studs
- Remove stud, face stud boss, then drill and tap the stud hole
- Use with a seat and guide machine

Description	Jobber	Order No.	Incl.
Conversion Kit	\$149.99	S-450-KIT	▼
Stud Boss Facer	139.99	S-450-F	x
3/8" Drill Bit	13.99	S-373D	x
1/8" x 14 Thread Tap	22.99	S-437T	x
3/8" Pilot	51.99	S-373P	
2 Pc. Tap Guide	45.99	S-350G	

made in america

Ultra-Sturdy Cylinder Head Holder

- 360° stand holds head securely in position
- Tie-rod to prevent tipping
- Slip-resistant neoprene covered rails
- Fits domestic, foreign, truck & motorcycle heads
- 3-piece set
- Order No. **HH-450** Jobber \$107.99

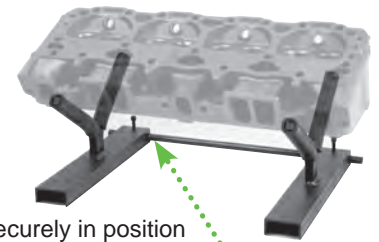

Set screws hold the two pieces firmly in place

Manual Rocker Arm Stud Puller

- Heavy-duty ball bearing action
- Creates less stress and friction
- Fits 5/16" (7.9mm) and 3/8" (9.53mm) threaded studs
- Not recommended for use on thermally cleaned heads

Description	Jobber	Order No.
Complete Stud Puller	\$136.99	SP-600
Drive Nut	27.99	SP-601
Puller Body	57.99	SP-602
5/16" and 3/8" Mandrel	57.99	SP-603
Thrust Bearing	13.99	SP-604

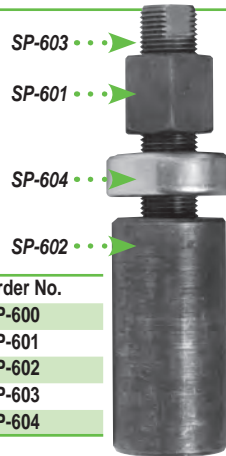

made in america

Universal Cylinder Head Holder

- Accommodates all types of cylinder heads
- Sturdy, durable, lightweight aluminum construction
- Slip-resistant neoprene covered rails
- Place heads quickly into any position and rotate them easily through 360°
- Requires no bolts, clamps or adaptors
- 2 piece set • Order No. **HH-200** Jobber \$159.99

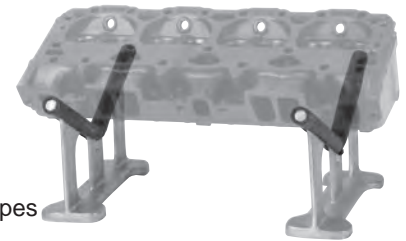

Universal Threaded Stud Extractor

- Use with your pneumatic impact tools & sockets (19/16" socket removes, 17/16" installs)
- Requires only 3/4" clearance to adjacent studs
- For threaded studs only
- Hardened 3-jaw clamping system
- Internal taper support
- Hollow body allows long studs to extend through the tool
- 1 1/2" dia. x 2 7/8" long • 1/4" - 1/2" range

Description	Jobber	Order No.
Universal Stud Extractor	\$167.99	PSR-500
Replacement Parts		
Jaws	127.99	PSR-JAWS
Spring Set	6.99	PSR-3S
Snap Ring	5.99	PSR-SR



made in america

Professional Measuring & Inspection Stand

- Length adjusts up to 23"
- Rotate work to view or measure
- Solid aluminum frame with self lubricating, corrosion and chemical-resistant wear surfaces
- Order No. **PMIS-30** Jobber \$134.99

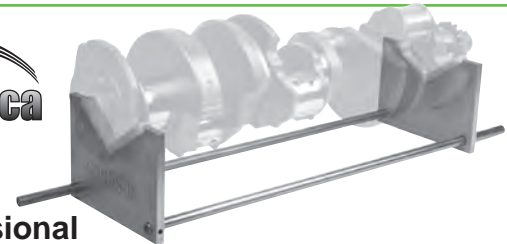

Order 6 or more, Save 10% off jobber 

Torque-Angle Indicator

- When torque is given as degrees of turn past a certain ft./lb., use this gauge to show degrees
- Hold metal base with one hand
- Plastic dial turns as you tighten
- Fits between a socket-driven extension and the socket
- 1/2" square drive
- Order No. **TQR-4554** Jobber \$23.99



Spray Assembly Lube

- Ideal for lubricating parts to ease assembly
- Eliminates critical initial run-in of new and rebuilt high-performance engine components
- Spray on bearings, crankshafts, pistons, rings, etc.
- 11 oz. Aerosol* can • Order No. **SAL-11** Jobber 1+ \$15.99 ea. Jobber 6+ \$14.39 ea.

* Hazardous Goods Fees Apply If Shipped By Air



CYLINDER HEAD REBUILDING
CLEANING, ASSEMBLY & SAFETY
SHORT BLOCK REBUILDING
FLYWHEEL GRINDING
CRANKSHAFT/ TOOLS & SUPPLIES
MISCELLANEOUS
BRAKE SERVICE TOOLING
MEASURING TOOLS
V-TWIN & METRIC HARD PARTS



"We pride ourselves on getting orders to you quickly. We stock a wide variety of products in our warehouse and we use most shipping carriers so you can receive your order in 3 days or less."

- Shawn K. Goodson Shipping, 2 years of service

CYLINDER HEAD
REBUILDING

CLEANING,
ASSEMBLY & SAFETY

SHORT BLOCK
REBUILDING

CRANKSHAFT/
FLYWHEEL GRINDING

MISCELLANEOUS
TOOLS & SUPPLIES

BRAKE SERVICE
TOOLING

MEASURING
TOOLS

V-TWIN & METRIC
HARD PARTS

48 Piece Deluxe Porting Kit

- Professional grade porting supplies
- Packed in a clear plastic storage case

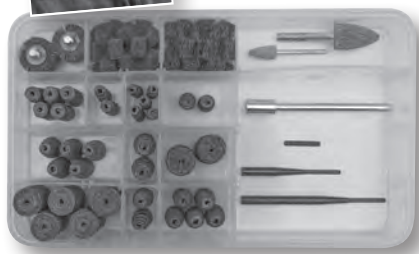

Description	Jobber	Order No.	Incl.
48 Pc. Kit	\$104.99	DPK-100	▼
Replacement Abrasives	Grit	Kit Qty.	
Flap Wheels - 1"x1"x1/4"	120	2	\$ 8.99 AFW-1-120 x
Cross Buffs 3 Ply, 1 1/2"	Med.	2	34.99 CB-15M-HD x
	Very Fine	2	34.99 CB-15VF-HD x
Cross Buff/Flapwheel Mandrel		1	13.99 CB-MANDREL x
1/4" Dia. Straight	40	2	26.29 SCR-250-40 x
Cartridge Rolls	80	5	26.29 SCR-250-80 x
3/8" Dia. Straight	40	2	26.29 SCR-375-40 x
Cartridge Rolls	80	5	26.29 SCR-375-80 x
3/4" Dia. Straight	40	2	62.99 SCR-750-40 x
Cartridge Rolls	80	2	62.99 SCR-750-80 x
1/2" Dia. Half Tapered	40	2	43.99 HTR-500-40 x
Cartridge Rolls	80	5	43.99 HTR-500-80 x
5/8" Dia. Full Tapered	40	2	51.99 FTR-625-40 x
Cartridge Rolls	80	5	48.99 FTR-625-80 x
Cartridge Roll Mandrel	2 3/4" Long	1	10.99 CR-275 x
	4" Long	1	11.99 CR-40 x
Mounted Points - 3/8" x 3/4"	60	1	9.49 GM-B52 x
	1 1/16" x 1 1/4"	60	1 9.49 GM-12 x

See next page for replacement abrasives

small engine powersports

40 Piece Small Engine Porting Kit

- Professional grade porting supplies
- Packed in a clear plastic storage case



Description	Jobber	Order No.	Incl.
40 Pc. Kit	\$73.99	SEPK-5	▼
Replacement Abrasives	Grit	Kit Qty.	
Flap Wheels - 1"x1"x1/4"	120	2	\$ 8.99 AFW-1-120 x
Cross Buffs 2 Ply 3/4"	Very Fine	2	21.99 CB-75VF x
	1"	Medium	21.99 CB-1M x
	Very Fine	2	21.99 CB-1VF x
	1 1/2"	Very Fine	2 25.99 CB-15VF x
Cross Buff/Flapwheel Mandrel		1	13.99 CB-MANDREL x
3/8" Dia. Straight	80	4	26.29 SCR-375-80 x
Cartridge Rolls	120	4	26.29 SCR-375-120 x
	320	4	31.49 SCR-375-320 x
3/8" Half Tapered Cartridge Rolls	80	4	41.99 HTR-375-80 x
3/8" Full Tapered	80	4	32.99 FTR-375-80 x
Cartridge Rolls	120	4	32.99 FTR-375-120 x
1" x 2 Yds. Abrasive Roll	120	1	22.99 UR-1-120 x
	320	1	32.99 UR-1-320 x
Cartridge Roll Mandrel	2 3/4" Long	1	10.99 CR-275 x
	4" Long	1	11.99 CR-40 x

See next page for replacement abrasives

Intake Port Reshaping Kit

- Superior formula uses 2-part epoxy
- Won't shrink when dry
- Mix ratio is 1:1 by weight
- Mix and knead the parts together by hand until the yellow and black colors have combined to make a uniform olive green color
- Working time at 70°F: Golfball size mix: 40 minutes max.; Baseball size mix: 30 minutes max.
- Cure time at 70°F: full hardness in 6 to 8 hours
- Once cured, forms a hard coating resistant to abrasion, impact, water, chemicals and solvents
- **NOT** for use in contact with potable water or exhaust ports
- Can be milled or machined
- Withstands temperatures up to 500°F/ 260°C
- Kit includes epoxy, gloves and mixing sticks
- Yields 16 oz./453.6g of material
- 24 month shelf-life
- Order No. **PRK-99** Jobber \$39.99



tech tips

Adhesion of PRK-99 will be only as good as the cleanliness and soundness of the substrate. Remove all dirt, oil and grease. Soda blasting is acceptable. Scraping, wire brushing and other manual cleaning methods may also work. Do NOT use a petroleum-based cleaner before using PRK-99, it will prohibit adhesion.

Quick Change Mandrels & Abrasive Sleeves

- 5 sleeves per pack • 1" x 1"
- Mandrel has 1/4" shaft

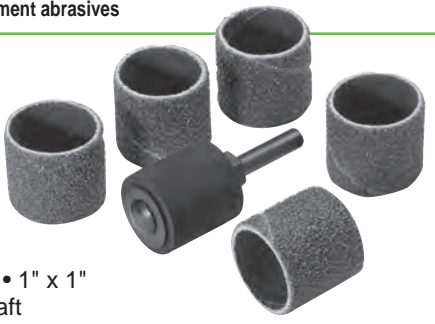

Description	Grit	Jobber	Order No.
Mandrel		\$9.49	GMS-101
Sleeves	40	9.99	GMS-140
5 Pack	60	9.99	GMS-160



Variable Speed Control

- Vary tool speed from 200 to 25,000 RPM • Control switch with 3 settings – Variable Speed, OFF and Full Speed • Speed control dial
- Built in grounded control outlet • Not compatible with brushless motors
- Order No. **GEO-SC** Jobber \$49.99

NOTE: Extreme caution must be used when porting & polishing. Be sure to wear safety glasses.

Professional Porting & Polishing Tools

Aluminum Oxide Cloth Utility Shop Rolls

- 1" x 50 yards
- Easy to use ... just unroll and tear to length
- Use with butterfly mandrels at right



Grit	Jobber	Order No.
60	\$21.99	UR-1-60
80	23.99	UR-1-80
100	21.99	UR-1-100
120	22.99	UR-1-120
180	21.99	UR-1-180
320	32.99	UR-1-320

Crocus Cloth

- Must be used with Lapping Oil
- Great for final touch-ups on cranks, rod pins, valve stems, cams, etc.
- Use with slotted mandrels at right



Description	Jobber	Order No.
1" x 50 yd. Roll	\$43.99	UR-1-CROCUS
4 oz. Lapping Oil	11.49	LP-LO-4
8 oz. Lapping Oil	19.99	LP-LO-8



Slotted Butterfly Mandrels

- Use with roll abrasives such as those at left
- Several lengths available

Length	Jobber	Order No.
3"	\$ 6.99	BM-3
6"	11.99	BM-6
8"	13.99	BM-8

Want a different abrasive? We can make it in-house. Contact us for more information!

Replacement Abrasive Packs and Mandrels

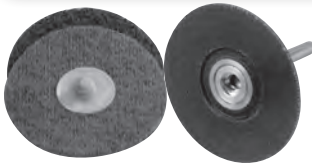

Replaceable Roll Lock Discs

10 per pack.

Dia.	Jobber	Order No.
2"	Medium \$11.49	RSCD-2M
	Coarse 13.99	RSCD-2C
3"	Medium 18.79	RSCD-3M
	Coarse 22.99	RSCD-3C
Disc Holder	Jobber	Order No.
2" Dia.	\$16.99	RLH-2
3" Dia.	18.99	RLH-3



Aluminum Machining Aid

- Designed for aluminum
 - For porting & polishing with cartridge rolls, rotary files, emery cloth or Cross Buffs®
 - Safe for cast iron
 - 32 oz./946.4mL
 - Order No. **PF-32** Jobber \$51.99
- HazMat shipping charges apply when shipped by air

Straight Cartridge Rolls

- 1½" long, ¼" hole
- Fully glued • Box of 50

Dia.	Grit	Jobber	Order No.
¼"	40	\$26.29	SCR-250-40
	80	26.29	SCR-250-80
	120	26.29	SCR-250-120
¾"	40	26.29	SCR-375-40
	80	26.29	SCR-375-80
	120	26.29	SCR-375-120
1½"	40	31.99	SCR-500-40
	60	31.99	SCR-500-60
	80	31.99	SCR-500-80
2"	100	31.99	SCR-500-100
	120	31.99	SCR-500-120
	¾"	40	62.99
	80	62.99	SCR-750-80
	120	62.99	SCR-750-120

Roll Mandrels

Use with straight and tapered cartridge rolls • ½" pilot x ¼" dia.

OAL	Jobber	Order No.
2¼"	\$10.99	CR-275
4"	11.99	CR-40
6"	12.99	CR-60
8"	14.99	CRM-8H
10"	14.99	CRM-10H
12"	14.99	CRM-12H

Mirrored Safety Glasses

- Wrap-around design
- Tinted lenses provide sun glare protection
- Universal bridge
- Polycarbonate lenses
- **Do not** use as welders helpers
- Order No. **PGL-21** Jobber \$6.49



Half-Tapered Cartridge Rolls

- 1½" long, ¼" hole
- Fully glued • Box of 50

Dia.	Grit	Jobber	Order No.
¾"	40	\$39.99	HTR-375-40
	80	41.99	HTR-375-80
1½"	40	43.99	HTR-500-40
	80	43.99	HTR-500-80

Full-Tapered Cartridge Rolls

- 1½" long, ¼" hole
- Fully glued • Box of 50

Dia.	Grit	Jobber	Order No.	
¾"	40	\$34.99	FTR-375-40	
	80	32.99	FTR-375-80	
	120	32.99	FTR-375-120	
1½"	40	32.99	FTR-375-320	
	60	34.99	FTR-500-40	
	80	34.99	FTR-500-60	
2"	120	48.99	FTR-500-120	
	¼"	40	51.99	FTR-625-40
	80	48.99	FTR-625-80	



Premium Quality

- Aluminum-Oxide
- Box of 10

Dia.	Grit	Jobber	Order No.
2-Ply			
¾"	V. Fine	\$21.99	CB-75VF
	Med.	21.99	CB-75M
1"	V. Fine	21.99	CB-1VF
	Med.	21.99	CB-1M
1½"	V. Fine	25.99	CB-15VF
	Med.	25.99	CB-15M
3-Ply			
1¼"	Med.	34.99	CB-125M-HD
1½"	V. Fine	34.99	CB-15VF-HD
	Med.	34.99	CB-15M-HD

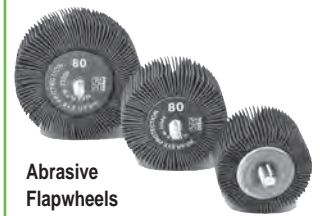

Abrasive Flapwheels

- 1" wide, ¼" x 20 threaded
- Aluminum-Oxide • 1 each

Dia.	Grit	Jobber	Order No.
1½"	80	\$12.99	APK-7
1"	120	8.99	AFW-1-120
2"	120	9.99	AFW-2-120
3"	120	11.99	AFW-3-120



- Use with Cross Buffs & Flap Wheels above

Description	Jobber	Order No.
4" Mandrel	\$13.99	CB-MANDREL
Set Screw (3)	6.49	CB-SCREW

NOTE: Extreme caution must be used when porting & polishing. Be sure to wear safety glasses.



"We do our best to get our inventory on the shelves; professionally and correctly packaged and ready for when you need it."

— Shane, Goodson Receiving Supervisor, 5 years of service

CYLINDER HEAD
REBUILDING

FR-34-C



1/4" Shank Carbide Rotary Double Cut Files

FR-45-C

Dia.	Length	Shank	Jobber	Order No.
1/2"	1 1/8"	1.1"	\$45.99	FR-34-C
1/4"	1"	1.0"	37.99	FR-45-C

CLEANING,
ASSEMBLY & SAFETY

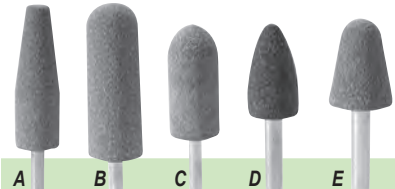

SHORT BLOCK
REBUILDING

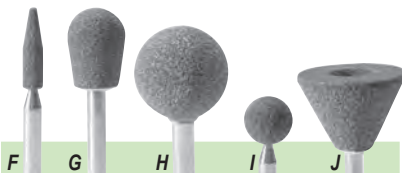

CRANKSHAFT/
FLYWHEEL GRINDING



MISCELLANEOUS
TOOLS & SUPPLIES

1/4" Shank Mounted Points

• Aluminum-Oxide abrasive is ideal for roughing cast iron • 1 1/2" shank length

Dia.	Length	Grit	Jobber	Order No.
A 3/4"	2 1/2"	60	\$9.49	GM-1
B 7/8"	2 3/4"	60	9.49	GM-3
C 7/8"	1"	60	9.49	GM-11
D 1 1/16"	1 1/4"	60	9.49	GM-12
E 3/4"	1 1/8"	60	9.49	GM-5
F 1/4"	1 1/16"	60	9.49	GM-15
G 3/4"	1"	60	9.49	GM-23
H 1"	1"	60	9.49	GM-25
I 5/8"	5/8"	60	9.49	GM-26
J 1 3/8"	1"	60	9.49	GM-31
K 1"	1"	60	9.49	GM-38
L 3/4"	3/4"	40	9.49	GM-40
M 3/8"	3/4"	60	9.49	GM-B52
N 1 1/2"	1 1/16"	60	9.49	GM-236

BRAKE SERVICE
TOOLING

MEASURING
TOOLS

tech tips
from the techxperts™

Stay Safe:

Always ensure your burr shank is well inserted into your collet and clamped down tightly.

Keep pressure light and keep the burr moving focusing on the highest material first.

Ensure your work is secured tightly to your work bench.

Don't snag or jam your burr into your work.

Wear eye protection as a minimum, but better still, use a full shield for your face.

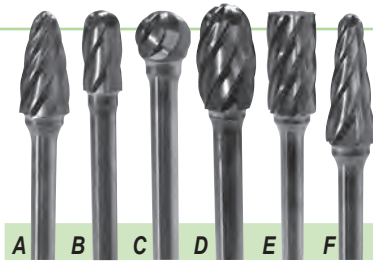

6" Long 1/4" Dia. Shank Open Fluted Rotary Files for Aluminum

- Carbide burrs
- Open flute design gives better chip discharge

Dia.	Length	Jobber	Order No.
A 1/2"	1"	\$87.99	LAFR-34
B 3/8"	3/4"	49.99	LAFR-45
C 1/2"	7/16"	66.99	LAFR-55
D 1/2"	7/8"	84.99	LAFR-70
E 1/2"	1"	64.99	LAFR-93
F 3/8"	1 1/16"	97.99	LAFR-121

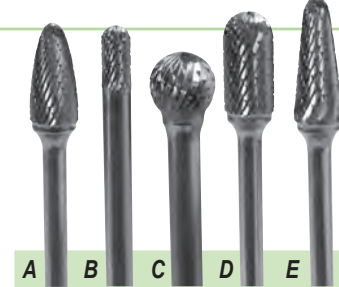

6" Long Shank Double Cut Carbide Rotary Files

- 1/4" diameter shank

Save when you buy the kit!

Dia.	Length	Jobber	Order No.	Incl.
Complete 5 Pc. Kit		\$269.99	LFR-KIT	▼
A 1/2"	1 1/8"	64.99	LFR-34C	x
B 1/4"	1/2"	59.99	LFR-45C	x
C 1/2"	1/2"	59.99	LFR-55C	x
D 1/2"	1 1/16"	79.99	LFR-46C	x
E 1/2"	1 1/8"	66.99	LFR-141C	x



Order 5 or more Rotary Files, Burrs or Mounted Points (mix & match) and save 10% off jobber



1/4" Carbide Rotary Files

- Nose design reduces back-gouging
- 1/4" shank • Shanks 4" long except MRT-56C at 6" long

Dia.	Lgth.	Jobber	Order No.
A .375"	1.000"	\$49.99	MSH-34C
B .437"	.875"	53.99	MSE-44C
C .500"	.975"	64.99	MRT-54C
D .500"	1.000"	64.99	MRT-56C

Dia.	Lgth.	Jobber	Order No.
E .500"	.880"	\$53.99	MSE-54C
F .500"	1.000"	49.99	MSF-54C
G .500"	1.245"	53.99	MSH-54C



V-TWIN & METRIC
HARD PARTS



Bifocal Magnifying Safety Glasses

- Safety glasses and cheaters all in one • Anti-fog lenses
- Do not use as welders helpers

Diopter	Jobber	Order No.
1.00	\$12.99	BSG-100
1.25	12.99	BSG-125
1.50	12.99	BSG-150



Mirrored Safety Glasses

- Wrap-around design
- Tinted lenses provide sun glare protection
- Universal bridge
- Polycarbonate lenses
- Do not use as welders helpers
- Order No. PGL-21 Jobber \$6.49

Dual Overhead Cam Cylinder Head Organizer Tray

- Store valves, springs, retainers, keepers, valve lash adjusters & camshafts • Keep valve lash adjusters from getting mixed up and changing valve adjustment
- Heavy duty construction
- Oil and solvent resistant
- Measures: 23 1/4" x 26 1/2" x 2"H
- Order No. **DOHC-1**
Jobber 1+ \$52.99 each,
Jobber 6+ \$47.69 each

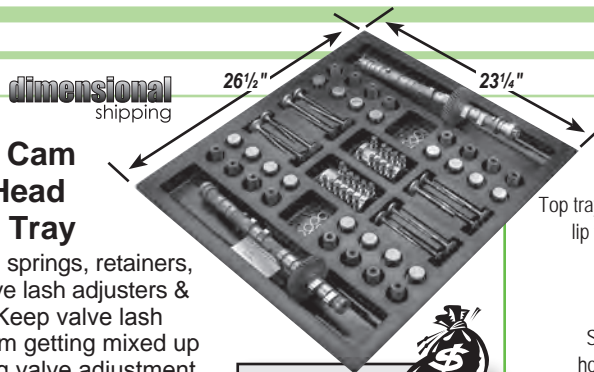

dimensional shipping

Parts Trays

Order 6 or more and SAVE 10% off jobber, Mix or match trays to make quantities

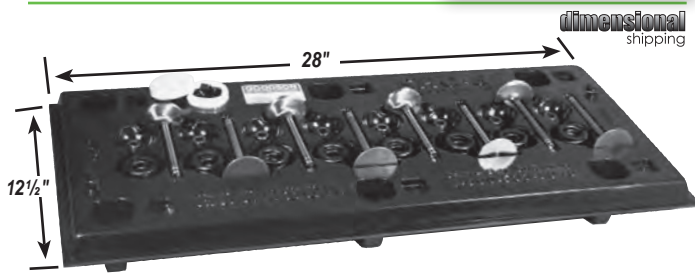

dimensional shipping

Stackable Cylinder Head Organizer Trays

- Store valves, springs, retainers and keepers in order of assembly • Impervious to oil and most solvents
- Measures 28" x 12 1/2" x 3"H
- Order No. **SHO-8**
Jobber 1+ \$61.99 each, Jobber 6+ \$55.79 each



Valve Train Tray For 4, 6 or 8-Cylinder OHV Engines

- Heavy duty construction
- Keeps push rods, rockers, lifters, etc. in order
- 64 compartments
- Measures: 11 7/8"W x 23 1/4"L x 1 3/4" H
- Order No. **VTO-80**
Jobber 1+ \$52.99 each,
Jobber 6+ \$47.69 each

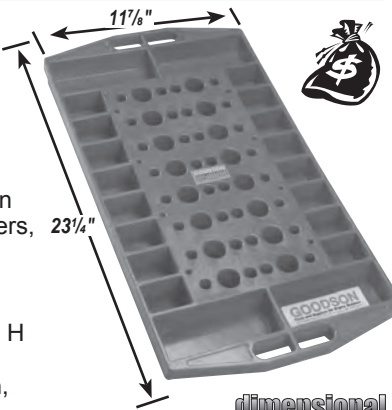

dimensional shipping

Ford/Chevy Small Block Organizer Tray

- Store pistons, rods, lifters, push rods & camshafts
- Formed compartments keep engine components securely in place
- Measures: 24 1/4" x 25 1/2" x 1 1/2"D
- Order No. **iEO-80**
Jobber 1+ \$47.99 each,
Jobber 6+ \$43.19 each

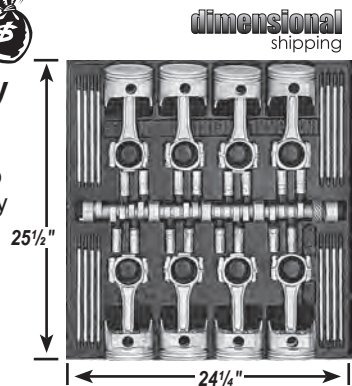

dimensional shipping

Top tray features 1" deep lip to keep parts from rolling off

Solid steel hangers hold piston rods and crankshafts
Heavy duty casters make moving the engine and cart easy

Engine Storage Cart

- An efficient space-saver
- Heavy-duty casters
- Holds all engine parts off the floor from tear-down to reassembly in less than 4 square feet
- Move the whole engine easily
- Some assembly required
- Order No. **EC-200**
Jobber \$459.99

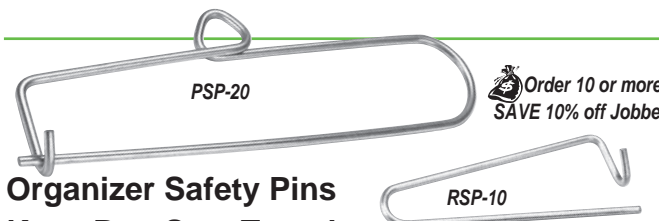
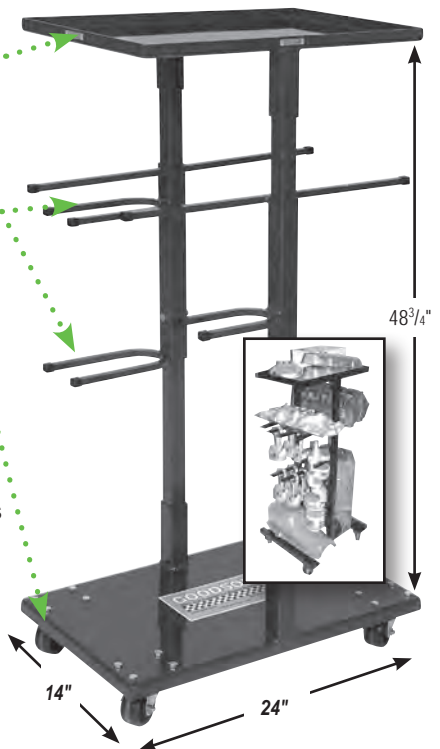

Order 10 or more, SAVE 10% off Jobber

Organizer Safety Pins Keep Part Sets Together

Parts Safety Pin • Organize valve springs, rods, etc., from disassembly to cleaning to reassembly
Rod & Cap Mini Pin • Keep connecting rods & rod caps together to prevent mix-ups

Description	Jobber 1+	Jobber 10+	Order No.
Parts Safety Pin (3/4" x 12")	\$6.99 ea.	\$6.29 ea.	PSP-20
Rod & Cap Mini Pin (3/4" x 4")	3.49 ea.	3.14 ea.	RSP-10

Mix or match to make quantity break

Parts Tags & Marker

- Won't tear or wash off
- Heavy wire ties
- Tough enough to go through a jet wash or hot tank
- Includes 2 Super-Permanent markers with specially formulated ink to withstand most chemicals and extreme heat and steam up to 500°F
- Tag dimensions: 3 1/2"L x 5/8"W with 5/32" hole for wire tie



Description	Jobber	Order No.
1000 Parts tags, with 2 markers	\$80.99	IDT-1000
Super-Permanent Marker only	3.49	IDT-MARKER

CYLINDER HEAD REBUILDING
CLEANING, ASSEMBLY & SAFETY
SHORT BLOCK REBUILDING
CRANKSHAFT/ FLYWHEEL GRINDING
MISCELLANEOUS TOOLS & SUPPLIES
BRAKE SERVICE TOOLING
MEASURING TOOLS
V-TWIN & METRIC HARD PARTS

... another satisfied customer

"outstanding customer service; always. Goodson has gone above and beyond to assure we have the tooling we need."

— Jimmy Stray, Metro Motor Center, Houston, TX, Goodson customer since 1990

CYLINDER HEAD REBUILDING

Brass or Steel Shim Stock Assortment Packs

- A handy assortment • 4" x 6" each (120 sq. in.)
- One each of .001", .002", .003", .005", .010" thick

Description	Jobber	Order No.
Brass	\$13.99	SSB-50
Steel	13.99	SSS-51

CLEANING, ASSEMBLY & SAFETY

SHORT BLOCK REBUILDING

Brass or Steel Shim Stock Rolls

- Roll measures 6" wide x 100" long
- Use only what you need
- Always have shim stock on hand

Thickness	Brass		Steel	
	Jobber	Order No.	Jobber	Order No.
.001"	\$32.99	SSB-01R	\$26.99	SSS-01R
.002"	33.99	SSB-02R	26.99	SSS-02R
.003"	35.99	SSB-03R	26.99	SSS-03R
.005"	39.99	SSB-05R	26.99	SSS-05R
.010"	64.99	SSB-10R	26.99	SSS-10R

CRANKSHAFT/ FLYWHEEL GRINDING

MISCELLANEOUS TOOLS & SUPPLIES

Two Blade Spot Facer

- 1 1/4" OD Spot Facer located on 3/8" stud
- Removes unneeded material for easier removal and installation of screw-in studs
- Replaceable carbide blades

Description	Jobber	Order No.	Incl.
Stud Boss Facer	\$144.99	SBF-5587	▼
Stud Boss Facer Tip (each) for SBF-5587 only	21.99	SBF-5587T	x
Stud Boss Facer Screw (each)	7.99	SBF-5587S	x
Replacement Stud Boss Facer 3/8" Pilot (optional)	29.99	SBF-5587P	

BRAKE SERVICE TOOLING

MEASURING TOOLS

V-TWIN & METRIC HARD PARTS



Head Bolt Spot Facer

- Spot face head bolt seat parallel to new deck surface after angle milling
- Allows proper head bolt torquing
- Cutting tip radius matches OE design to avoid stress points and cracks • .468" shank with flat
- Use with 7/16" Pilot below
- High Speed Steel construction

Description	Jobber	Order No.
Spot Facer	\$157.99	HBF-15
7/16" Pilot	17.49	GFP-437

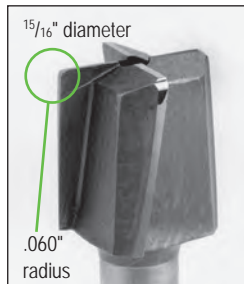

Mercedes .015" Head Saver Shims



- Shim cam towers if more than .015" is removed when resurfacing head
- Restores valve clearance & timing
- For 4, 5 & 6-cylinder Mercedes gas or diesel engines
- Each set shims all cam towers in one head
- Order No. **MHS-40** Jobber \$13.99



Smog Plugs

- Fit Ford 302 & 351
- Replace smog plugs damaged during head cleaning
- 5/8" x 11 thread outside, 7/16" x 14 thread inside
- Order No. **EMP-34**
- Jobber 1+ \$5.49 ea. Jobber 5+ \$4.94 ea.

Order 5 or more, SAVE 10% off Jobber



GM Vortec Adaptor Plate Set For Van Norman & Storm-Vulcan Rotary Broaches

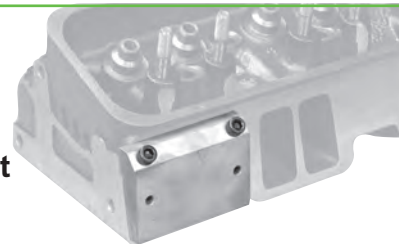

- Required when using the Van Norman VN 530 / 570 or Storm-Vulcan 850 Storm-Mill Rotary Broaches
- Two plate set • Includes fasteners
- Order No. **VN-VOR** Jobber \$62.99



Chevy Conversion Plate Set

- Convert early model, 6-bolt heads for late model, 7-bolt applications
- Works with stock exhaust systems
- Use the standard exhaust manifold gasket or seal with High-Temp Silicone
- Order No. **CHC-10** Jobber \$29.99

Parts Storage & Cleaning

dimensional
shipping

Organize, Clean And Store Small Parts With GOODSON Small Parts Baskets

- Galvanized, welded ¼" mesh
- Withstands most solvents
- Not for use in caustics



Small Basket with Lid

- 2½" dia. x 7" L
- Order No. **PWB-2** Jobber \$13.49

Medium Basket with Lid

- 4½" dia. x 7" L
- Order No. **PWB-4** Jobber \$15.49



Single Basket with Handle

- 8.75" OD x 8.5" H
- Lid & clip sold separately
- Order No. **PWB-10** Jobber \$16.49

Single Basket with Lid, Clip & Handle

- 8.75" OD x 8.5" H
- Order No. **PWB-15** Jobber \$26.99



Double Basket with Clip

- 8.75" OD
- 17" H
- Hinged on one side
- Order No. **PWB-25** Jobber \$27.99



Lid & Clip

- For PWB-10
- Order No. **PWB-10L** Jobber \$10.99

Clip Only

- Order No. **PWB-15C** Jobber \$4.49



Jet Wash Parts Basket Makes a 24" Circle

- Triangle-shaped • Sit side by side on Jet Wash table
- Fit more baskets in the machine to clean faster
- Order No. **JWB-6** Jobber \$119.99

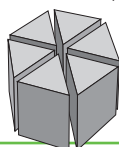
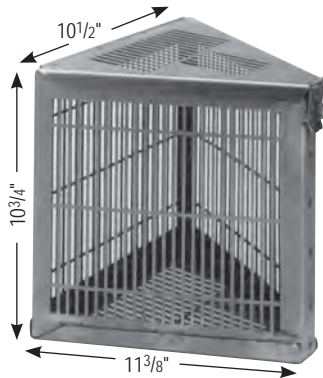

Six baskets fit in 24" diameter

Buy 3 and save 10% off jobber



BC-17



BC-15



BE-20

Engine & Parts Storage Bags

- Rugged, 3-mil thickness resists tearing
- Engine bags feature 4-mil thickness for extra strength
- Protects your professional work
- Waterproof • Protect finished work from damage
- Jumbo engine bags are extra-strong and big enough to fit complete engines
- Jumbo head bags fit the largest heads
- Ideal for storing heads, cranks, blocks, etc.

Description	Size	Thickness	Qty.	Jobber	Order No.
Heads, Cranks	16" x 37"	3-mil	100	\$69.99	BC-15
			10	10.99	BC-15-10PK
Jumbo Head	17" x 44"	3-mil	100	79.99	BC-17
			10	13.99	BC-17-10PK
Box-Style	27"x18"x36"	3-mil	50	77.99	BE-20
			10	17.99	BE-20-10PK
Jumbo Engine (Imprinted)	44" x 52"	4-mil	50	149.99	BE-44
			10	37.99	BE-44-10PK

Shrink Wrap

- Easy-to-use
- High-clarity film
- Keep machined surfaces clean
- Protects from dirt, dust and moisture
- No need to stock several bag sizes

Size	Jobber	Order No.
5" x 1000' w/ Extended Core	\$16.99	SW-5
18" x 1500' with 3" core	39.99	SW-18



Flock Lined Nitrile Parts Gloves

- Nitrile exterior with diamond grip pattern
- Flock lined • Won't swell • 13" long
- Safe for solvents • Sold as pairs

Size	Jobber	Order No.
Large	\$ 9.99	PWG-SOL-L
X-Large	12.99	PWG-SOL-XL
XX-Large	12.99	PWG-SOL-XXL

Get the Right Size Gloves

Size Inches
L 3.5" to 4.0"
XL 3.9" to 4.4"
XXL 5.0" to 5.5"



CYLINDER HEAD REBUILDING
CLEANING, ASSEMBLY & SAFETY
SHORT BLOCK REBUILDING
FLYWHEEL GRINDING
CRANKSHAFT/ FLYWHEEL GRINDING
MISCELLANEOUS TOOLS & SUPPLIES
BRAKE SERVICE TOOLING
MEASURING TOOLS
V-TWIN & METRIC HARD PARTS

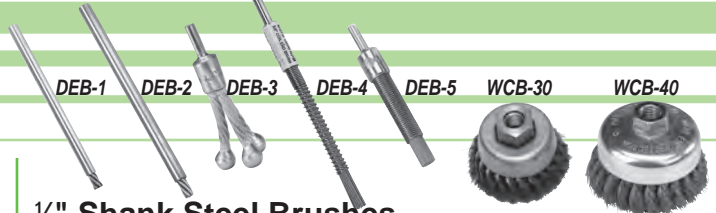

Steel End Brushes

Dia. / Wire gauge / Type	Jobber	Order No.
Standard Duty		
1/2" .020" crimped	\$ 8.99	GBC-4
3/4" .020" crimped	11.99	GBC-6
1" .020" crimped	12.99	GBC-10
1 1/2" .020" crimped	10.79	GBC-14
1 3/4" .012" crimped	14.99	NH-16
2 3/4" .012" crimped	17.99	NH-26
1 3/4" .014" galv. for alum.	10.79	ANH-16
2 3/4" .014" galv. for alum.	10.79	ANH-26
Ultra Duty (listed left to right)		
1/2" .014" crimped	\$ 8.99	GBC-4A
1 1/8" .020" knotted, 1 1/4"L	14.99	GBC-12
1 1/8" .020" knotted, 7/8"L	17.49	GBC-12HD
3/4" .020" knotted	12.99	NH-6

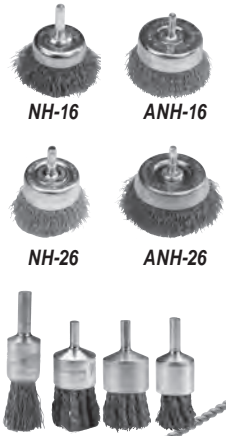

Engine Prep Brushes

Application	Jobber	Order No.
For small feed hole in block 1/4" x 2" x 10", nylon	\$6.49	OB-1
For Block Oil Return Line 5/16" x 2 1/2" x 12", nylon	6.49	OB-2
Like OB-2 but more flexible 5/16" x 2 1/2" x 12", nylon	6.49	OB-2A
For Block Oil Return Lines 3/8" x 2 1/2" x 12", nylon	6.49	OB-3
For diesel injector 1 3/4" brush, stainless	8.99	DIB-1
For lifter bores 1" x 3" x 14", nylon	9.99	LBB-100



Nylon Bristle Oil Gallery Brushes

Steel Wire Oil Gallery Brushes

Desc.	Jobber	Order No.
3-pc. Kit	\$18.99	OGB-SK ▼
1/4" x 3" x 24"	8.99	OGB-1 x
3/8" x 3" x 24"	9.99	OGB-2 x
5/8" x 3" x 24"	10.99	OGB-3 x

Desc.	Jobber	Order No.
5-pc. Kit	\$34.99	OGB-KIT ▼
3/8" x 3" x 34"	7.99	OGB-38 x
1/2" x 2 1/2" x 34"	7.99	OGB-42 x
5/8" x 3" x 34"	7.99	OGB-5 x
3/4" x 3" x 34"	8.99	OGB-7 x
3/4" x 3" x 40"	8.99	OGB-8 x

1/4" Shank Steel Brushes

Deep Well End Brush as brush wears cut back to expose new wire				
Dia.	Wire Gauge	Grade	Jobber	Order No.
1/4"	.012", 6" long	Economy	\$13.99	DEB-1
3/8"	.017", 6" long	Economy	16.99	DEB-2
Flare Brush use to remove carbon from engine ports				
1/2" ball, 5/16" cable		Ultra-duty	\$54.99	DEB-3
Port Brush as brush wears cut back spring for new wire				
3/8"	.014", 4" long	Standard	\$24.99	DEB-4
1/2"	.020", 2 1/2" long	Ultra-duty	23.99	DEB-5
Cup Brush 5/8"-11 NC - fits standard 4 1/2" angle grinder				
3"	.014" twisted	Ultra-duty	\$26.99	WCB-30
4"	.014" twisted	Ultra-duty	66.99	WCB-40

Order 10 or more brushes, (any combination) take 10% off jobber



Manual Guide Cleaning Brush

- 1/2" Dia. Nylon bristles
- OAL: 8 3/4"
- Order No. **WCB-44**
- Jobber \$4.49

Round Fiber Parts Brush

- 11" long • Nylon bristles
- Plastic Handle
- Order No. **PCB-348**
- Jobber \$8.99

Nylon Lifter Bore Brushes

Dia.	Job	Order No.
7/8"	\$8.99	LBB-875
1"	9.99	LBB-100
1 1/8"	9.49	LBB-1125

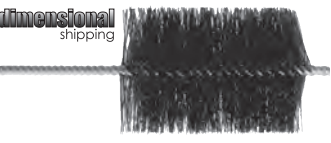

Nylon Bore Washing Brushes

Dia.	Length	Jobber	Order No.
2"	36"	\$21.99	CBB-200
2 1/4"	36"	22.99	CBB-225
2 1/2"	36"	23.99	CBB-250
2 3/4"	12"	21.99	CWB-27W
3 1/2"	18 1/2"	21.99	CWB-35
4"	18 1/2"	23.99	CWB-40
4 1/2"	18 1/2"	25.99	CWB-45
5"	18 1/2"	37.99	CWB-50

Flow Through Parts Washing Brush

- 24" long hose slides over discharge nozzle on parts washer
- Order No. **PWB-FLO-1**
- Jobber \$29.99



Nylon Pushrod Brush

- Clean the inside diameter of your pushrods with this brush
- Fits pushrods as small as .080" ID
- 12" overall length
- Order No. **PRB-80**
- Jobber \$15.99

5 Pc. Nylon Valve Guide Brush Set

- Complete set includes 5 popular nylon brush sizes
- From 3/16" to 1/2" dia.
- Order No. **GVP-SET**
- Jobber \$39.99

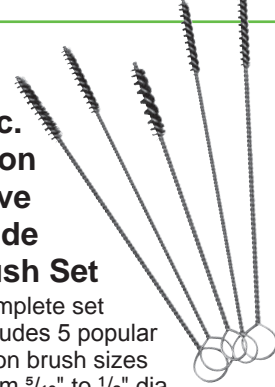

Valve Guide Brushes

Size	Steel Brushes		Nylon Brushes	
	OAL	Order No.	OAL	Order No.
5/16" x 2 1/2"	9 1/2"	GVP-1	12"	GVP-1N
1 1/2" x 2 1/2"	9 1/2"	GVP-2	12"	GVP-2N
3/8" x 2 1/2"	9 1/2"	GVP-3	12"	GVP-3N
7/16" x 2 1/2"	9 1/2"	GVP-4	12"	GVP-4N
1/2" x 2 1/2"	-----	-----	10 1/2"	GVP-5N
9/16" x 2 1/2"	-----	-----	10 1/2"	GVP-6N
3mm x 1 1/4"	-----	-----	8"	GVP-7N
4mm x 1 1/4"	-----	-----	8"	GVP-8N
5mm x 1 1/4"	-----	-----	8"	GVP-9N
6mm x 1 1/4"	8"	GVP-10S	8"	GVP-10N
7mm x 1 1/4"	8"	GVP-11S	8"	GVP-11N
Jobber ea.		\$9.99		\$7.99



Parts Cleaning



Order 10 or more brushes, (any combination) take 10% off jobber,



Radial Wire Brushes

- American made oil tempered high carbon steel wire
- High density for faster cleaning and longer life
- Excellent balance • 1/2" - 5/8" arbor

Size	Wire	Duty	Jobber	Order No.
6" x 1 3/16"	.014" Crimped	Std.	\$23.99	ADA-6
7" x 1/8"	.014" Crimped	Heavy	51.99	DA-7
6" x 3/16"	.016" Twisted	Super	26.99	TS-6
8" x 3/4"	.016" Twisted	Super	66.99	TS-8
6" x 7/16"	.023" Knotted	Ultra	39.99	QTC-6

Buy the Kit, SAVE!

BG-KIT

dimensional shipping

Engine Rebuild Brush Kit

- Includes the brushes you'll need for an average engine job
- A great starting place, then add more brushes as you need them • Replacement brushes available

Description	Jobber	Order No.
Standard Brush Kit - 10 Pc. Kit	\$64.99	BG-KIT
4" Nylon Cylinder Washing Brush	23.99	CWB-40
1 1/2" Nylon Valve Guide Brush	7.99	GVP-2N
3/8" Nylon Valve Guide Brush	7.99	GVP-3N
Lifter Bore Brush	9.99	LBB-100
Small Nylon Feed Hole Brush	6.49	OB-1
Block Oil Return Line Brush	6.49	OB-2
3/8" Oil Gallery Brush	7.99	OGB-38
1/2" Oil Gallery Brush	7.99	OGB-42
5/8" Oil Gallery Brush	7.99	OGB-5
Round Fiber Parts Brush	8.99	PCB-348

Disposable Assembly Wipes

- Blue, low lint wipes
- Pop-up box
- Hard-wearing
- Tear-resistant
- Ideal for a multitude of uses at the shop, at the track, even at home! • 100 per box
- Order No. **AW-100B**
- Jobber \$23.99



Super Scraper™

- Remove gaskets, carbon, rust, paint, etc.
- Precision-ground solid carbide-tipped, double-edged blade lasts longer than plain steel
- Nickel-chrome 1/8" thick steel shank • For all metals including aluminum

Width	Jobber	Order No.	Incl.
3 Pc. Set	\$107.99	SS-SET	▼
5/8"	29.99	SS-4U625	x
1 1/4"	36.99	SS-4U	x
2"	50.99	SS-4U2	x



Super Heavy Duty Double-Fill Cylinder Block Washing Brushes

- Highly aggressive
- Long lasting
- .050" Nylon bristles

Diameter	Jobber	Order No.
4" (101.6mm)	\$33.99	CWB-40DF
4 1/2" (114.3mm)	35.99	CWB-45DF

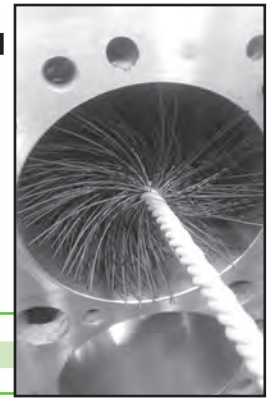

3M™ Roloc™ Bristle Discs

- Effective on cast iron, yet safe for aluminum
- Less aggressive than wire wheels
- Abrasive grains embedded in flexible plastic bristles that break down exposing new grain
- Bristles flex to maintain contact with contoured surfaces for faster, more thorough cleaning
- Use with holders below

Size	Color	Grit	Max. RPM	Jobber	Order No.
2"	Green	50	25,000	\$16.99	RBD-2G
	Yellow	80	25,000	15.49	RBD-2Y
	White	120	25,000	15.49	RBD-2W
3"	Green	50	18,000	21.99	RBD-3G
	Yellow	80	18,000	21.99	RBD-3Y

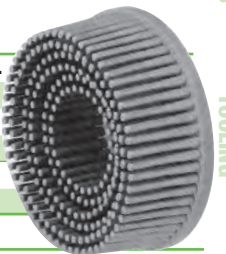

Nozzle

Water Shut-Off Valve

Hydro-Air Gun

- Hold by the air supply hose
- Use with hot or cold water
- The grip stays cool even when spraying hot water
- Maintenance free design
- Compact for reaching into tight areas
- Replacement parts available



Description	Jobber	Order No.
Hydro-Air Gun Assembly	\$107.99	BG-150
Replacement Water Shut-off	12.99	BG-150W
Replacement Nozzle	26.99	BG-150A

full service
...fast



"Did you know that Goodson still ships orders COD? If you prefer not to use a credit card or set up an open account, you can still order from Goodson. Ask us about COD."

- Pam, Goodson Accounting, 20 years of service

CYLINDER HEAD
REBUILDING

Goodson exclusive



Scan the code at right with your smart phone or other smart device for fast access to the product video on the Goodson website.

CLEANING,
SEMBLY & SAFETY

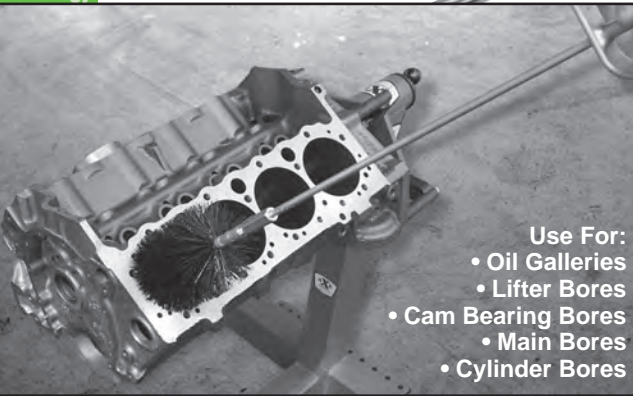

- Use For:
- Oil Galleries
 - Lifter Bores
 - Cam Bearing Bores
 - Main Bores
 - Cylinder Bores

Ergonomically designed grip made of billet aluminum

dimensional shipping

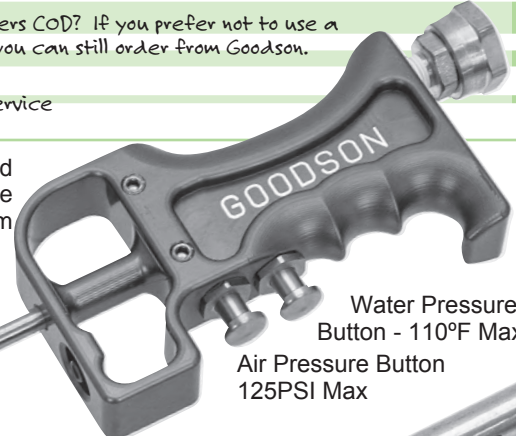

Water Pressure Button - 110°F Max
Air Pressure Button 125PSI Max

Stainless Steel wand will not corrode

Threaded to make brush changes quick and easy

Air/Water outlet holes are drilled in a spiral pattern to create a swirling motion to enhance the wand's cleaning power.

High Pressure Cleaning System

Aggressively clean oil galleries, lifter bores, cam bearing bores, main bores, cylinder bores and more

- Ergonomically designed pistol grip with easy to reach controls • Incorporates the aggressive cleaning action of a stainless steel or nylon brush with the hydro action of a specially designed water manifold to be used in conjunction with your shop air to quickly and easily clean the oil gallery holes in gas and diesel engines
- Stainless steel brushes are standard with the kits
- Do **NOT** use with caustics • 110°F max water temp.



Buy A Kit Or Create Your Own!

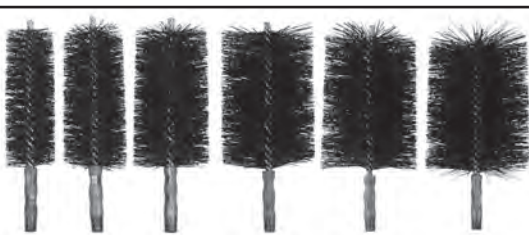
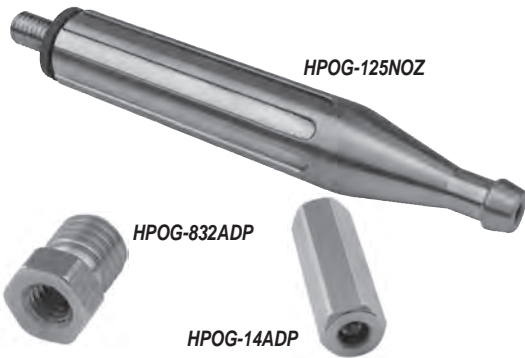

Description	Jobber	Order No.	Incl.
36" Cleaning Wand Kit	\$349.99	HPOG-1000	▼
18" Cleaning Wand Kit	339.99	HPOG-1018	▼
36" Cleaning Wand Assembly (wand, grip & brush adaptors)	339.99	HPOG-36	x
18" Cleaning Wand Assembly (wand, grip & brush adaptors)	289.99	HPOG-18	x
36" Cleaning Wand	65.99	HPOG-W36	
18" Cleaning Wand	53.99	HPOG-W18	
3/8" Stainless Steel Cleaning Brush	10.99	HPOG-375	x x
1/2" Stainless Steel Cleaning Brush	10.99	HPOG-500	x x
5/8" Stainless Steel Cleaning Brush	10.99	HPOG-625	x x
3/8" Nylon Cleaning Brush w/ 8-32 thread	8.99	HPOG-375N	
1/2" Nylon Cleaning Brush w/ 8-32 thread	8.99	HPOG-500N	
5/8" Nylon Cleaning Brush w/ 8-32 thread	8.99	HPOG-625N	
3/4" Nylon Cleaning Brush w/ 8-32 thread	8.99	HPOG-750N	
13/16" Nylon Cleaning Brush w/ 8-32 thread	8.99	HPOG-812N	
7/8" Nylon Cleaning Brush w/ 8-32 thread	8.99	HPOG-875N	
1" Nylon Cleaning Brush w/ 8-32 thread	8.99	HPOG-100N	
1 1/4" Nylon Cleaning Brush w/ 8-32 thread	8.99	HPOG-1125N	
8-32 Thread Adaptor	32.99	HPOG-832ADP	
2" Nylon Cleaning Brush w/ 1/4" pipe thread	32.99	HPOG-2000N	
2 1/4" Nylon Cleaning Brush w/ 1/4" pipe thread	32.99	HPOG-2250N	
2 1/2" Nylon Cleaning Brush w/ 1/4" pipe thread	34.99	HPOG-2500N	
3" Nylon Cleaning Brush w/ 1/4" pipe thread	35.99	HPOG-3000N	
3 1/2" Nylon Cleaning Brush w/ 1/4" pipe thread	36.99	HPOG-3500N	
4" Nylon Cleaning Brush w/ 1/4" pipe thread	36.99	HPOG-4000N	
4 1/2" Nylon Cleaning Brush w/ 1/4" pipe thread	37.99	HPOG-4500N	
5" Nylon Cleaning Brush w/ 1/4" pipe thread	37.99	HPOG-5000N	
1/4" Pipe Thread Adaptor	43.99	HPOG-14ADP	
1/4" Spray Nozzle	76.99	HPOG-125NOZ	

CRAN
FLYWHEEL

MISCELLANEOUS
TOOLS & SUPPLIES

BRAKE SERVICE
TOOLING

MEASURING
TOOLS

V-TWIN & METRIC
HARD PARTS



Defoaming Agent Stops Foaming In Coolants

- For jet washers, air-agitated hot tanks and coolant sumps
- Highly concentrated – start with 1 ounce in 50 gallons

Size	Jobber	Order No.
8 oz. / 236.6mL	\$12.79	D-FOAM-10
1 gallon / 3.78L	37.99	D-FOAM-128



Concentrated Hot Tank Detergent Powders For Cast Iron

- Strong alkaline • pH 12.8
- Removes dirt, heavy oil, grease, carbon, light rust and paint
- Mix ratio 1/2 lb. powder to 1 gal. of water
- 25 lbs.
- Order No. **D-Ci25** Jobber \$119.99

Hazardous Goods Fees Apply – Non-Returnable*



Micro Biostat

- Controls bacteria and fungus in coolant reservoirs
- Treat at 1 oz. per 5 gallons of capacity
- Operate machine for 30 minutes then empty the reservoir
- Refill with coolant and treat 1 oz. per 10 gallons
- Re-treat every 10 days to 2 weeks as needed so it can't happen again
- 16 oz. / 473.2mL bottle
- Order No. **GBP-20** Jobber \$48.99

Hazardous Goods Fees Apply – Non-Returnable*

Ultrasonic Cleaning Machine String Micron Filter

- Ensure your ultrasonic cleaning machine performs at its peak and delivers the clean your customers demand
- Available in 2 filtrations - 50 and 125 Microns **USCF-125**
- Measure 2.5" dia. x 10"L and will fit all standard 10" filter housing units
- High structural strength to stand up to severe operating conditions



String Micron Filters (2 1/2" x 10"L)

Filtration	Jobber	Order No.
125 microns (string)	\$17.99	USCF-125
50 microns (smooth)	17.99	USCF-50S

USCF-50S

Pro Jet Spray Cleaning Powder

- Heavy-duty • Non-caustic
- Penetrates to emulsify encrusted dirt, grease and oil on cast iron & aluminum
- Won't foam excessively
- Additives prevent scale build-up in jet spray components
- Use to maximum 165° F/ 73.9° C
- Mix ratio: 4 oz. powder to 1 gallon of water • pH: 12
- 40 lb. / 18.14 kg pail
- Order No. **PJS-50** Jobber \$179.99



Concentrated Hot Tank Detergent Powders For Non-Ferrous Parts

- Safe on aluminum & sensitive metals, rubber & plastic parts
- Removes heavy grease and oil
- 50 lb. pail • pH: 12.85
- Mix ratio: 1/4 lb. powder to 1 gallon of water
- Order No. **D-AL50** Jobber \$154.99

Hazardous Goods Fees Apply – Non-Returnable*

pH Test Strips

- Easy to use • 100 tests per package
- Use the handy guide on the box to determine pH between 0 and 14
- Order No. **HT-PH** Jobber \$46.99

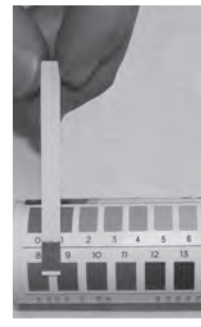

tech tips

from the techxperts™

Pay attention to the mix ratio on cleaning products!

It's important that you start mixing on the weak side and work your way up. An overly strong concentration is just as ineffective as an overly weak mixture. Use pH Test Strips to check the concentration.

Ultrasonic Detergents

- Safe for ferrous metals and aluminum
- Medium Duty can also be used on plastic
- For ultrasonic immersion tanks
- Medium Duty includes rust preventive
- 5 gallons / 18.99L containers



Formula	Mix Ratio	Uses	pH	Jobber	Order No
Water : Detergent					
Medium Duty	20 : 1	Metals, Plastics	11.6	\$189.99	USD-MD50
Heavy Duty	10 : 1	Metals, Aluminum	11.6	169.99	USD-HD50*

Hazardous Goods Fees Apply – Hazardous Items are Non-Returnable*

CYLINDER HEAD REBUILDING
CLEANING, ASSEMBLY & SAFETY
SHORT BLOCK REBUILDING
CRANKSHAFT/ FLYWHEEL GRINDING
MISCELLANEOUS TOOLS & SUPPLIES
BRAKE SERVICE TOOLING
MEASURING TOOLS
V-TWIN & METRIC HARD PARTS

... another satisfied customer

"Your service is excellent and it is very nice to be treated so well as a customer."
 — Steve, Kirby's Machining, Grover Beach, CA, Goodson customer since 1990

CYLINDER HEAD
REBUILDING

CLEANING,
ASSEMBLY & SAFETY

SHORT BLOCK
REBUILDING

CRANKSHAFT/
FLYWHEEL GRINDING

MISCELLANEOUS
TOOLS & SUPPLIES

BRAKE SERVICE
TOOLING

MEASURING
TOOLS

V-TWIN & METRIC
HARD PARTS

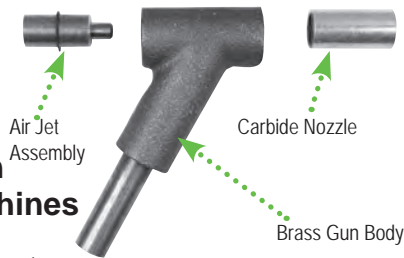

Glass Bead Gun for Smaller Machines

- Solid brass body
- Fits Trinco, Econoline, etc.
- Includes Gun Body, Nozzle and Air Jet Assembly
- Replacement parts available

Description	Jobber	Order No.
Complete Gun For Smaller Machines	\$117.99	GB-113
Replacement Parts		
Gun body only	\$67.99	GB-111
Carbide nozzle 19.05mm OD, 7.94mm ID	62.99	GB-204
Air jet assembly 3.97mm ID, 25 CFM	25.99	GB-330
Ceramic Nozzles (3 Pack) for GB-9 Glass Bead Gun	45.99	GB-9-NOZ

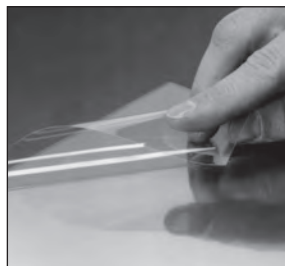

Glass Bead Cabinet Window Film

- Protects the inside of glass bead cabinet windows
- Save time and money – replace the film rather than the glass • 24" x 10' roll
- Order No. **GB-FILM**
Jobber \$21.99

tech tips

from the techxperts™

For best results, attach film to cabinet window with ordinary double-faced tape (not included).

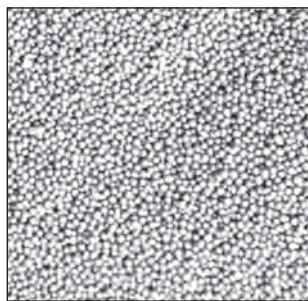

Glass Beads

- Clean parts thoroughly without removing material
- 50 lb. bag • Size #8
- Safe for ferrous & non-ferrous materials
- Order No. **GB-CM**
Jobber \$56.99



ARMEX® Maintenance XL Formula Soda Blast Cleaning Media

- 270 micron / 70 Grit Formula
- Use to strip clean almost any car surface including, steel, aluminum, Fiberglass® and plastics
- Ideal for blocks, heads and intake manifolds
- Dissolves in warm water, minimizing particle ingestion that can block fuel lines and passageways
- Won't damage the surface you're cleaning
- Non-toxic and non-hazardous with a pH of 8.2
- 50 lb. / 22.7 kg bags
- Order No. **SMB-170** Jobber \$39.99

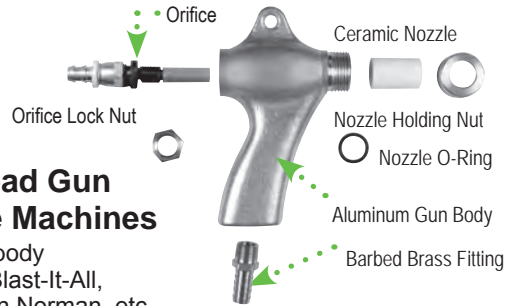

Glass Bead Gun for Large Machines

- Aluminum body
- Fits Zero, Blast-It-All, Winona Van Norman, etc.
- Includes .313" ID ceramic nozzle

Description	Jobber	Order No.
Complete Gun For Larger Machines	\$157.99	GB-100
Replacement Parts		
Gun body only	\$92.99	GB-101
Barbed Brass fitting	9.99	GB-04
Nozzle holding nut (not included in kit)	17.49	GB-54

Rebuild Kits	Jobber	Order No.	Includes
.250" ID	\$64.99	GB-4-OK	▼
.313" ID	64.99	GB-5-OK	▼
.375" ID	64.99	GB-6-OK	▼
.437" ID	74.99	GB-7-OK	▼
Ceramic Nozzles .250" ID	25.99	GB-74	x
7/8" OD x 1 3/8" .313" ID	25.99	GB-75	x
.375" ID	25.99	GB-76	x
.437" ID	31.99	GB-77	x
Replacement Orifices	51.99	GB-64	x
	51.99	GB-65	x
	51.99	GB-66	x
	51.99	GB-67	x
Orifice Lock Nut	10.79	GB-52	x x x x
O-Ring	7.99	GB-53	x x x x



Glass Bead Gloves

- 30" overall length
- For ports up to 10" diameter
- Durable cloth-lined Neoprene glove with nylon sleeve
- Sleeve design makes attaching glove to your machine, faster and easier • Clamp sold separately

Port Size	Description	Jobber	Order No.
Up to 8" (20.32 cm)	Single: left-hand glove	\$36.99	GB-654-G
	Single: right-hand glove	36.99	GB-655-G
	Pair: one right-hand & one left-hand	66.99	GB-660-G
Up to 10" (25.4 cm)	Single: left-hand glove	45.99	GB-754-G
	Single: right-hand glove	45.99	GB-755-G
	Pair: one right-hand & one left-hand	87.99	GB-770-G
8" and 10"	Replacement Clamp: fits both port sizes	10.79	GB-CLAMP

SAFETY TIP: NEVER point the Glass Bead Gun at the cabinet window or your co-workers!

Cleaning Media

For Parts Tumblers



Ceramic Diagonals (20 lb.)
For soft materials such as brass and aluminum. $\frac{5}{16}$ " dia., $\frac{5}{8}$ " long
Order No. **PTM-20CR** Jobber \$79.99



Steel Diagonals (20 lb.)
Ideal for valves.
 $\frac{5}{16}$ " dia., $\frac{5}{8}$ " long
Order No. **PTM-20D** Jobber \$249.99

For Airless Blasters

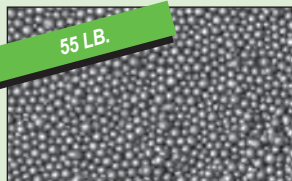

Steel Shot, 170 grade (55 lb.)
Ideal for cleaning cast iron heads.
Diameter varies from .017" to .024".
Order No. **SS-CM** Jobber \$86.99

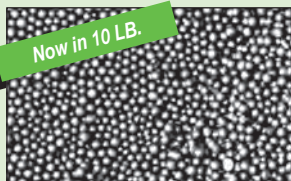

Stainless Steel Shot, Conditioned.
Clean aluminum heads to look like new.
Restores bright aluminum finish. Lasts longer than plain carbon steel shot.
Diameter varies from .006" to .016".
10 lb.
Order No. **SS-CS10** Jobber \$74.99

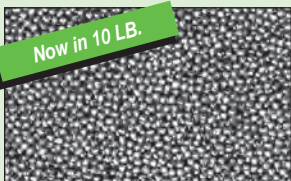

Stainless Steel Cut Wire Shot
Unconditioned. Clean cast iron or aluminum heads before and normalize after welding. Helps prevent surface corrosion after blasting.
.020" Diameter. 10 lb.
Order No. **SS-CW10** Jobber \$119.99

Heat Resistant Gloves, p. 97



Hot Tank Gloves

- One size fits most
- Sold in pairs
- Neoprene fully coated with knit lining
- Shoulder length features eyelets & strings at tops to prevent slipping

Description	Jobber	Order No.
Gauntlet Length (14" long)	\$26.99	HTG-200
Elbow Length (18 $\frac{1}{2}$ " long)	38.99	HTG-200E
Shoulder Length (34 $\frac{1}{2}$ " long)	74.99	HTG-200L

Full Length Neoprene Shop Apron

- Protects from caustics, steam, grease and oil
- Bib-style • 35" x 45"
- Order No. **HTA-300**
Jobber \$33.99

Shown with Shoulder Length Hot Tank Gloves (above)



Cloth Shop Apron

- Bib-style apron
- Heavy duty black fabric
- Several handy pockets
- Embroidered Goodson Racing logo
- Machine Washable
- Order No. **CA-100**
Jobber \$36.99



See Pages 132 for Keepers

Keeper-Keeper

- Screws closed tightly
- $\frac{1}{4}$ " holes
- Ideal for tumbling keepers
- Solvent resistant PVC
- Order No. **VK-15**
Jobber \$17.99

See Page 137 for Valve Stems

Valve Stem Protectors

- Protects against parts tumbler damage
- Slips on and off easily
- 16 per package
- Order No. **VSP-16**
Jobber \$13.99



Parts Tumbler Solution

- Dilute 30:1 with water
- For best results, dry parts with compressed air • 1 gallon / 3.78L
- Order No. **PT-SOL**
Jobber \$14.99

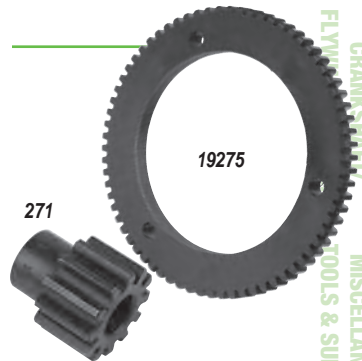

Replacement Gears For Sioux™ 710 Parts Tumbler

- Replaces discontinued Sioux™ parts

Description	Jobber	Order No.
Steel Gear	\$74.99	271
Fiber Gear	71.99	19275



Steel Parts Tumbler Basket

- Fits Goodson, K.I., Axe, RMC, and Peterson
- 8" x 12" x 12"
- Order No. **PT-BASKET**
Jobber \$429.99

CYLINDER HEAD REBUILDING

CLEANING, ASSEMBLY & SAFETY

SHORT BLOCK REBUILDING

FLYING

CRANKSHAFT/ TOOLS & SUPPLIES

MISCELLANEOUS TOOLING

MEASURING TOOLS

BRAKE SERVICE

V-TWIN & METRIC HARD PARTS

... another satisfied customer

"I enjoy doing business with Goodson. The website is easy to navigate and to pay for purchases. Package arrived in a timely manner."

- Jim Meis, Elgin, NE, Goodson customer since 2018

CYLINDER HEAD REBUILDING

Mix or Match to SAVE!

Order 12 or more cans, save 10% off Jobber



Last Blast Spray Paint

- Quick-dry formula lets you handle parts in minutes
- Pigment won't smudge AND resist abrasion, corrosion and most solvents
- Paint heads, blocks and parts just like OE
- Withstands heat up to 250°F/121.1°C
- 12 oz. cans
- **Last Blast** restores an original look to all types of cast iron
- **Aluminum Last Blast** makes aluminum heads and parts look new
- **Color Last Blast** paint heads and parts in popular, factory colors
- **Hi-Temp Last Blast** Withstands continuous heat up to 1200°F. Heat at 450°F for 1 hour to create a professional, durable finish

Color	Jobber 1+	Jobber 12+	Order No.
Cast Iron Gray	\$8.29	\$7.46	LB-1*
Aluminum Gray	8.29	7.46	ALB-1*
GM Black (Gloss)	8.49	7.46	CLB-58*
Ford Blue	8.99	8.09	CLB-61*
Chevy Orange	8.99	8.09	CLB-61*
Hi-Temp Cast Iron Gray	8.99	8.09	LB-1-HT*
Hi-Temp Aluminum Gray	8.99	8.09	ALB-1-HT*
Hi-Temp Black (Matte)	8.99	8.09	CLB-58-HT*

Mix or Match Quantities to SAVE! Order 12 cans, save 10% off Jobber

*Aerosol — Hazardous Goods Fees Apply When Shipped By Air



CLEANING, ASSEMBLY & SAFETY

SHORT BLOCK REBUILDING

CRANKSHAFT/ FLYWHEEL GRINDING

MISCELLANEOUS TOOLS & SUPPLIES

TOOLING

MEASURING TOOLS

V-TWIN & METRIC HARD PARTS

Industrial Metal Markers

- No shaking needed • Quick dry
- Withstands oil, grease & surface contact • Won't lose its brilliance or legibility
- Medium point



Color	Jobber 1+	Jobber 5+	Order No.
Orange	\$7.49	\$6.74	MM-STD
Black	7.49	6.74	MM-010
Yellow	7.49	6.74	MM-030
White	7.49	6.74	MM-050
Green	7.49	6.74	MM-060
Red	7.49	6.74	MM-070
Blue	7.49	6.74	MM-080

Mix or Match Quantities to SAVE! Order 5 or more, save 10% off Jobber

Universal Gel Lube

- Sprays on as a liquid and forms into a gel within seconds
- Penetrating formula blends with motor oil
- Multiple uses, including cams, lifters, rocker arms, bearings, pistons/wrist pins, cylinders, valve springs, etc.
- Provides lubrication for engines subjected to prolonged storage before initial start-up
- 8 oz. Aerosol* can
- Order No. **GL-8U**
- Jobber 1+ \$21.99 ea.
- Jobber 6+ \$19.79 ea.

Order 6 or more, Save 10% off jobber



*Hazardous Goods Fees Will Apply if Shipped By Air

2" Dispensing Pliers for Flexible Tubes

- Maximizes the use of all the material in the tube due to its effective means of application
- Dispenses the thickest sealant through a very small opening, permitting better application control
- Reduces both cleanup time and the possibility of skin contact or other problems caused by excess material squeeze-out
- Order No. **EB-416** Jobber \$22.99



High-Performance Hylomar® Gasket Maker & Thread Sealer



- Maintains seal integrity up to 600°F / 315.5°C
- Polyol-based compound turns from a gel into flexible putty within minutes of application
- Non-hardening formula is impervious to oil, gasoline, glycol and other engine fluids
- Oxygen-sensor safe
- Seals gaps .01" or less
- 100 gram tube
- Order No. **HBS-1** Jobber \$29.99



Assembly & Break-In

Order 6 or more, Save 10% off jobber 

Press Fit Lube

- A light coat eases press fit
- Ideal for valve guides, piston pins, cylinder sleeves, etc.
- Eliminates the scoring, gouging and galling of parts during press fitting
- 6 oz. / 177.4mL • Aerosol*
- Order No. **PFL-200**
Jobber 1+ \$13.99 ea.
Jobber 6+ \$12.59 ea.

*Hazardous Goods Fees Apply When Shipped By Air



Press Fit Lubricant

- A light coat eases press fit
- Multiple applications
- Eliminates scoring, gouging and galling of parts during press fitting

Description	Jobber	Order No.
Aerosol 7 oz. / 207 mL	\$21.27	B-200*
Brush Applicator 200 mL	28.93	B-200L

*Hazardous Goods Fees Apply When Shipping By Air



Extreme Pressure Lube

- Withstands pressures up to 50,000 PSI
- Highly refined petroleum product
- Contains no lead, graphite or minerals
- Won't corrode fine surfaces or emulsify with cooling liquids
- Surfaces stay lubed and protected
- In a grease form • 4 fl. oz. / 118.29mL
- Order No. **EPL-4** Jobber \$13.49

Order 6 or more, Save 10% off jobber 

Spray Assembly Lube

- Ideal for lubricating parts to ease assembly
- Eliminates critical initial run-in of new and rebuilt high-performance engine components
- Spray on bearings, crankshafts, pistons, rings, etc.
- 11 oz. Aerosol* can • Order No. **SAL-11**
Jobber 1+ \$15.99 ea.
Jobber 6+ \$14.39 ea.

*Hazardous Goods Fees Apply If Shipped By Air



First Lube Engine Assembly Lube

- Prevent dry engine start-ups after long-term storage
- Contains Zinc and Moly
- Clings and forms a slick wall between moving parts
- Withstands start-up pressure
- Compatible with all motor oils

Size	Jobber	Order No.
8 oz. / 236.6mL	\$ 7.99	FL-10
1 gallon / 3.78L	41.99	FL-128



Blood Friction Master® Engine Assembly Lube

- Contains a low friction additive (PTFE) for dry start-ups
- Ideal for long-term storage
- Forms a slick wall between moving parts
- Clings until dissolved by oil
- Withstands start-up pressure
- Compatible with all motor oils
- Ideal for high performance

Size	Jobber	Order No.
8 oz./236.6 mL w/brush	\$ 15.99	AL-22-8
1 gal./3.78 L w/pump	144.99	AL-22-10



Need Zinc?

Cam-Shield® Camshaft Assembly Paste

- Provides anti-wear protection for camshafts during break-in
- 2500 parts per million of Zinc
- Use with mechanical and hydraulic camshafts & lifters
- For racing, street, classic, agricultural, diesel & marine camshafts
- 4 oz. / 118.29 mL Brush Top Jar
- Order No. **CSAP-4** Jobber \$19.99



Mr. Race Oil® Engine Assembly Gel

- For all 4-stroke engines!
- An advanced engine assembly gel designed to stay in place for engine protection during storage, shipping and start-up time
- Petroleum based, oil soluble product
- Colored blue so you can see where it's applied
- 8 ounce jar • Order No. **EAG-8** Jobber \$38.99



CYLINDER HEAD REBUILDING
CLEANING, ASSEMBLY & SAFETY
SHORT BLOCK REBUILDING
FLYWHEEL GRINDING
CRANKSHAFT/FLYWHEEL GRINDING
MISCELLANEOUS TOOLS & SUPPLIES
BRAKE SERVICE TOOLING
MEASURING TOOLS
V-TWIN & METRIC HARD PARTS



Rust Proofing Oil

- 1 Gallon / 3.78 L
- Apply full strength
- Creates a protective film
- Washes off with standard solvents
- Brush or spray on
- Order No. **RPO-10** Jobber \$129.99

Order 6 or more cans
save 10% off jobber



Rust Shield

- Non-sticky
 - Lasts several weeks
 - Wipe off with a towel
 - 12 oz. Aerosol* can
 - Order No. **RS-16**
- Jobber \$14.99 ea.
Jobber 6+ \$13.49 ea.
*Hazardous Fees Apply If Shipped By Air



Rust Shield for Shop Equipment

- Stops rust without causing rancidity
- Apply to machine parts such as ways
- Mixes with coolant – no need to remove before machining
- 1 Gallon / 3.78 L
- Order No. **RS-128** Jobber \$29.99



Petroleum Based Rust Inhibitor

- Brush directly from can onto freshly-machined engine components
- Protects iron, steel and aluminum
- Soften with mineral oil to dip small parts

Quantity	Jobber	Order No.
2 lbs.	\$ 34.99	RPC-2A
35 lbs.	419.99	RPC-35A



Snap Together Adjustable Coolant Hoses

- Hoses hold any shape • Chemical Resistant
- Ideal for most common shop machines

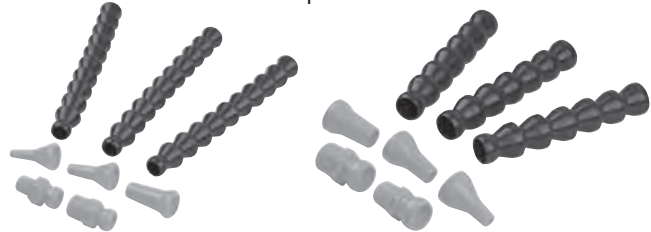

Size: 1/4" Hose Kit
Includes: 18" hose, 1/4" & 1/8" NPT fittings, 1/16", 1/8" & 1/4" round nozzles

Application: Most parts washers, wet-type seat grinders, valve refacers

Order No.: **ACH-400** Jobber \$20.99

Size: 1/2" Hose Kit
Includes: 16 1/2" hose, 3/8" & 1/2" NPT fittings, 1/4", 3/8" & 1/2" round nozzles

Application: Most cylinder hones and flywheel grinders

Order No.: **ACH-600** Jobber \$24.99



Universal Coolant Magnet

- Ideal for Honing Tanks, Flywheel Grinders, Crankshaft Grinders, Head Surfacers and more
- Prevents metal swarf from passing into the coolant tank
- Cut or shape to fit machine bases and return ways
- Measures 3"x48" • Can be trimmed to any size needed
- Order No. **UCM-348** Jobber \$26.99

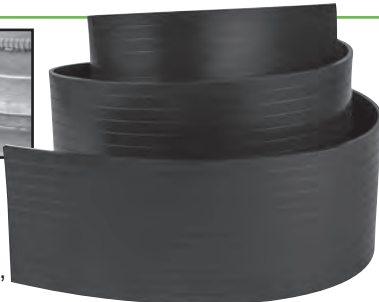

Size: 1" Flare Nozzle for 1/4" Hose

Order No.: **ACH-407**
Jobber \$9.99



Size: 1 1/4" Flare Nozzle for 1/2" Hose

Order No.: **ACH-807**
Jobber \$11.99

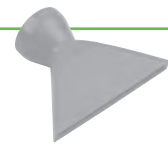

Size: 2 1/2" Flare Nozzle for 1/2" Hose

Order No.: **ACH-809**
Jobber \$13.99



NPT	Hose ID	Jobber	Order No.
1/4"	1/4"	\$ 8.99	ACH-406
3/8"	1/2"	11.99	ACH-804
1/2"	1/2"	8.99	ACH-805

Hose ID	Lng.	Jobber	Order No.
1/4"	11"	\$14.99	ACH-401
1/2"	11"	13.99	ACH-801

Coolant & Solvent Pumps

Ideal for Parts Washers

Ideal for Flywheel Grinders

170 Gal. Per Hour Pump

- HP: 1/125
- Capacity: 170 gal/hr. at 1" depth • Hi-temp Seals
- Voltage: 115
- Size: 4" x 3 1/4" x 2 3/4"
- Order No. **COP-166** Jobber \$159.99



1200 Gal. Per Hour Pump

- HP: 1/6
- Capacity: 1200 gal/hr. at 1" depth
- Voltage: 115
- Size: 7 3/4" x 6 1/8" x 4 5/16"
- Order No. **COP-1833** Jobber \$204.99



Sludge Filter Bag

- Fits any machine with a coolant sump
- Replace costly OE filters with this economical, universal sock
- Adds filtration to machines that don't have enough • 8" x 24" polyester knit sock
- Order No. **SB-1** Jobber \$10.79



The best engine pre-lube tank in the industry!

CYLINDER HEAD REBUILDING
CLEANING, ASSEMBLY & SAFETY
SHORT BLOCK REBUILDING
FLYWHEEL GRINDING
CRANKSHAFT/ TOOLS & SUPPLIES
MISCELLANEOUS TOOLS & SUPPLIES
BRAKE SERVICE TOOLING
MEASURING TOOLS
V-TWIN & METRIC HARD PARTS



made in america



Improved ON/Off Ball Valve



Built-in pressure gauge shows tank pressure



Patent-pending Filler Cap. Designed to safely release any pressure left in tank after draining.

10 Quart Engine Pre-Lube Tank

- 10 quart capacity is big enough for all but monster engines
- Corrosion-resistant aluminum tank eliminates contamination from rust
- Large 1 3/4" diameter filler hole lets you pour oil right from the bottle - no funnel required
- Includes 3 fittings (1/4"x1/4", 1/4"x1/8" and GM LS-1)
- Replacement Parts available

Description	Jobber	Order No.
10 Quart Pre-Lube Tank	\$299.99	EPL-110
Replacement 8' Hose	45.99	EPL-HOSE
LS1 Fitting	32.99	EPL-LS1
1/4" Replacement Fitting	5.49	EPL-14
1/8" Replacement Fitting	6.49	EPL-18
Replacement Gauge	13.99	EPL-CG
Mini Ball Valve	26.99	EPL-MBV



8' long, 1/4" diameter hose gives you lots of length to work with



Replacement PF Filter Cartridges

- Cartridges remove grit, metal and dirt from honing oil
- Fit Sunnen® CK-10, CV-616, LBB-1810, PF-150 and CH-100 honing machines



Description	Application	Qty.	Jobber	Order No.
Extra Fine	Oil Only	4 Pk.	\$222.64	PF-105-4
Fine	Oil Only	4 Pk.	222.64	PF-110-4
Extra Fine	Water Only	1 Pk.	161.22	PF-104
Fine (Fiberglass)	Water Only	1 Pk.	158.92	PF-160

1" Thick Rod Hone Filter Mat

- Synthetic material
- Traps abrasive particles & metal filings BEFORE they enter the storage tank
- Cushions parts to prevent damage
- Replace when clogged
- 1" (25.4mm) thick

Inches	Metric	Jobber	Order No.
18" x 25"	45.7 x 63.5 cm	\$17.99	RH-MAT
26" x 40"	66.0 x 101.6 cm	26.99	RH-MAT-2
33" x 48"	83.8 x 121.9 cm	27.99	RH-MAT-3

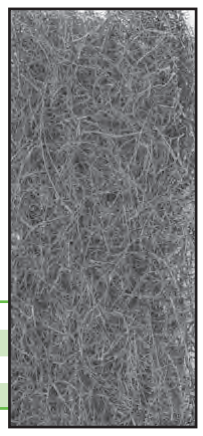

Machine Capacities		
Mfr.	Machine	Capacity
Sunnen	LBB-1699	15 Gal.
	LBB-1660	15 Gal.
	LBB-1810	25 Gal.
	LBB-1803	25 Gal.
	EC-3500	32 Gal.
	ML-3500	32 Gal.
	ML-5000	32 Gal.
	ML-2000	28 Gal.
	CK-10	55 Gal.
	CV-616	55 Gal.
SV-10	55 Gal.	
CK-21	63.5 Gal.	

Machine Capacities		
Mfr.	Machine	Capacity
Rottler	H85AXY	70 Gal.
	H85A	70 Gal.
	H85AX	70 Gal.
	H86A	70 Gal.
	H86AX	70 Gal.
	H86AXY	70 Gal.

tech tips
from the techxperts™

Hone Cabinet Filter Paper

- Reduce sump and filter clean-up
- Extend oil life
- Filter paper in the bottom of hone machine removes debris before oil enters the sump
- When full, dispose of properly
- 2 - 60" x 60" sheets (trim to fit)
- Order No. **HN-FP** Jobber \$21.99

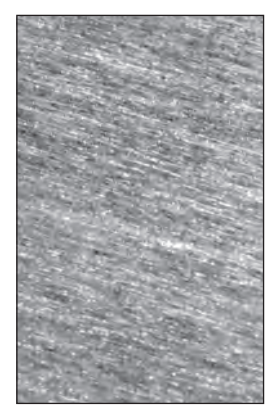



Coolants and Lubricants

We don't stock one type of coolant and claim that it suits all types of grinding, nor do we carry one type of oil and try to sell it for every application. Each of our coolants, lubricants and oils is formulated to deliver better results and longevity in its specific use. All of our coolants prolong the life of grinding wheels, retard corrosion and rancidity. Colors may vary. **Note: Dilution ratio is water to coolant.**

Grinding Coolants

All-Purpose Grinding Coolant

A synthetic water soluble coolant that "Licks Rust". Dilute 30:1

Size	Yield	Jobber	Order No.
1 gal.(3.78L)	30 gallons	\$ 34.99	CGC-1288
5 gal.(18.9L)	150 gallons	167.99	CGC-5288

Crank & Cam Grinding Coolant

Synthetic, non-nitrate, high lubricity coolant. Dilute 20:1

Size	Yield	Jobber	Order No.
1 gal.(3.78L)	20 gallons	\$ 36.99	CGC-10
5 gal.(18.9L)	100 gallons	159.99	CGC-50

Multi-Duty Grinding Coolant

Medium-duty, low foaming, synthetic coolant with rust inhibitors. Safe for ferrous and non-ferrous metals alike. No nitrates, phenols, chlorine or sulfur. Dilute 30:1

Size	Yield	Jobber	Order No.
1 gal.(3.78L)	30 gallons	\$ 43.99	GPC-10
5 gal.(18.9L)	150 gallons	214.99	GPC-50

Belt-Resurfacing Coolant

For all belt-type resurfacers with or without down-pressure. Dilute 30:1

Size	Yield	Jobber	Order No.
1 gal.(3.78L)	30 gallons	\$ 47.99	SGB-10
5 gal.(18.9L)	150 gallons	229.99	SGB-50

Surface Grinding Coolant

Non-foaming, non-nitrate coolant for single-piece resurfacing wheels or segments. Dilute 20:1

Size	Yield	Jobber	Order No.
1 gal.(3.78L)	20 gallons	\$ 32.99	SGC-10
5 gal.(18.9L)	100 gallons	149.99	SGC-50

Flywheel Grinding Coolant

Includes a synthetic rust inhibitor that prevents rancidity. For all flywheel grinders. Dilute 30:1

Size	Yield	Jobber	Order No.
1 gal.(3.78L)	30 gallons	\$ 44.99	FG-1101-G
5 gal.(18.9L)	150 gallons	159.99	FG-1102-G

Grinding & Honing Oils (Not Water Soluble)

Cylinder Honing Oil (Clear)

Ideal for portable hones and all makes of automotive honing machines. Mixes readily with other brands (including Sunnen®).

Size	Jobber	Order No.
1 gal.(3.78L)	\$ 26.99	HO-10
5 gal.(18.9L)	124.99	HO-50
55 gallons	1399.99	HO-550



Sunnen® Mineral Based Honing Oil

Formulated for general purpose automotive machine shop honing. Compatible with most popular honing machines.

Size	Jobber	Order No.
5 gal. (18.9L)	\$172.97	MAN-845



Valve Grinding Oil (Light Yellow)

Universal valve grinding oil extends wheel life. Mineral based. Prevents rancidity, foaming & deposits.

Size	Jobber	Order No.
1 gal.(3.78L)	\$ 39.99	VGO-10
5 gal.(18.9L)	169.99	VGO-50



Rod Honing Oil (Dark Brown)

Keeps stones clean & free-cutting during rod reconditioning, pin fitting and other honing jobs. Will mix with other brands (including Sunnen®).

Size	Jobber	Order No.
1 gal.(3.78L)	\$ 38.99	RHO-10
5 gal.(18.9L)	189.99	RHO-50



Sunnen® Honing Oil Concentrate

Formulated for general purpose automotive machine shop honing. Compatible with most popular honing machines. Add your own Mineral Oil. Mix Ratio: 10:1 for MAN-845 or 2:1 for MB-30

Size	Jobber	Order No.
5 gal. (18.9L)	\$294.68	MAN-C



Severe Duty Valve Grinding Oil (Brown)

For grinding titanium, Inconel®, stainless steel and stellite valves. Includes additives to improve cutting performance under pressure.

Size	Jobber	Order No.
1 gal.(3.78L)	\$ 44.99	VGO-SD10
5 gal.(18.9L)	194.99	VGO-SD50



Diamond Honing Oil (Brown)

Specially formulated to withstand the cutting pressures created when using our Diamond Valve Guide Honing System.

Size	Jobber	Order No.
8 oz.(236.6mL)	\$ 5.99	DHO-8
1 gal.(3.78L)	42.99	DHO-10
5 gal.(18.9L)	189.99	DHO-50



Sunnen® Mineral Based Multi-Purpose Honing Oil

High performance lubricity agents with sulfur extreme-pressure additives. Won't weld or tear the work-piece. For metals from aluminum to zirconium

Size	Jobber	Order No.
5 gal. (18.9L)	\$190.16	MB-30



Titanium Valve Grinding Aid

Mix ratio of 1:4. Add to mineral based valve grinding oils. Improves finish on titanium, stainless steel and stellite valves.

Size	Jobber	Order No.
32 oz.(946.6mL)	\$51.99	VGA-T32



Machine Lubricants

Flywheel Grinder Table Lubricant

Helps extend flywheel grinder life. This high-pressure oil is designed to lubricate table bearings and ways. For all makes of flywheel grinders.

Size	Jobber	Order No.
1 gal.(3.78L)	\$43.99	FG-1131-G



Way Oil

Adhesive oil formulated to provide extended lubrication and rust protection for machine-tool ways.

Size	Jobber	Order No.
1 gal.(3.78L)	\$32.99	WO-50



Rust Shield for Shop Equipment

Prevents rust and won't cause rancidity. Protective film mixes with coolant so you don't have to clean it off before using the machine.

Size	Jobber	Order No.
1 gal.(3.78L)	\$29.99	RS-128



3-D Fast Cut™

3-D Fast Cut™ Starter Kits	8, 9
Ball Head Drive Adaptors	8, 9
Bounce Springs	8, 9
Bowl Profiler	14
Lift Clip.....	4, 8, 14
Micro Ball Head Tooling	9, 11, 14
Pilots.....	5 - 7
Setting Micrometer	3, 9
Tool Setting Fixture	8, 9
Universal Spring Pad Cutters	14
Valve Seat Cutter Blades	10 - 13
Valve Seat Cutter Tool Holder.....	8, 9
Valve Seat Removal Tooling.....	9

A

Abrasive Belt Dresser	109
------------------------------------	-----

Abrasives

Aluminum Oxide Cloth Shop Rolls	61
Belts.....	51, 110, 111
Bench Grinder Wheels	118
Blanchard Cylinders	53
Brake Drum Grinding Wheels.....	123
Brake Shoe Grinding Sleeves	124
Cam Grinding Wheels	103
Cartridge Rolls	60, 61
CBN Inserts for Cast Iron	50
Chamfering Cones.....	48, 91
Crankshaft Grinding Wheels.....	4, 104, 105
Crankshaft Polishing Belts.....	110, 111
Crocus Cloth	61
Cross Buffs®	60, 61
Cylinder Head Resurfacing.....	50 - 53
Cylinder Honing.....	88 - 94
Diamond Honing.....	34
Diesel Super Abrasive Insert.....	50
Discs.....	61
Flapwheels	60, 61
Flex-Hones®.....	36, 85, 91, 103, 124
Flywheel	114 - 115
Grinding Discs	61
Grinding Wheels .28, 29, 53, 93, 103, 105, 118	
Grinding Stones.....	20 - 25, 114, 115
Honing	34, 36, 85, 88 - 94
Hyper-Finish Diamond Honing	34
Lifter Bore Honing.....	101
Mounted Points.....	60, 62
PCD Inserts for Aluminum	50
Rod & Cap Grinding Wheels	93
Rod Honing / Pin Fitting.....	92 - 93
Sleeves.....	60, 124
Ultra-Finish Plateau Honing.....	39, 90, 94
Valve Guide Honing.....	34, 36
Valve Refacing	28, 29
Valve Seat	20 - 25

Accu-Turn

Replacement Cutting Tips	119
Replacement Parts.....	123

Adjustable Coolant Hoses	74
---------------------------------------	----

Adjustable Counterbore Cutter Kit	17
------------------------------------------------	----

Aircraft Seat Grinding Tools	25
-------------------------------------------	----

Air Tools	19, 35, 36, 42, 43, 45
Align Hone Mandrels & Stones	94
All Tool Brake Lathe Replacement Tips	119
Aluminum Last Blast	72
Alumni-Chek	55
Ammco	
Belts, Drive	124
Brake Lathe Arbor	122
Brake Lathe Cutting Tips	119
Replacement Parts	122 - 124
Aprons	71, 138
Arbor Nuts	122
Arbors	122
Assembly Lubes	72, 73
Assembly Wipes	67
Aviation Seat Grinding Tools	25

B

Bags	65
Balancing Scales	113
Ball Head Seat Cutter Driver	8, 9
Ball Hones	34, 85, 91, 103, 124
Band Ring Compressors & Expanders	97
Baskets	65, 71
Beehive Springs	133, 134
Beeswax	102
Bean Brake Lathe Replacement Tips	119
Bearing Scraper	102
Bell Clamps	123
Belt Dressers	109
Belts	
Crankshaft Polishing.....	110, 111
Cylinder Head Resurfacing.....	51
Kwik-Way Valve Refacer Belts	31
Oil Pump Belts.....	92
Rod Honing Belts (for Sunnen).....	92
Sioux Replacement Belts	30
Sunnen® Honing Machine Belts.....	92
Surface Grinding Belts.....	51
Bench Grinder Wheels	118
Bifocal Safety Glasses	62
Black & Decker	
Adaptor for Sioux Stones	24
Replacement Collet	30
Stone Holders & Accessories	24
Valve Refacer Wheels	28
Black Diamond Valves	137
Black Diamond Valve Guide Sizing	34
Black Light	55, 57, 118
Black Smoke Series Cutters	13
Blanchard Grinder Wheel	53
Block Bags	65
Blood Friction Master® Assembly Lube	73
Bluing Fluid	15
Bore Gauges and Stands	127, 128
Boring Bar Cutters/Accessories	86, 87
Bounce Springs	8, 9, 26
Bowl Profiler Tooling & Blades	14
Brake Drum Grinding Wheels	123
Brake Flex-Hones®	124

Brake Lathe

Arbors.....	122
Bits.....	119
Centering Cones.....	123
Cross Feed Shear Gear	122
Cutting Tips	119
Drum Feed Screws & Bushings.....	122, 124
Dust Boots	124
Feed Motor	122
Flexible Arbor Spacers	122
Lead Screw Bushing.....	122, 124
Locking Knob.....	122
Mounting Adaptors	123
Replacement Parts	122 - 124
Rotor Feed Screws.....	122 - 124
Seals.....	122
Serpentine Drive Belts	124
Silencer Bands	121
Spindle Boots	124
Switches	122
Tip Holders	120
Tips.....	119
Wear Inserts, Brass	122
Brake Lubes	123
Brake Shoe Grinding Sleeves	124
Brass Shim Stock	64
Brass Wear Inserts	122
Brazed Carbide Cutting Tools	120
Break-In Lubes	73
Bronze Liners & Tooling	40, 41
Bronze Reaming Oil	33, 39
Bronze-Wall®, Bronze-Wall 2® Bushings	39
Brushes	34, 40, 66, 67, 68, 100, 101, 103
Bucket Lifter Grinder	47
Burets and Stands	49
Burr Buster	118
Burrs, Carbide	62
Bushing Press Kit, Tapered Pin	96

C

Calipers	128, 129
Cam-Shield®	73
Camshaft Work	
Cam Bearing Tools	102, 103
Cam Bore Washing Brushes	66, 103
Cam Wheels	103
Flex-Hones®.....	85, 103
Carbide	
Brake Tips	86, 119
Burrs (Rotary Files)	62
Cutters	3, 10 - 13, 17, 50, 64, 86, 87
Glass Bead Nozzles	70
Pilots	7
Reamers.....	33
Resurfacing Tips.....	50
Rotary Files	62
Sizing Balls	40, 41
Spot Facers / Top Cutters	35
Valve Spring Seat Cutters	48
Cap Grinding Wheels	93
Cartridge Rolls	60, 61

Index

- CBN Cutter Inserts** 50
CBN Dressing Stick 115
CBN Flywheel Stones 115
CC-ing Equipment 49
CC-ing Liquid Concentrate 49
Centering Cones, 60° 40
Ceramlub™ 123
Chamfer Tools 35, 41
Chamfering Cones 48, 91
Chevrolet
Block Organizer Tray 63
Conversion Plate 64
Clamp-On Brake Lathe Silencer 121
Cleaning Supplies
Aprons 71, 138
Baskets 65, 71
Brushes 34, 40, 66 - 68, 100, 101, 103
Cleaning Media 71
De-foaming Agent 69
Detergents 69
Glass Beads 70
Gloves 65, 70, 71
Parts Tumbler Solution 71
Pro-Jet Spray Cleaning Powder 69
Roloc Bristle Discs 67
Safety Gear 61, 62, 65, 71
Scrapers 67, 102
Shop Towels 67
Sludge Filter Bag 74
Soda Blast 70
Ultrasonic Detergents & Filters 69
Clover Lapping Compound 19
Collets
Black & Decker 30
Dowel Puller 113
Expanding Pilots 6
Valve Grinding 27
Compression Release Valves 132
Concentricity Gauges 15, 27
Connecting Rod Heaters 97
Cold Chisel 108
Coolant Filters 75
Coolant Hoses 74
Coolants, Lubricants & Oils
All-Purpose Grinding Coolant 76
Aluminum Machining Aid 61
Belt Resurfacer Coolant 51, 76
Blood Friction Master 73
Brake Lubes 123
Bronze Reaming Oil 33, 39
Cam-Shield® Assembly Lube 73
Crank & Cam Grinding Coolant 76, 103
Cutting and Tapping Fluid 15, 57
Cylinder Honing Oil 76, 88, 90
Diamond Honing Oil 34, 35, 76, 88
Engine Assembly Gel 73
Extreme Pressure Lube 73
First Lube 73
Flywheel Grinding Coolant 76, 112
Flywheel Grinder Table Lubricant 76, 112
Gasket Maker / Thread Sealer 72
Gel Lube 48, 72
Coolants, Lubricants & Oils (cont.)
High Performance Resurfacing Spray 50
High Performance Valve Grinding Aid 29, 76
Honing Oil Concentrate 76
Hylomar® 72
Knurlube 39
Lapping Oil 61, 87
Magnetic Crack Detection Oil 55
Micro Biostat 69
Mineral Based Honing Oil 76, 88
Minnesota Fast Freeze 14, 19, 36
Multi-Duty Grinding Coolant 76
Petroleum Based Rust Prevention 74
Porting & Polishing Machining Aid 61
Plate Lube 54
Press Fit Lubricant 14, 73, 98
Rod Honing Oil 76, 90, 92
Rust Inhibitor for Pressure Tester 58
Rust Proofing Oil 74
Rust Shield 74, 76
Seat Cutting Fluid 16, 76
Spray Assembly Lube 59, 73
Surface Grinding Coolant 52, 76
Titanium Valve Grinding Aid 29, 76
Universal Gel Lube 48, 72
Valve Grinding Oil 29, 76
Valve Seat Machining Aid 15
Way Oil 76
Coolant Magnet 74
Coolant Pumps 74
Core Drills / Reamers 32
Counterbore Cutters 10-13, 17
Crack Detection and Repair
Additives 58
Alumni-Chek 55
Applicators 56
Ceramic Motor Seal 58
Fluid Weld® 58
Goodson Glow 55
Heat Tabs 58
Magnetic Crack Inspection Kit 57
Magnetic Crack Detection Oil 55
Magnetic Field Indicator 56
Magnetic Powder 56
Parker Magnetic Crack Detection Unit 56, 57
Powder 56
Repair Kit 57
Seal-All™ 58
Small Parts Demagnetizer 56
Threaded Plugs, Ironlite® 57
UV Inspection Light 55, 57, 118
Crankshaft
Bearing Scraper 102
Crank Grinding Wheels 4, 104, 105
Crank Welding Plug Rods 110
Dial Indicator, Starrett 106, 129
Diamond Dresser Tools 117
Display Inspection Stand 59, 103
Eliptibur Tool 107
Grinding Coolant 76, 103
Hardness Tester 106
Harmonic Dampener Installer 107
Crankshaft (cont.)
Journal Radius Gauge 106
Peening Tool 108
Plastigage 108
Polishers 109
Polishing Accessories 109
Polishing Belts 110, 111
Polisher Motor 109
Reluctor Ring Installation Tool 107
Steady Rest Shoes 108
Steel Stamps 108
Stroke Checker 108
Stroker Mimic™ 107
Crocus Cloth 61
Cross-Buffs® 60, 61
Cross Feed Dust Boots 124
Cross Feed Shear Gear 123, 124
CSS Ultra Grinding Wheels 4, 105
Cummins Tooling 13, 32, 42
Cutter Drivers & Adaptors 17
Cutting & Tapping Fluid 15, 57
Cylinder Block Work
Automotive Dowel Puller & Collets 113
Bore Washing Brushes 66, 67, 103
Deck Bridge Combination Tool 129
Lifting Sling 102
Oil Gallery Brushes 66, 100
Oil Gallery Plugs & Tools 100
Pin Pal Puller 113
Cylinder Head CC-ing Equipment 49
Cylinder Head Resurfacing
Belt Resurfacer Coolant 51, 76
CBN Cutter Inserts 50
Dressers 53
Grind Aid 109
High Performance Resurfacing Spray 50
PCD Inserts for Aluminum 50
Rotary Broach Tool Bit 50
Segments 52
Surfacing Belts 51
Surfacing Wheels 53
Cylinder Honing
Chamfering Cones and Mandrels 91
Goodson 88 - 90
Honing Oil 76, 88
Keyway Honing Stones 90
Lisle® 91
Nicasil 91
Plateau Honing 90, 94
Portable Cylinder Hones 88
Stones 88 - 94
Sunnen® 88 - 94
D
D-Foam 69
Dampener Installer 107
Deburring Tools 96, 118
Deck Bridge Combination Tool 129
Degree Wheel 102
Demagnetizer 56
Depth Gauge, Flywheel 112
Desmond Style Dressers 53, 112, 118

Index

Detergents 69
Dial Bore Gauge Setting Fixtures 127, 130
Dial Bore Gauges 127, 128
Dial Calipers 129
Dial Indicators 106, 129
Diamond Dresser Tools 31, 93, 116, 117
Diamond Hand Files 11
Diamond Flex-Hones® 85
Diamond Guide Hone Tools 34
Diamond Honing Oil 35, 76, 88
Diamond Laps & Accessories 87
Die Grinding Stones 60, 62
Diesel
Core Drills & Reamers 32
Guide Tooling 32 - 40
Heat Tabs 58
Relief Tooling 13
Seat Installers 19
Spring Compressor 44
Super Abrasive 50
Valve Guide Tooling 32 - 42
Valve Guides 32, 38
Valve Seals 32, 42
Valve Seat Cutter Blades 10 - 13
Dingleberry Hones 36, 85, 91, 103, 124
Disposable Assembly Wipes 67
Distributor Depth Gauge 126
DOHC Organizer Tray 63
DOHC Timing Chain Tensioner 87
Double Angle Valve Seat Wheels 22
Dowel Puller & Collets 113
Dressers
Abrasive Belt Dresser 109
CBN Dressing Stick 115
Cutter Assemblies 53, 112
Desmond-Style Dressers 53, 112, 118
Diamond Stone Dresser 93
Flywheel Stone Dressers 112, 118
Hand-Held Dressing Sticks 106
Premium Diamond Dressers 31, 116, 117
Resurfacer Grinding Wheel Dressers 31
Star Dressers 53, 112
Valve Seat Wheel Dressing Stands 26
Dressing Stand Pilots 6, 26
Drive Adaptors 8, 17
Dykem® Layout Fluid 15

E

Eliptibur Tool 107
Engine Assembly Gel 73
Engine Brush Kit 67
Engine Cart 63
Engine Pre-Lube Supplies 72 - 75
Electric Rod Heater 97
Epoxy, Porting 60
Expanding Pilots 6
Extended Length Pilots (.375" Top) 7
Extended Length Run-Out Gauge 15
Extreme Pressure Lube 73

F

False Guides 38, 136
Fast Freeze 14, 19, 36
Feeler Gauges 125
File, Diamond 11
Filter Bag 74
Filter Inspection Tool 100
Filter Paper & Mats 75
Filters
Hone 75
Ultra-Sonic 69
First Lube 73
Flapwheels 60, 61
Flex-Hones® 34, 85, 91, 103, 124
Fluid Weld® 58
Flywheel Grinding
Bolt Adaptors 112
CBN Flywheel Stones 115
Coolant 76, 112
Dowel Puller & Collets 113
Depth Gauge 112
Dressers 112
Grinding Stones 114, 115
Mounting Adaptors 114
Flywheel Step Gauge 112
FMC
Brake Lathe Replacement Parts 124
Brake Lathe Replacement Tips 119
Ford
Core Drills & Reamers 32
Diesel Seat Cutter Blades 13
Smog Plugs 64
Valve Guides 38
Formula One Boring Tools 87

G

Gas Porting Tools 96
Gasket Maker 72
Gauges
Concentricity Gauge 27
Crankshaft Journal Radius Gauge 106
Distributor Depth Gauge 126
Dial Bore Gauges 127, 128
Feeler Gauges 125
Flywheel Depth Gauge 112
Magnetic Field Gauge 56
Rod Bolt Stretch Gauge 98, 125
Small Hole Gauge Set 41, 125
Split Ball Bore Gauge 41, 125
Spring Tester Height Gauge 42
Sunnen AG-Gauge 126
Telescoping Gauge Set 125
Torque Angle Indicator 59
Vacuum Tester Gauge 54
Valve Seat Height Gauge 26, 128
Valve Seat Run-Out Gauges 15
Valve Stem Height Gauges 48
Warp Gauges 125
Gel Lube 48, 72

General Motors (GM)

Head Bolt Clean-Out Taps 57
Oil Pickup Tube Driver 100
Reluctor Ring Installation Tool 107
Vortec Adaptor Plate Set 64
Glass Beading Supplies 70
Glasses, Safety 61, 62, 108, 113
Gloves
Glass Bead 70
Heat & Flame Resistant 97
Hot Tank Gloves 71
Nitrile 65
Parts Washing Gloves 65
Grind Aid 109
Grinding Stones & Wheels (see Abrasives)
Guide Installers (Drivers) 32, 37
Guide Knurling
Knurling Arbors 39
Knurlube 39
OD Knurling Tool 35
Guide Liners 41
Guide Shoes 90, 92, 93
Guide Tooling, Diesel 32 - 40
Guides 32, 38, 136

H

Hardness Tester 106
Harley-Davidson® (see V-Twin)
Harmonic Dampener Installer 107
Head Bags 65
Head-Bolt Hole Cleaners 57
Head Bolt Spot Facer 64
Head Holders 49, 59
Head Organizer Trays 63
Head Saver Shims, Mercedes 64
Heat Tabs 58
Heavy Metal 113
Height Gauges 26, 48, 128
High Performance
Cam Wheels 103
CC-ing Equipment 49
Gasket Maker & Thread Sealer 72
Resurfacing Spray 50
Valve Grinding Aid 29, 76
Valve Seat Cutter Blades 10 - 13
Valve Spring Booster Shims 49
Valve Spring Compressors 44 - 47, 131
Valve Spring Testers 43
Valve Train Checking Springs 48
High Pressure Cleaning System 68
Hi-Temp Last Blast Paint 72
Honing Oil 76, 88
Honing Stones
Cylinder Honing 88 - 94
Lifter Bore 101
Pin Fitting 93
Rod Honing 92, 93
Valve Guide 34, 36
Hoses 44, 45, 74, 75
Hot Tank Detergents 69
Hylomar® Gasket Maker & Solvent 72

Index

Hyper Finish Diamond Guide Sizing 34, 35

I

ID Tags 63
IDL Valve Refacer Wheels 28
Import Head Stud Stretchers 52
Inspection Lights 55, 57, 118
Inspection Stand 59, 103
Indicators 26, 42, 47, 48, 54, 59, 106, 112, 129
Infinite Flow Cutting Tips (IFT) 10
Intake Port Reshaping Kit 60
Iron-tite 57, 58

J

Jet Spray Cleaning Powder 69
Jet Valve Eliminator Kit 57
Jet Washer Parts Baskets 65

K

Keeper-Keeper 71
Keeper Tools 46, 131
Keyway Honing Stones 90
Knurling 39
Knurlube 39
KO Lee Valve Refacer Wheels 28
Kwik-Way
Belts 31, 51
Boring Bar Cutters 86, 87
Brake Lathe Tips 119
Diamond Lap 87
Drive Adaptor 21, 24
Expanding Pilots 6
Heavy Duty Dressing Stand 26
Rebuild Kit for KW Holders 24
Resurfacers Wheel Segments 52
Single-piece Resurfacers Wheels 53
Solid Tapered Pilots 5, 6
Stone Holders 24
Valve Refacer Replacement Parts 31
Valve Refacer Wheels 28
Valve Seat Grinder Motors 23
Valve Seat Stones 20

L

Lap, Diamond 87
Lapping Compound 19
Lapping Oil 61, 87
Lapping Tools & Compound 18, 19
Last Blast Paint 72
Layout Fluid 15
Letter Stamps 108
Levels & Vials 9, 50
Lifter Bore Tools 101
Lifting Sling 102
Lights
Inspection Lights 55, 57, 118
LED Lights 118
Work Lights 118, 122
Liners, Guide 41
Lint-Free Wipes 67
Lisle® Honing Stone Sets 91

Litmus Paper 69
LS1 Tooling 57
Lubricants
Blood Friction Master® 73
Brake Lubes 123
Cam-Shield® Assembly Lube 73
Extreme Pressure Lube 73
First Lube 73
Flywheel Grinder Table Lubricant 76, 112
Press Fit Lube 14, 73, 98
Spray Assembly Lube 59, 73
Universal Gel Lube 48, 72
Way Oil 76

M

Machine Covers 27, 43, 126
Magnetic Bolt Washer Removers 49
Magnetic Crack Detection 55 - 57
Magnetic Strap Silencer 121
Magnetic Valve Spring Shim Removers 49
Mallory (Heavy Metal) 113
Mandrels
Align Hone 94
Butterfly Mandrels 61
Chamfering Cone Mandrels 48, 91
Cross Buff / Flap Wheel Mandrel 61
Diamond Sizing System 36
Honing 88, 92
Quick Change 60
Roll Mandrels 61
Manual Ring Grinders 99
Manual Spring Compressors 45 - 47
Manual Vacuum Testers 54
Manual Valve Guide Drivers 37
Markers 63, 72
Maxxon Work Lights 55, 57, 118
Measuring Liquid Concentrate 49

Measuring Tools

Bore Gauges 127, 128
Calipers 129
Crankshaft Dial Indicator 106, 129
Dial Indicators 106, 129
Distributor Depth Gauge 126
Feeler Gauges 125
Flywheel Depth Gauge 112
Micrometers 130
Rod Bolt Stretch Gauges 98, 125
Small Hole Gauge Set 41, 125
Straight Edges 125
Stroke Checker 108
Telescoping Gauge Set 125
Valve Seat Height Gauge 26, 128
Valve Seat Run-Out Gauge 15
Valve Stem Concentricity Gauge 27
Valve Stem Height Gauges 48
Warp Alignment Gauge 125

Metal Markers

Micrometers 130
Micro Ball Head Tooling 9
Micro Biostat 69
Micro Valve Seat Stones 20, 22
Milwaukee-Eight™ Parts 132 - 137

Milwaukee-Eight™ Head Plate 131
Minnesota Fast Freeze 14, 19, 36
Mitutoyo®
Dial Bore Gauge 128
Hole Gauge Set 41, 125
Split Ball Bore Gauge 41, 125
Mondello Seat Cutter Blades 10
Motors
Brake Lathe 122
Crankshaft Polisher 109
Seat Grinding 21, 23, 25
Mounted Points 60, 62
Mr. Race Oil Engine Assembly Gel 73

N

Neway

Easy Turn Wrench 16
Pilots 5 - 7
Replacement Cutter Blades & Screws 16
Valve Seat Cutters 16
Nicasil Honing Stones 91
Number Stamps 108

O

O-Ring Wire 87
OHC Bucket Grinder 47
Oil Filter Tools 100
Oil Gallery Brushes 66, 100
Oil Gallery Cleaning System 68
Oil Gallery Tools 100
Oil Gallery Wax 100
Oil Pre-lube Tank 75
Oil Pump Belts 92
Oil Pump Tools 100
On-The-Engine Spring Compressor ... 47, 131
Organizers 63
Oversize Bronze-Liners 41
Oversize Valve Guides 38, 136
Oversize Valve Seat Inserts 18, 135

P

Paint

Last Blast Spray Paint 72
Markers 72
Paper Shop Towels 67

Parts Cleaning

Airless Blaster Media 71
Baskets 65, 71
Brushes 34, 40, 66 - 68, 100, 101, 103
Detergent Powders 69
Glass Bead Tools & Supplies 70
Gloves 65, 70, 71, 97
Keeper-Keeper 71
Parts Tumbler Solution 71
Pro-Jet Spray Cleaning Powder 69
Roloc Bristle Discs 67
Soda Blast Media 70
Super Scraper™ 67
Surface Conditioning Discs 61
Tumbler Cleaning Media 71
Ultrasonic Detergents & Filters 69

- Parts Storage & Organizers**
- Valve Stem Protectors 71
 - Baskets 65
 - DOHC Cylinder Head Tray 63
 - Engine Cart 63
 - Keeper-Keeper 71
 - Organizer Trays 63
- Parts Storage & Organizers (cont.)**
- Parts Tags & Marker 63
 - Plastic Bags 65
 - Safety Pins 63
 - Shrink Wrap 65
- Parts Tumbler Media** 71
- Pastelub™ Hi-Temp Brake Lube** 123
- Peening Tool** 108
- Performance Brake Lathe Tips** 119
- Peterson**
- Boring Bar Cutters 86
 - Core Drills & Reamers 32
 - Crankshaft Grinding Wheels 104 - 105
 - Cylinder Head Resurfacing Belts 51
 - Resurfacer Abrasives 51 - 53
- pH Test Strips** 69
- Pilots**
- Expanding 6
 - Extended Length Top Solid-Tapered 7
 - Micro 5 - 7
 - Seat Dresser 6, 7, 26
 - Solid-Tapered Steel 5
 - Specialty 38, 48
 - Tapered Carbide 7
- Pin Bushing Press Kit** 96
- Piston Installing Tools**
- Deadblow Hammer 98
 - Electric Rod Heater 97
 - Gas-Fired Rod Heater 97
 - Piston Pin Installing Fixture 95
 - Ring Compressing Pliers 97
 - Rod Clamping Vise 98
- Piston Pin Removal Fixture** 95
- Piston Ring Filers** 99
- Plastigage** 108
- Plateau Honers** 39, 90, 94
- Plugs**
- Crack Repair 57
 - Oil Gallery 100
 - Smog Plugs 64
- Pneumatic Tools**
- Air Hammer 37
 - Lapping Tool 19
 - Valve Guide Drivers 37
 - Valve Spring Compressors 44, 45
- Polishing Belts** 110, 111
- Polishing Rouge** 109
- Portable Cylinder Honers** 88
- Porting & Polishing**
- Abrasives Kits 60
 - Aluminum Oxide Cloth Shop Rolls 61
 - Butterfly Mandrels 61
 - Crocus Cloth 61
 - Cross-Buffs® 60, 61
 - Epoxy 60
- Porting & Polishing (cont.)**
- Flapwheels 60, 61
 - Mandrels 60, 61
 - Mounted Wheels 62
 - Port Reshaping Kit 60
 - Porting Kits 60
 - Porting & Polishing Machining Aid 61
 - Replacement Abrasives and Mandrels 61
 - Rotary Files 62
- Powered Ring Filer** 99
- Pre-Lube Tank** 75
- Premium Tapered Reamers** 118
- Pre-Oiler** 75
- Press Fit Lubricant** 14, 73, 98
- Press Kit, Tapered Pin** 96
- Pressure Lube** 73
- Pressure Tester Rust Inhibitor** 58
- Pro Jet Spray Cleaning Powder** 69
- Prussian Blue** 15
- Pullers** 18, 42, 59, 113
- Pumps** 35, 74
- R**
- Radiac Abrasives**
- Blanchard Grinder Wheels 53
 - Cam Grinding Wheels 103
 - CBN Cutters 50
 - CBN Flywheel Grinding Wheels 115
 - Crankshaft Grinding Wheels 4, 104, 105
 - Flywheel Grinding Wheels 115
 - PCD Cutters 50
 - Resurfacing Segments 52
 - Resurfacing Wheels 53
 - Valve Refacing Wheels 28, 29
- Radial Wire Brushes** 67
- Reamers**
- Bronze 33
 - Carbide Valve Guide 33
 - Core 32
 - Diesel 32
 - High Speed Steel for Cast Iron 33
 - Piloted Core Reamers 32
 - Small Diameter 33
 - Tapered 118
- Reaming Oil** 33, 39
- Rebuilding Kits**
- Stone Holder 24
- Reluctor Ring Installation Tool** 107
- Reluctor Rings** 107
- Removers**
- Booster Shim 49
 - Bronze Liners 41
 - Cam Bearings 102
 - Dowel Pin Pullers 113
 - Keeper 46
 - Liner Removal Tool Driver 41
 - Oil Gallery Plugs 100
 - Piston Pin 95
 - Piston Rings 97, 98
 - Stud 59
 - Tapered Pin Bushings 96
- Removers (cont.)**
- Valve Guide 37
 - Valve Seat 9, 18
 - Valve Seat Stone 21, 23 - 26
 - Valve Stem Seal 42
 - Washer 49
- Resurfacing Belts** 51
- Resurfacing Coolant** 51, 52, 76
- Resurfacing Dressers** 53
- Resurfacing Spray** 50
- Resurfacing Wheel Segments** 52
- Resurfacing Wheels** 53
- Right Angle Air Driver** 25
- Ring Band Compressors** 97
- Ring Expanders** 98
- Ring Grinders** 99
- Rocker Arm Tools** 59
- Rockwell Hardness Tester** 106
- Rod and Cap Grinding Wheels** 93
- Rod Balancing Supplies** 113
- Rod Bolt Boots** 98
- Rod Bolt Installing Block** 98
- Rod Bolt Stretch Gauge** 98, 125
- Rod Clamping Vise** 98
- Rod Heaters** 97
- Rod Hone Filter Mat** 75
- Rod Honing** 92, 93
- Rod Honing Oil** 76, 90, 92
- Roloc Bristle Discs** 67
- Rotary Broach Tool Bits** 50, 112
- Rotary Files** 62
- Rotor Adaptors** 123
- Rotor Silencers** 121
- Rottler**
- Boring Bar Cutters 86
 - Diamond Lap 87
 - Sleeve Cutters 86
 - Valve Refacer Wheels 28
- Round Brake Lathe Tips** 119
- RTI Brake Lathe Tips** 119
- Rubber Abrasive Belt Dresser** 109
- Rust Protection** 74, 76
- S**
- Saber Tooth Seat Cutter Blades** 3, 10 - 13
- Safety Glasses** 61, 62, 108, 113
- Safety Pins** 63
- Scales, Balancing** 113
- Scrapers** 67, 102
- Screws**
- Ball Head 8, 9
 - Boring Bar 86
 - Carbide Cutter 8, 9, 14, 17
 - Catspaw 86
 - Cross Buff Mandrel 61
 - Feed Screws 122 - 124
 - Neway 16
- Scribe Tools** 15
- Seal-All™** 58
- Seals** 32, 42, 135
- Seal Cutters** 38, 48, 131

Index

Seal Pullers.....	42
Seal Setters.....	135
Seats.....	18, 135
Seat Cutters.....	8 - 14, 16 - 17, 48
Seat Cutting Fluid.....	16
Seat Drivers.....	19
Seat Grinding (see Valve Seat Grinding)	
Seat Removers.....	9, 18
Segments.....	52
Serdi-Style Bodies & Drivers.....	8
Shim Remover.....	49
Shim Stock.....	64
Shims.....	49, 64
Shot	
Ceramic & Steel.....	71
Glass.....	70
Shop Towels, Lint-Free.....	67
Shrink Wrap.....	65
Silencer Bands, Brake Lathe.....	121
Silencer Brake Spray.....	123
Sioux™ Replacement Parts	
Belts.....	30
Driver Parts.....	21, 23, 24, 30
Parts Tumbler Rebuild Parts.....	71
Vacuum Tester Gauge.....	30
Valve Grinder Parts.....	30
Valve Refacer Parts.....	30
Wheel Dresser Parts.....	30
Sioux-Style	
Drive Adaptor.....	23
Drivers.....	23
Pilots.....	5 - 7
Stone Holders.....	24
Vacuum Plates.....	30
Valve Refacer Wheels.....	29
Valve Seat Grinding Kit.....	23
Valve Seat Stone Removers.....	23, 24
Valve Seat Wheels.....	22, 23, 25
Sizing Balls.....	40, 41
Sling, Lifting.....	102
Sludge Filter Bag (Sock).....	74
Smog Plugs.....	64
Snap-on	
Replacement Brake Lathe Cutting Tips... 119	
Valve Refacer Wheels.....	29
Spark Plug Thread Chaser/Burnisher.....	118
Spindle Boots.....	124
Split Ball Bore Gauge.....	41, 125
Spot Facers.....	64
Spray Assembly Lube.....	59, 73
Spray Bluing Fluid.....	15
Spring Compressors.....	44 - 47, 131
Spring Pad Cutters.....	14, 48
Spring Testers.....	43
Stamps, Steel.....	108
Steady Rest Shoes.....	31, 108
Steel Shim Stock.....	64
Step Gauge.....	112
Stone Holders.....	21, 23 - 25

Stones	
Camshaft.....	103
Crankwheel.....	104, 105
Flywheel.....	114, 115
Honing.....	88 - 94
Porting & Polishing.....	60, 63
Refacing.....	28, 29
Resurfacing.....	52, 53
Rod Honing.....	92, 93
Valve Seat.....	20 - 25
Storage Bags.....	65
Storage Cart.....	63
Storm-Vulcan	
Crankshaft Grinding Wheels.....	105
Resurfacer Belts.....	51
Resurfacer Wheel Segments.....	52
Resurfacing Carbide Cutter Tips.....	50
Straight Edges.....	125
Stroke Checker.....	108
Stroker Mimic™.....	107
Stud Extractor.....	59
Stud Stretchers.....	52
Sunnen®	
AG-Series Precision Gauge.....	126
Align Hone Mandrels.....	94
Belts for Rod Honing Machines.....	92
Cap Grinding Wheels.....	93
Coolants.....	76
Core Drills & Reamers.....	32
CV-616 Honing Machine Parts.....	92
Cylinder Honing Stones.....	88 - 94
Dial Bore Gauges.....	127
Guide Shoes.....	90, 92, 93
Lifter Bore Hones.....	101
Main Bore Align Hone Mandrels.....	94
Mandrel Drivers.....	92, 94
Master Holder & Stone Supports.....	88
Oil Pump Belts.....	92
Plateau Honing Tools, Ultra-Finish.....	90
Portable Cylinder Hones.....	88
Press-Fit Lubricant.....	14, 73, 98
Replacement Parts for CV-616.....	92
Rod Honing Machine Belts.....	92
Rod Honing Stones & Guide Shoes .. 92, 93	
Silicon Compound (AN-30).....	94
Truing Sleeves.....	36, 101
Valve Guide Gauge Set.....	126
Valve Guide Hone Set.....	36
Valve Refacer Steady Rest Shoes.....	31
Valve Refacer Wheels.....	28, 29
Super Scraper™.....	67
Surfacing	
Belts.....	51
CBN Inserts.....	50
Coolants.....	51, 52, 76
PCD Inserts.....	50
Segments.....	52
Wheels.....	53
Swedge Cutting Tool.....	124
Switches.....	21, 23, 25, 30, 122

T

Tap, Clean-Out.....	57
Tapered Pin Bushing Kit.....	96
Tapered Reamers.....	118
Tapping Fluid.....	15, 57
Taps	
Crack Repair.....	57
Head Bolt.....	57
Telescoping Gauge Set.....	125
Temperature Indicator Crayons.....	97
Tensioner Stop Block.....	87
Thin Wall Bronze Liners.....	41
Thread Chaser.....	118
Timing Chain Tensioner.....	87
Tip Holders, Brake Lathe.....	120
Titanium Coated Cutting Tips.....	119
Tooling Stands.....	48
Top Cutters.....	35, 64
Torque-Angle Indicator.....	59
Trays, Organizing.....	63
Tumbling Media.....	71

U

Ultra-Finish Plateau Honing Tools .. 39, 90, 94	
Ultrasonic Detergents & Filters.....	69
Universal Checking Standards.....	130
Universal Dressing Stand.....	26
Universal Gel Lube.....	48, 72
Universal Head Holder.....	49, 59
Universal Spring Pad Cutter.....	14
Utility Rolls.....	61
UV Inspection Light.....	55, 57, 118

V

V-Twin

Compression Release Valves.....	132
Hard Parts.....	132 - 137
On-the-Engine Spring Compressor ... 47, 131	
Valve Guides.....	136
Valve Seals.....	135
Valve Seat Inserts.....	18, 135
Valve Spring Compressors.....	47, 131
Valve Springs.....	132 - 134
Valves.....	134 - 137
Vacuum Plates.....	30, 54
Vacuum Testers.....	54
Valve Grinding	
Adaptor for ½" Chucks.....	27
Black & Decker Valve Refacer Collets.....	30
Diamond Dresser Tools.....	31, 117
Dresser Pilots.....	6, 7, 26
Machine Covers.....	27
Machine Parts.....	30, 31
Valve Grinding Aid.....	29, 76
Valve Grinding Oil.....	29, 76
Valve Refacer Wheels.....	28, 29
Valve Stem Concentricity Gauge.....	27

Valve Guide		Valve Seat (cont.)		Valve Spring Shim Remover	49
Bronze-Liners	40, 41	Cutting Fluid	16	Valve Spring Testers	43
Bronze-Wall® & Bronze-Wall 2®	39	Cutting System	8, 9, 16, 17	Valve Stem	
Brushes	34, 40, 66	Dressers	21, 23, 25, 26	Concentricity Gauge	27
Core Drill / Reamer	32	Drivers	21, 23, 25	Dial Indicated Valve Stem Height Gauge ...	48
Diamond Hone Set	34	Inserts	18, 135	Protectors	71
Drivers	32, 37	Layout Fluids	15	Valve Stem Oil Seals	32, 42, 135
Flex-Hones®	36, 85	Machining Aid	15	Valves	134, 137
Gauge Sets	41, 125, 126	Minnesota Fast Freeze	14, 19, 36	Van Norman	
Guides	38, 136	Neway Seat Cutting System	16	Boring Bar Cutters & Parts	86, 87
Hone Set	34, 36	Nickel-Chrome Valve Seats	18	Core Drills & Reamers	32
Knurling Tools	39	Removers	9, 18	Crankshaft Grinding Wheels	105
OD Chamfer Tool	35	Run-Out Gauges	15	Flywheel Cutter	112
OD Knurling Tool	39	Stone Holders	24	Resurfacer Segments	52
Plateau Hones	39	Valve & Seat Scribe	15	Single-piece Resurfacer Wheels	53
Reamers	33	Valve Seat Cutter Blades	3, 10 - 13, 16	Valve Refacer Wheels	29
Small Hole Gauge Set	41, 125	Valve Seat Counterbore Cutters	17	Vials, Level	9, 50
Spot Facer	64	Valve Seat Grinding	20 - 26	Vortec Tools	64
Top Collars	35	Valve Seat Insert Driver	19		
Top Cutters	35, 64	Valve Seat Wheels	20 - 25	W	
Valve Guide Brushes	34, 40, 66	Valve Spring		Warp Gauge	125
Valve Guides	38, 136	Adaptors	45, 46	Water Based Honing Coolant	88
Valve Lapping Tools & Supplies	18, 19	Booster Shims	49	Way Oil	76
Valve Refacing Wheels	28, 29	Calibrated Springs	42	Wear Inserts, Ammco	122
Valve Seal Drivers	135	Compressors	44 - 47, 131	Wear Sleeves	17
Valve Seal Pullers	42	Height Indicator	42	Welding Rods	110
Valve Seal Setter	135	Inserts	49	Wipes	67
Valve Seals	32, 42, 135	Keeper Installation Tools	46, 131	Wire Wheels & Brushes	66, 67
Valve Seat		Manual Valve Spring Bench	45	Wrist Pin Bushing Press Kit	96
Aviation Seat Grinding Kit	25	Pneumatic Valve Spring Press	44		
Basic Valve Seat Grinding Kits	21, 23	Seat Cutters	48		
Bounce Springs	8, 9, 24, 26	Spring & Retainer Kits	132 - 134		
Cutter Blades	3, 10 - 13, 17	Testers	43		
Cutter Drivers	8, 9, 16, 17	Valve Spring Inserts	49		

California Proposition 65



WARNING: Cancer and Reproductive Harm - www.P65Warnings.ca.gov

"Proposition 65 requires businesses to provide warnings to Californians about significant exposures to chemicals that cause cancer, birth defects or other reproductive harm."

Due to recent regulatory changes in California, we must now warn you that many of the materials commonly used to manufacture our products contain chemicals known to the state of California to cause cancer and reproductive harm.

A complete list of materials requiring the Prop 65 warning can be found at <https://www.p65warnings.ca.gov>.

WARNING: Operating, servicing and maintaining a passenger vehicle or off-road vehicle can expose you to chemicals including engine exhaust, carbon monoxide, phthalates, and lead, which are known to the State of California to cause cancer and birth defects or other reproductive harm. To minimize exposure, avoid breathing exhaust, do not idle the engine except as necessary, service your vehicle in a well-ventilated area and wear gloves or wash your hands frequently when servicing your vehicle. For more information go to www.P65Warnings.ca.gov/products/passenger-vehicle.

If you need additional information about any specific products sold by Goodson, please check our website or contact the Goodson Techxperts for details. Call 1-800-533-8010.

Your Shortcuts

Use the space below to record your most frequently ordered items.

Policies

Pricing:

Prices are subject to change without notice. There is no minimum order. Orders are billed at the prices in effect at the time of shipping. Discounts are not available on Sunnen® products.

Shipping:

Goodson makes every effort to ship orders the same day they are received. Due to carrier cut-off times, orders received after 2:00 pm (central time), on weekends or holidays may not ship until the next business day.

You have several choices of shipping methods. Cost of shipping is based on total weight or package dimensions and the distance from our warehouse. **Goodson is not responsible for weather related shipping delays.**

- **STANDARD:** Unless otherwise requested, we ship items up to 100 pounds and up to 130" in combined width, length and height by US Postal Service, UPS or FedEx services. Items over the weight or size limit must go by common carrier.
- **EXPRESS:** We can ship most items by air to arrive in your choice of 1, 2 or 3 days. Aerosol products, however, require a HazMat fee when shipped by air.

Upon receipt of your order, please inspect all cartons immediately for damaged or missing products BEFORE signing for the merchandise. Any packages received in a damaged condition should be rejected and/or noted at the time of delivery. If items are missing or damaged, please contact Goodson within 3 business days.

Freight Allowance:

For open account orders shipped ground within the USA, you may deduct the freight charges on any **JOBBER** net invoice of **\$800** or more if you pay within 30 days (including Internet orders). However, Glass Beads, Steel Shot, Tumbler Media, Machines, Equipment, Bulk Liquids, Cleaning Detergents and Crankwheels are not included (shipped F.O.B. Winona, MN). Hazardous Materials, Dangerous Goods and Dimensional Shipping fees may apply on certain items. Please call to inquire.

Terms:

- 1) A 1% discount is given on merchandise if payment is made within 15 days from invoice date. This discount applies to the merchandise amount only (not the total amount) on the invoice (not a statement). The discount amount is shown in the lower left hand corner of the invoice. This discount does not apply to statement payments and does not apply to credit card or PayPal orders.
- 2) Balances not paid in full within 30 days are subject to a finance charge of 1.5% per month (18% per year).

Credit & Debit Card Orders:

Goodson accepts MasterCard, Visa, American Express, Discover Card and PayPal. For your security, credit card numbers are NOT kept on file. Credit card and PayPal orders do not qualify for the 1% quick-pay discount.

Check Acceptance:

In the unlikely event that your check is returned for insufficient or held funds, we will debit your checking account electronically for the face amount of the check plus the service fee allowed by your state's law. This allows us to resolve the problem without turning you over to a collection agency and harming your credit rating. The transaction will appear on your bank statement and no one will have to contact you about payment.

Returns:

You may return any item, **except special orders and HazMat* items**, within 60 days. We will do our best to correct any problems or to send a replacement. If an item was damaged through mis-use or modification, Goodson will not accept it as a return. Credits will only be issued after it is determined that the part is resellable or it is deemed defective.

To return an item, please follow these easy steps:

1. Enclose a note explaining why you're returning the product. For faster processing, be sure to include your name and account number (you'll find this on your invoice)
2. Ship the item freight prepaid within 60 days from invoice date to
Goodson Tools & Supplies for Engine Builders
ATTN: Returns
156 Galewski Drive
Winona, MN 55987

For best results, please ship return merchandise by a trackable shipping method. Keep your shipping receipt as it may be necessary to track the package if it is lost in transit. A 10% restocking fee may apply on returns unless the problem was the fault of Goodson. If so, the restocking fee is waived and shipping costs are reimbursed.

ABRASIVES WARRANTY: Abrasives have a shelf-life, therefore, all abrasives are warranted against manufacturing defects for 1 year from the date of original purchase.

***HAZMAT ITEMS:** Only businesses certified to ship Hazardous Goods can ship such items. To return a HazMat item to Goodson, please call us at **1-800-533-8010** for shipping recommendations.

Privacy Policy:

All information that Goodson collects from its customers through purchases, credit applications or other transactions is kept private and is not disclosed to anyone except as permitted or required by law. Goodson will not sell or trade this information to anyone. Goodson will limit employee access to customers' private information to only those employees who need to know the information to provide products and services to you. Goodson maintains internal safeguards to protect our customer's non-public information. Please visit our website to read our privacy policy at <https://goodson.com/pages/privacy-policy> or scan the code at right to be directed to the page.



International Sales:

All items shipped F.O.B. Winona, MN, USA. To find a distributor near you, visit www.goodson.com.

Goodson currently has stocking distributors in:

- Austria • Australia • Belgium
- Canada • Chile • Colombia
- Costa Rica • Ecuador
- El Salvador • Finland
- France • Germany
- Guatemala • Honduras • Ireland • Italy • Mexico • Netherlands
- New Zealand • Norway • Poland • Spain • Suriname • Sweden
- Switzerland • Taiwan • Turkey • United Kingdom



Resharpener & Resetting:

Goodson offers Resetting & Resharpener services for the following:

- Diamond Dressers • CBN & PCD Resurfacing Cutters
 - Valve Seat Cutter Blades • Rotary Broach Tool Bits for Van Norman
- Get more information and pricing by calling **1-800-533-8010**.

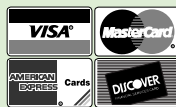

Flex-Hones® For Any Type And Size Of Cylinder

- Abrasive globules each have independent suspension • Self-centering • Self-aligning • Self-compensating for wear
- Applications are interchangeable, select bore size • Right Hand rotation only

CYLINDER HEAD REBUILDING
CLEANING, ASSEMBLY & SAFETY
SHORT BLOCK REBUILDING
GRANKSHAFT/FLYWHEEL GRINDING
MISCELLANEOUS TOOLS & SUPPLIES
BRAKE SERVICE TOOLING
MEASURING
V-TWIN & METRIC HARD PARTS

240 Grit Silicon-Carbide Valve Guide Flex-Hones®

- Ideal for all materials including cast iron, bronze, phosphor bronze and aluminum

Size mm	OAL	Jobber	Order No.	Incl.
6 Pc. Kit \$91.99 VG-F-KIT ▼				
1 ¹ / ₆₄ "	4.5	6"	23.99	VG-F-4.5MM
1 ³ / ₆₄ "	5.0	8"	23.99	VG-F-5MM
7 ¹ / ₃₂ "	5.5	8"	23.99	VG-F-5.5MM
1 ¹ / ₄ "	6.4	8"	23.99	VG-F-6.4MM x
9 ¹ / ₃₂ "	7.0	8"	23.99	VG-F-7MM x
5 ¹ / ₁₆ "	8.0	8"	23.99	VG-F-8MM x
11 ¹ / ₃₂ "	9.0	8"	23.99	VG-F-9MM x
3 ¹ / ₈ "	10.0	8"	23.99	VG-F-10MM x
7 ¹ / ₁₆ "	11.0	8"	23.99	VG-F-11MM x
15 ¹ / ₃₂ "	12.0	8"	23.99	VG-F-12MM
33 ¹ / ₆₄ "	13.0	8"	23.99	VG-F-13MM
7 ¹ / ₁₆ "	14.0	8"	23.99	VG-F-14MM
19 ¹ / ₃₂ "	15.0	8"	23.99	VG-F-15MM

400 Grit Diamond Valve Guide Flex-Hones®

- Ideal for heat treated steel, high nickel stainless steel, chromes or plated bores, MMX aluminum alloys, ceramics and carbide

Size mm	OAL	Jobber	Order No.
1 ¹ / ₄ "	6.4	8"	\$42.99 VGFD-6.4MM
7 ¹ / ₃₂ "	7.0	8"	42.99 VGFD-7MM
5 ¹ / ₁₆ "	8.0	8"	42.99 VGFD-8MM
11 ¹ / ₃₂ "	9.0	8"	42.99 VGFD-9MM
3 ¹ / ₈ "	10.0	8"	42.99 VGFD-10MM



Order 3 or more Flex-Hones® (mix & match) and save 10% off jobber

120 Grit Silicon-Carbide Flex-Hones®

- Ideal for all materials including cast iron, bronze, phosphor bronze and aluminum
- When ordering heavy-duty, order on cylinder size

Size	Standard			Heavy-Duty			
	mm	OAL	Jobber	Order No.	OAL	Jobber	Order No.
2"	50.8	8"	\$29.99	BG-210	—	—	—
2 ¹ / ₄ "	57.2	8"	32.99	BG-225	—	—	—
2 ¹ / ₂ "	63.5	8"	34.99	BG-250	—	—	—
2 ³ / ₄ "	69.8	8"	37.99	BG-275	—	—	—
3"	76.2	8"	43.99	BG-300	13 ¹ / ₂ "	\$70.99	BGD-300
3 ¹ / ₄ "	82.6	13 ¹ / ₂ "	48.99	BG-325	13 ¹ / ₂ "	75.99	BGD-325
3 ¹ / ₂ "	88.9	13 ¹ / ₂ "	53.99	BG-350	13 ¹ / ₂ "	77.99	BGD-350
3 ³ / ₄ "	95.3	13 ¹ / ₂ "	59.99	BG-375	13 ¹ / ₂ "	80.99	BGD-375
4"	101.6	—	—	—	13 ¹ / ₂ "	89.99	BGD-400
4 ¹ / ₈ "	104.8	13 ¹ / ₂ "	59.99	BG-418	—	—	—
4 ¹ / ₄ "	107.9	—	—	—	13 ¹ / ₂ "	95.99	BGD-425
4 ³ / ₈ "	111.1	13 ¹ / ₂ "	79.99	BG-438	—	—	—
4 ¹ / ₂ "	114.3	—	—	—	13 ¹ / ₂ "	97.99	BGD-450
4 ⁵ / ₈ "	117.5	13 ¹ / ₂ "	70.99	BG-462	—	—	—
5 ¹ / ₂ "	139.7	—	—	—	17 ¹ / ₂ "	128.99	BGD-550
6"	152.4	—	—	—	17 ¹ / ₂ "	129.99	BGD-600
6 ¹ / ₂ "	165.1	—	—	—	17 ¹ / ₂ "	149.99	BGD-650

180 Grit Silicon-Carbide Flex-Hones®

- Ideal for all materials including cast iron, bronze, phosphor bronze and aluminum
- Sizes with extra-long shanks are ideal for cam bearings

Size	Standard			Extra-Long Shank*			
	mm	OAL	Jobber	Order No.	OAL	Jobber	Order No.
5 ¹ / ₈ "	15.9	8"	\$19.99	BH-625	—	—	—
3 ¹ / ₄ "	19.1	8"	20.99	BH-750	—	—	—
13 ¹ / ₁₆ "	20.6	8"	24.99	BH-820	—	—	—
7 ¹ / ₈ "	22.2	8"	20.99	BH-875	—	—	—
1"	25.4	8"	21.99	BH-1000	—	—	—
1 ¹ / ₈ "	28.6	8"	22.99	BH-1125	—	—	—
1 ¹ / ₄ "	31.8	8"	24.99	BH-1250	—	—	—
1 ³ / ₈ "	34.9	8"	25.99	BH-1375	—	—	—
1 ¹ / ₂ "	38.1	8"	26.99	BH-1500	—	—	—
1 ⁵ / ₈ "	41.3	8"	26.99	BH-1625	—	—	—
1 ³ / ₄ "	44.5	8"	28.99	BH-1750	17 ¹ / ₂ "	\$57.99	CBF-175*
2"	50.8	8"	29.99	BH-2000	17 ¹ / ₂ "	59.99	CBF-200*
2 ¹ / ₄ "	57.2	8"	32.99	BH-2250	17 ¹ / ₂ "	60.99	CBF-225*
2 ¹ / ₂ "	63.5	8"	34.99	BH-2500	17 ¹ / ₂ "	62.99	CBF-250*
2 ³ / ₄ "	69.8	8"	35.99	BH-2750	17 ¹ / ₂ "	63.99	CBF-275*

*CBF flex-hones include an extender & nipple for OAL of 17¹/₂"

320 Grit Standard Duty Silicon-Carbide Flex-Hones®

- Ideal for all materials

Size	mm	OAL	Jobber	Order No.
1 ¹ / ₄ "	31.8	8"	\$39.99	BG-125320
2 ¹ / ₄ "	57.2	8"	47.99	BG-225320
3"	76.2	8"	64.99	BG-300320
3 ¹ / ₄ "	82.6	13 ¹ / ₂ "	75.99	BG-325320
3 ¹ / ₂ "	88.9	13 ¹ / ₂ "	80.99	BG-350320
3 ³ / ₄ "	95.3	13 ¹ / ₂ "	86.99	BG-375320
4 ¹ / ₈ "	104.8	13 ¹ / ₂ "	89.99	BG-418320
4 ³ / ₈ "	111.1	13 ¹ / ₂ "	118.99	BG-438320
4 ⁵ / ₈ "	117.5	13 ¹ / ₂ "	107.99	BG-462320

320 Grit Heavy Duty Silicon-Carbide Flex-Hones®

- Ideal for all materials

Size	mm	OAL	Jobber	Order No.
4"	101.6	13 ¹ / ₂ "	\$129.99	BGD-400320
4 ¹ / ₄ "	107.9	13 ¹ / ₂ "	140.99	BGD-425320
4 ¹ / ₂ "	114.3	13 ¹ / ₂ "	145.99	BGD-450320

240 Grit Aluminum-Oxide Flex-Hones®

- Ideal for hard surfaces such as Nicasil and hardened steel

Size	mm	OAL	Jobber	Order No.
2 ¹ / ₄ "	57.2	8"	\$41.99	BA-225240
2 ³ / ₈ "	60.2	8"	43.99	BA-237240
2 ¹ / ₂ "	63.5	8"	44.99	BA-250240
2 ⁵ / ₈ "	66.8	8"	46.99	BA-262240
2 ³ / ₄ "	69.8	8"	48.99	BA-275240
3"	76.2	8"	56.99	BA-300240
3 ¹ / ₄ "	82.6	13 ¹ / ₂ "	63.99	BA-325240
3 ¹ / ₂ "	88.9	13 ¹ / ₂ "	68.99	BA-350240
3 ³ / ₄ "	95.3	13 ¹ / ₂ "	73.99	BA-375240
4 ¹ / ₈ "	104.8	13 ¹ / ₂ "	77.99	BA-418240
4 ⁵ / ₈ "	117.5	13 ¹ / ₂ "	86.99	BA-462240

RIGHT HAND ROTATION ONLY! For best results, always use with an ample flow of honing oil

... another satisfied customer

"Top quality at reasonable prices. Never settle for anything less than Goodson Tools and Supplies."

- Mike, Tampa, FL, Goodson customer since 2020

CYLINDER HEAD REBUILDING

CLEANING, ASSEMBLY & SAFETY

SHORT BLOCK REBUILDING

CRANKSHAFT/ FLYWHEEL GRINDING

MISCELLANEOUS TOOLS & SUPPLIES

BRAKE SERVICE TOOLING

MEASURING TOOLS

V-TWIN & METRIC HARD PARTS



WINONA VAN NORMAN, VAN NORMAN, PETERSON, KANSAS INSTRUMENTS

1-EDGE CUTTER BIT

Fits Model Numbers	Type	Bit Dia.	Jobber	Order No.
777, 900, 905, 944, 965	General	1/4"	\$46.99	VN-1
777S, 777S4, 944S, CB11, BC22XL, PK447S	General	3/8"	46.99	VGS-1
	Hard Sleeves	3/8"	46.99	VGS-2
	Sleeve Cutter	3/8"	46.99	VGS-3
888, 999	General	1/4"	68.99	VN-360

Original Van Norman

Fits Model Numbers	Type	Bit Dia.	Jobber	Order No.
777S, 944S	Hard Sleeves	3/8"	\$56.99	777-179

HOLDERS FOR 6-EDGE TIPS - Use RT-6B and RT-6BT (each holder includes one tip)

Fits Model Numbers	Length	Height	Jobber	Order No.
777, 900, 905, 944, 965	1 7/8"	3/4"	\$196.99	VN-135
777S, 777S4, 944S	2"	1 3/16"	197.99	VN-122

Bore Range: 2.65" to 4.50"

Standard Carbide Replacement Cutter Tip		\$11.99	RT-6B
Titanium Coated Carbide Replacement Tip		12.99	RT-6BT enlarged

MISCELLANEOUS PARTS

Fits 6-Edge Holders Above	Bit Screw	\$4.79	VN-130
---------------------------	-----------	--------	--------

tech tips
from the techexperts™

VN-130 will also fit KWL-116



KWIK-WAY

1-EDGE CUTTER BIT FOR OE HOLDERS

Fits Model Numbers	Type	Bit Dia.	Jobber	Order No.
F, FT, FL, FN, FR, FS,	Rough	5/16"	\$34.99	KWL-R
FW, FWS, FWSII, FX	Finish	5/16"	34.99	KWL-F
Models After 1770	Sleeve Cutter	5/16"	34.99	KWL-C

HOLDER FOR 6-EDGE TIPS - Uses RT-6B or RT-6BT Tips (each holder includes one tip)

Fits Model Numbers	Length	Height	Jobber	Order No.
FL, FN, FR, FS, FT, FW	2 1/16"	5/8"	\$167.99	KWL-116

Standard Carbide Replacement Cutter Tip		11.99	RT-6B
Titanium Coated Carbide Replacement Cutter Tip		12.99	RT-6BT

PETERSON-BERCO

1-EDGE CUTTER BIT FOR OE HOLDERS

Fits Model Numbers	Length	Bit Dia.	Jobber	Order No.
ACP-151-A, ACP-151-BL, SCP-151-P	1 3/4"	10mm	\$39.99	PB-151

ROTTLER

1-EDGE CUTTER BIT FOR OE HOLDERS

Fits Model Numbers	Length	Bit Dia.	Jobber	Order No.
All Bars	1 3/4"	1 1/32"	\$26.99	RL-1
Sleeve Cutter for All Bars	1 3/4"	1 1/32"	26.99	RL-1C

HOLDER WITH 3-EDGE TIP - Includes one RL-2T Tip

Fits Model Numbers	Length	Bit Dia.	Jobber	Order No.
All Bars (holder includes one tip)	1 3/4"	1 1/32"	\$34.99	RL-2H
Replacement Screw for RL-2H			4.49	RL-2S
Replacement Cutter Tip			12.99	RL-2T

STORM-VULCAN

1-EDGE CUTTER BIT FOR OE HOLDERS

Fits Model Numbers	Length	Bit Dia.	Jobber	Order No.
NS, BCG, BCT, 220, 260	3/4"	5/16"	\$45.99	S-1



1-Edge Replaceable Type

Tool holder with separate bit. Excellent cutting yet economical. Holds the cutter bit many times. When no longer usable, replace only the bit.

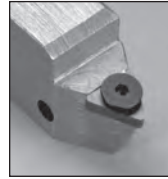

6-Edge Replaceable Type

Lowest-cost choice. Holders take 6-edge, replaceable tips. When one edge wears, turn to new surface. Never need to resharpen - just replace the tip.

Looking for Something Not Listed? Contact Goodson For Special Order Boring Bar Holders or Other Tooling
1-800-533-8010

Cutters enlarged for detail

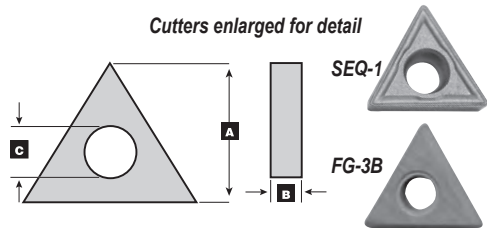

Replacement Tips & Parts

• Fit most boring bar holders

A	B	C	Edges	Jobber	Order No.
Standard Carbide					
.358"	.097"	.108"	3	\$19.99	SEQ-1
.345"	.094"	.140"	6	11.99	RT-6B
.360"	.094"	.124"	3	13.99	FG-3B
.327"	.094"	.140"	3	12.99	RL-2T
Titanium Coated					
.345"	.094"	.140"	6	\$12.99	RT-6BT

The more you buy, the more you save!

Order 10 or more tips, save 10% off jobber



Van Norman, Peterson or Kansas Instruments OE Catspaw Screws For 777S or PK-447S & 944S

Description	Jobber	Order No.
Catspaw Screws (1 each)		
For #1 Shoe (0.625"L)	\$11.99	800-114
For #2 Shoe (0.740"L)	12.99	800-115
For #3, 4 & 5 Shoe (0.940"L)	12.99	800-116



Fine Lapping Oil

- A light lap oil coat cools and lubricates
- Use with a variety of applications including diamond laps (below) and crocus cloth (p. 61)

Description	Jobber	Order No.
Very Fine Lap Oil (4 fl. oz.)	\$11.49	LP-LO-4
Very Fine Lap Oil (8 fl. oz.)	19.99	LP-LO-8

tech tips

from the techxperts™
Always use Lapping Oil with Diamond Laps

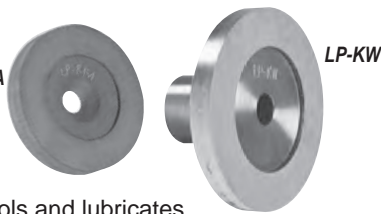

Diamond Laps

- A light lap oil coat cools and lubricates
- Remove carbide build-up with lint-free cloth and Dressing Stick while lap rotates

Machine	OD	ID	Jobber	Order No.
Rottler	1 3/4"	1/4"	\$249.99	LP-RFA
Kwik-Way	3 1/4"	1/2"	339.99	LP-KW
Dressing Stick			10.99	LP-DS

Other Diamond Laps available by Special Order

1 lb. Roll Copper or Stainless Steel O-Ring Wire

- Copper wire is .0403" diameter
- Stainless steel wire is .0410" diameter

Description	Jobber	Order No.
Copper	\$99.99	OWC-0403
Stainless Steel	84.99	OWS-041



Conversion Calculator

We've tried to convert as many SAE measurements to Metric (and vice versa) as possible. In some cases there hasn't been enough room.

If you need to convert a measurement, here are the formulas:

Starting Measurement	Conversion Formula	Converted Measurement
Inches (in)	Inches x 25.4	Millimeters (mm)
Feet (ft)	Feet x .3048	Meters (m)
Millimeters (mm)	Millimeters ÷ 25.4	Inches (in)
Fahrenheit (F)	(5 ÷ 9) x (F - 32)	Celsius (C)
Celsius (C)	(9 ÷ 5) x (C + 32)	Fahrenheit (F)

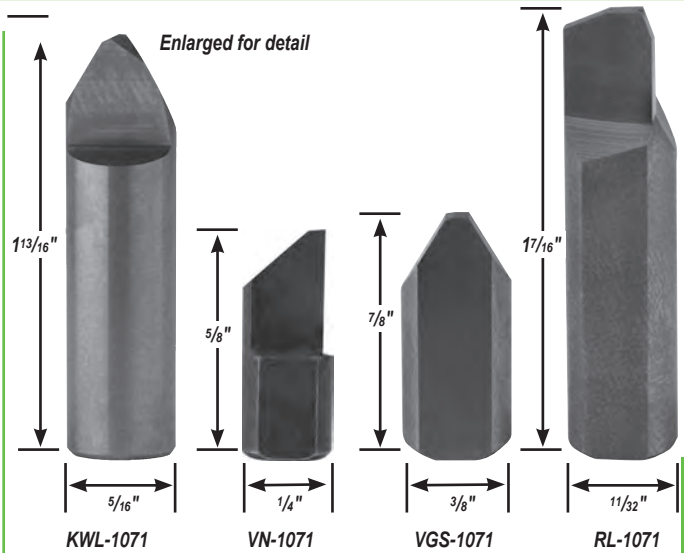

Solid Carbide Single Pass Boring Tools

- Greater fracture resistance than most carbide bits
- Ideal for hard alloys or interrupted cuts in automotive, high performance, marine, motorcycle and diesel engines

Description	Jobber	Order No.
Kwik-Way 5/16" x 1 13/64" L	\$79.99	KWL-1071
Van Norman 1/4" x 5/8" L	79.99	VN-1071
Van Norman 3/8" x 7/8" L	79.99	VGS-1071
Rottler 1 1/32" x 1 7/16" L	79.99	RL-1071

Tensioner Stop Block for Chrysler 2.7 DOHC

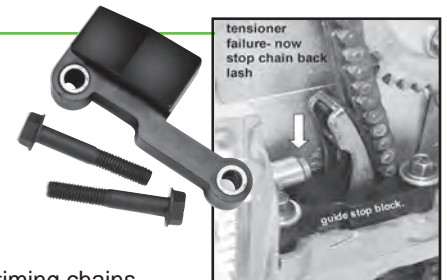

- Eliminate broken timing chains, bent valves and chain backlash
- For VIN code R, U & V
- Mechanically supports hydraulic adjusters
- Use with plunger screw or bottom plate tensioners
- For NEW Chain Tensioners
- Order No. DT-27 Jobber \$29.99

Boring Bar O-Ring Cutter Replaceable Tool Bits

- Cut grooves for O-rings to enhance gasket sealing for high-performance engines
- Machines a groove .037" wide • 1/4" Shank
- Fit Winona Van Norman, VN, Peterson, KI, Kwik-Way & Rottler Holders (available by special order)

Description	Application	Jobber	Order No.
Tool Bits	Standard	\$87.99	KWVN-57
	Premium	97.99	KWVN-57C6

tech tips
from the techxperts™

To avoid breakage, use the standard cutter on cast iron blocks only and the Premium cutter on hard blocks. **CAUTION:** Avoid column drop as this will break the tips as well.

CYLINDER HEAD REBUILDING
CLEANING, ASSEMBLY & SAFETY
SHORT BLOCK REBUILDING
CRANKSHAFT/ FLYWHEEL GRINDING
MISCELLANEOUS TOOLS & SUPPLIES
BRAKE SERVICE TOOLING
MEASURING TOOLS
V-TWIN & METRIC HARD PARTS

tech tips

from the techxperts™

- 1 - Extend the range of your hone with the Master Holder and Stone Supports on the bottom of page 89
- 2 - Use with 1/2" non-pistol grip drill (5/8" drill for AN-815 & GH-2555)
- 3 - Heavy Duty units can also be used in manual hone cabinets

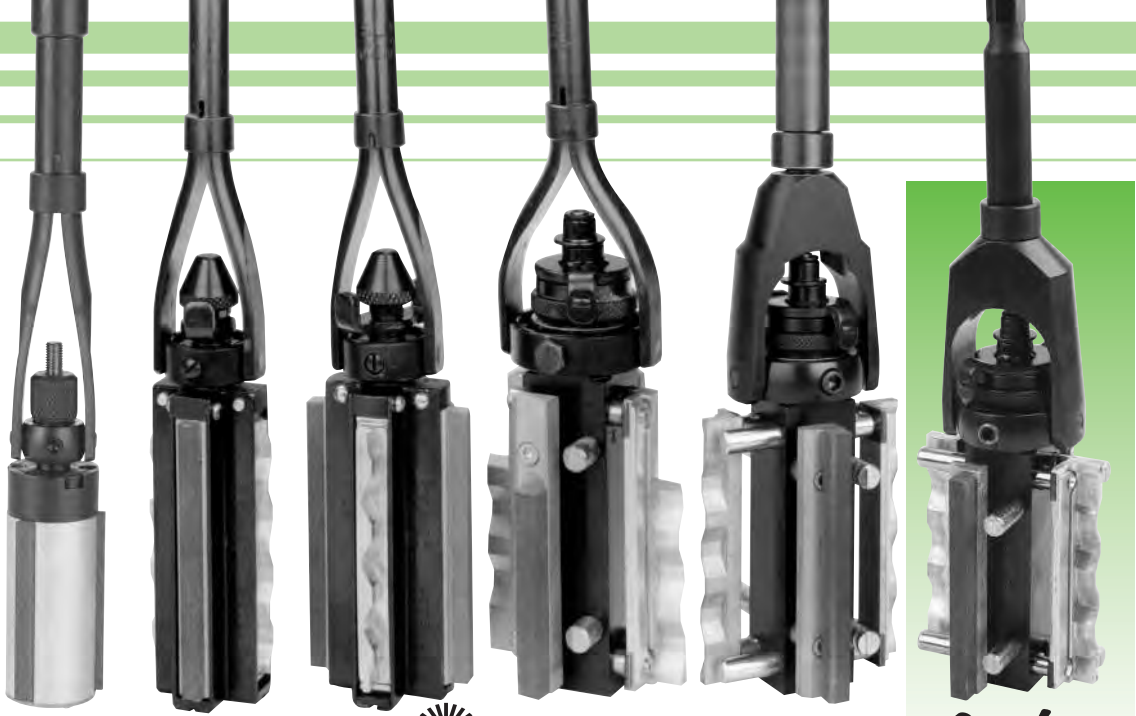
Goodson
exclusive
Portable Cylinder Hone Mandrels (stones sold separately)

Shaft extensions available.

	Junior Midget	Midget	Junior	Standard	Heavy-Duty	Heavy-Duty
Brand	Sunnen®	Sunnen®	Sunnen®	Sunnen®	Sunnen®	Goodson
Honing Range	1.25" - 1.75"	1.75" - 2.00"	2.00" - 2.60"	2.50" - 5.50"	2.50" - 5.50"	2.50" - 5.50"
Drive Shank	2.00" (incl.)	2.00" (incl.)	2.00" (incl.)	2.00" (incl.)	6.00" (incl.)	6.00" (incl.)
Drive Extension	12.00" (incl.)	12.00" (incl.)	12.00" (incl.)	12.00" (incl.)	12.00" (incl.)	12.00" (incl.)
Thread	3/8" - 14	3/8" - 14	3/8" - 14	3/8" - 14	3/8" - 11	3/8" - 11
Order No.	SNJ-10	SN-75	JN-95	AN-112	AN-815	GH-2555
Jobber	\$775.76	\$676.23	\$676.23	\$766.66	\$863.56	\$569.99

NOTE: Goodson is only authorized to ship Sunnen® products within the Americas



Worldwide Shipping

Water Based**Diamond Honing Coolant**

- Suitable for diamond honing on cast iron blocks
- Greatly reduces heat buildup in the block during honing
- Reduces amount of block cleaning after honing
- Disposal of used coolant is easy and more environmentally friendly than conventional honing oils
- 5 gallons makes up to 55 gallons of coolant
- Order No. **DHC-50** Jobber \$299.99

**Clear Mineral Based Honing Oil**

- Helps keep stones clean and free-cutting
- Ideal for portable hones and all makes of automotive honing machines
- Mixes easily with other brands, including Sunnen®
- **Not** water soluble



Size	Jobber	Order No.
1 Gal./3.78L	\$ 26.99	HO-10
5 Gal./18.9L	124.99	HO-50

Honing Stones

- Ideal for Cast Iron

Grit	Range	mm	Finish	Jobber	Order No.
For Sunnen® Junior Midget Hone (SNJ-10) 3 Stones & No Wipers					
150 Grit	1.25" - 1.44"	31.8-36.6	45 Ra	---	\$33.31 SNJ1-J45
	1.42" - 1.60"	36.1-40.6	45 Ra	---	33.31 SNJ2-J45
	1.58" - 1.77"	40.1-44.9	45 Ra	---	33.31 SNJ3-J45
400 Grit	1.25" - 1.44"	31.8-36.6	8 Ra	---	33.31 SNJ1-J87
	1.42" - 1.60"	36.1-40.6	8 Ra	---	33.31 SNJ2-J87
	1.58" - 1.77"	40.1-44.9	8 Ra	---	33.31 SNJ3-J87
For Sunnen® Midget Hone (SN-75) 2 Stones & 2 Wipers					
70 Grit	1.75" - 2.00"	44.5-50.8	120 Ra	SN-100	\$28.98 S18-J17
150 Grit	1.75" - 2.00"	44.5-50.8	45 Ra	SN-200	28.98 S18-J45
220 Grit	1.75" - 2.00"	44.5-50.8	32 Ra	SN-300	28.98 S18-J55
280 Grit	1.75" - 2.00"	44.5-50.8	20 Ra	SN-500	28.98 S18-J65
400Grit	1.75" - 2.00"	44.5-50.8	8 Ra	---	28.98 S18-J87
For Sunnen® Junior Hone (JN-95) 2 Stones & 2 Wipers					
70 Grit	2.00" - 2.20"	50.8-55.9	120 Ra	JN-100	\$28.98 T20-J17
	2.20" - 2.40"	55.9-60.9	120 Ra	JN-101	28.98 U22-J17
	2.40" - 2.60"	60.9-66.0	120 Ra	JN-102	28.98 V24-J17
150 Grit	2.00" - 2.20"	50.8-55.9	45 Ra	JN-200	28.98 T20-J45
	2.20" - 2.40"	55.9-60.9	45 Ra	JN-201	28.98 U22-J45
	2.40" - 2.60"	60.9-66.0	45 Ra	JN-202	28.98 V24-J45
220 Grit	2.00" - 2.20"	50.8-55.9	32 Ra	JN-300	28.98 T20-J55
	2.20" - 2.40"	55.9-60.9	32 Ra	JN-301	28.98 U22-J55
	2.40" - 2.60"	60.9-66.0	32 Ra	JN-302	28.98 V24-J55
280 Grit	2.00" - 2.20"	50.8-55.9	20 Ra	JN-500	28.98 T20-J65
	2.20" - 2.40"	55.9-60.9	20 Ra	JN-501	28.98 U22-J65
	2.40" - 2.60"	60.9-66.0	20 Ra	JN-502	28.98 V24-J65
400 Grit	2.00" - 2.20"	50.8-55.9	8 Ra	---	28.98 T20-J87
	2.20" - 2.40"	55.9-60.9	8 Ra	---	28.98 U22-J87
	2.40" - 2.60"	60.9-66.0	8 Ra	---	28.98 V24-J87



Goodson and Sunnen® Cylinder Honing Stones For all popular AN-style Honers and Hone Bodies

- Integral holder type Honing stone sets have 4 pieces: 2 holders with stones and 2 holders with aluminum wipers
- Fit Sunnen® AN Standard, AN Heavy-Duty and Goodson **GH-2555** hones
- Use with honing oil
- Stones for Short or Blind Holes are 2¹³/₁₆" long; all other stones are 4" long
- **Mix or Match 5 HN stones, Save 10% off jobber**

Grit	Bore Range		Usage	Finish	SUNNEN®			GOODSON			
	in	mm			Jobber	Old Order No.	New Order No.	Jobber 1+	Jobber 5+	Order No.	
70 Grit Roughing	2.5"-2.7"	63.5-68.6	Cast Iron	120 Ra	\$30.86	AN-115	G25-J17	\$29.49	\$26.54	HN-115S	
	2.7"-4.1"	68.6-104.1	Cast Iron	120 Ra	30.86	AN-100	M27-J17	29.49	26.54	HN-100S	
			Cast Iron	120 Ra	—	—	—	29.49	26.54	HN-100R¹	
	3.5"-5.5"	88.9-139.7	Short/Blind	120 Ra	34.11	AN-100-71	M27-J17-71	29.49	26.54	HN-102S	
			Harley / VW	120 Ra	43.91	AN-100F	AN-100F	29.49	26.54	HN-100F	
			Cast Iron	120 Ra	30.86	AN-101	N37-J17	29.49	26.54	HN-101S	
			Cast Iron	120 Ra	—	—	—	29.49	26.54	HN-101R¹	
	Use Master Holder & Sleeve Support	4.7"-15.0"	119.4-381	Short/Blind	120 Ra	34.11	AN-101-71	N37-J17-71	29.49	26.54	HN-104S
				Hard Sleeves	55 Ra	30.86	AN-131	N37-J11	29.49	26.54	HN-131S
				Cast Iron	120 Ra	30.86	AN-106	W47-J17	29.49	26.54	HN-106S
150 Grit Medium	2.5"-2.7"	63.5-68.6	Cast Iron	45 Ra	30.86	AN-215	G25-J45	29.49	26.54	HN-215S	
	2.7"-4.1"	68.6-104.1	Cast Iron	45 Ra	30.86	AN-200	M27-J45	29.49	26.54	HN-200S	
			Short/Blind	45 Ra	34.11	AN-200-71	M27-J45-71	29.49	26.54	HN-202S	
	3.5"-5.5"	88.9-139.7	Hard Sleeves	30 Ra	—	—	—	29.49	26.54	HN-230S	
			Cast Iron	45 Ra	30.86	AN-201	N37-J45	29.49	26.54	HN-201S	
			Short/Blind	45 Ra	34.11	AN-201-71	N37-J45-71	29.49	26.54	HN-204S	
	Use Master Holder & Sleeve Support	4.7"-15.0"	119.4-381.0	Hard Sleeves	30 Ra	30.86	AN-231	N37-J43	29.49	26.54	HN-231S
				Cast Iron	45 Ra	30.86	AN-206	W47-J45	29.49	26.54	HN-206S
				Hard Sleeves	30 Ra	30.86	AN-236	W47-J43	29.49	26.54	HN-236S
	220 Grit Finishing	2.7"-4.1"	68.6-104.1	Cast Iron	32 Ra	30.86	AN-300	M27-J55	29.49	26.54	HN-300S
Short/Blind				32 Ra	34.11	AN-300-71	M27-J55-71	29.49	26.54	HN-302S	
3.5"-5.5"		88.9-139.7	Cast Iron	32 Ra	30.86	AN-301	N37-J55	29.49	26.54	HN-301S	
			Short/Blind	32 Ra	34.11	AN-301-71	N37-J55-71	29.49	26.54	HN-304S	
Use Master Holder & Sleeve Support	4.7"-15.0"	119.4-381	Cast Iron	32 Ra	30.86	AN-306	W47-J55	29.49	26.54	HN-306S	
280 Grit Fine Finish	2.5"-2.7"	63.5-68.6	Cast Iron	20 Ra	30.86	AN-515	G25-J65	29.49	26.54	HN-515S	
	2.7"-4.1"	68.6-104.1	Cast Iron	20 Ra	30.86	AN-500	M27-J65	29.49	26.54	HN-500S	
			Short/Blind	20 Ra	34.11	AN-500-71	M27-J65-71	29.49	26.54	HN-502S	
	3.5"-5.5"	88.9-139.7	Hard Sleeves	12 Ra	30.86	AN-530	M27-J63	29.49	26.54	HN-530S	
			Cast Iron	20 Ra	30.86	AN-501	N37-J65	29.49	26.54	HN-501S	
			Short/Blind	20 Ra	34.11	AN-501-71	N37-J65-71	29.49	26.54	HN-504S	
	Use Master Holder & Sleeve Support	4.7"-15.0"	119.4-381.0	Hard Sleeves	12 Ra	—	—	—	29.49	26.54	HN-531S
Cast Iron				20 Ra	30.86	AN-536	W47-J63	29.49	26.54	HN-536S	
400 Grit Extra Fine Finish	2.5"-2.7"	63.5-68.6	Cast Iron	8 Ra	30.86	—	G25-J87	29.49	26.54	HN-615S	
	2.7"-4.1"	68.6-104.1	Cast Iron	8 Ra	30.86	—	M27-J87	29.49	26.54	HN-600S	
			Hard Sleeves	5 Ra	30.86	—	M27-J85	29.49	26.54	HN-630S	
	3.5"-5.5"	88.9-139.7	Cast Iron	8 Ra	30.86	—	N37-J87	29.49	26.54	HN-601S	
			Hard Sleeves	5 Ra	30.86	—	N37-J85	29.49	26.54	HN-631S	
Cork Polishing	2.5"-3.3"	63.5-83.8	Cast Iron*	2-3 Ra	47.32	—	G25-C05				
	3.3"-4.2"	83.8-106.7	Cast Iron*	2-3 Ra	73.85	—	MM33-C05				
	4.0"-5.6"	101.6-142.2	Cast Iron*	2-3 Ra	73.85	—	NN40-C05				

(*Cast Iron – 3 Ra., Hard Sleeves – 2 Ra., Steel– 3 Ra.)

¹Ruby Aluminum-Oxide abrasive for longer life in rough cutting use

SUNNEN® Master Holder & Stone Supports

- Holds one 4" stone set
- Stones sold separately
- AN-365 requires use of AN-260
- Larger sizes available upon special order

Master Holder		
Dia. Range	Jobber	Order No.
4.7"-7.0"	\$185.25	AN-355
6.0"-9.0"	191.78	AN-365
Stone Supports for AN-365		
6.0"-9.0"	\$135.39	AN-260

Note: Larger sizes available by special order.

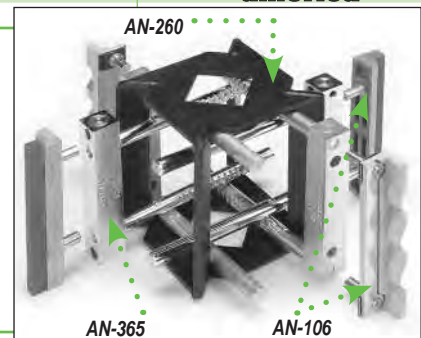

CYLINDER HEAD
REBUILDING
CLEANING,
ASSEMBLY & SAFETY
SHORT BLOCK
REBUILDING
GRANKSHAFT/
FLYWHEEL GRINDING
MISCELLANEOUS
TOOLS & SUPPLIES
BRAKE SERVICE
TOOLING
MEASURING
TOOLS
V-TWIN & METRIC
HARD PARTS

... another satisfied customer

"The thing I like about Goodson is you always have the correct, up-to-date tools."
 — ALC Machine, Santa Rosa, CA, Goodson customer since 1990

CYLINDER HEAD REBUILDING

CLEANING, ASSEMBLY & SAFETY

SHORT BLOCK REBUILDING

CRANKSHAFT/ FLYWHEEL GRINDING

MISCELLANEOUS TOOLS & SUPPLIES

BRAKE SERVICE TOOLING

MEASURING TOOLS

V-TWIN & METRIC HARD PARTS

Keyway Honing Stone Sets

- Two-stroke engines have intake and exhaust ports that interrupt the operation of your honing stone
- These stones allow the hone to pass the intake and exhaust ports while maintaining consistent pressure to remove material accurately and easily
- Use with any AN- or GH-series hone (p. 88)
- For Cast Iron



Grit	Range	mm	Finish	Type	Jobber	Order No.
150 Grit	2.5" - 3.3"	63.5 - 83.8	45 Ra	Alum.	\$56.22	GY25-J45
Medium	3.3" - 4.2"	83.8 - 106.7	45 Ra	Alum.	56.22	MY33-J45
280 Grit	2.5" - 3.3"	63.5 - 83.8	20 Ra	Brass	56.22	GY25-J65
Fine Finish	3.3" - 4.2"	83.8 - 106.7	20 Ra	Soft	56.22	MY33-J65
400 Grit	2.5" - 3.3"	63.5 - 83.8	8 Ra	Brass	56.22	GY25-J85
Extra Fine	3.3" - 4.2"	83.8 - 106.7	8 Ra	Soft	56.22	MY33-J85

EHU
type stones

GEHN type stones



Stones & Shoes for Sunnen Hone Machines

- Premium-quality replacements for all CV-616, and CK-10 hones equipped with Sunnen® Master Holder Sets
- Diameter Range: 4.125" - 5.000" (104.8 - 127.0mm)
- Use with Master Holder Set CK-3045A (sold separately)
- 2 stones per set

Stones			Goodson - 1 set		Sunnen - 6 sets	
Use	Grit	Finish	Jobber	Order No.	Jobber	Order No.
Hard Blocks	70	60 Ra	\$16.99	GEHN-116	\$110.11	EHN-116
Hard Blocks	220	22-32 Ra	16.99	GEHN-512	110.11	EHN-512
Air Cooled Cyl.	220	22-32 Ra	16.99	GEHN-518	110.11	EHN-518
Hard Blocks	70	60 Ra	16.99	GEHU-123	110.11	EHU-123
Roughing	70	60 Ra	16.99	GEHU-133	110.11	EHU-133
Hard Blocks	220	22-32 Ra	16.99	GEHU-518	110.11	EHU-518
Gen. Purp.	220	22-32 Ra	16.99	GEHU-525	110.11	EHU-525
Aluminum	220	30-36 Ra	16.99	GJHU-525	110.11	JHU-525
High Nickel	280	20-25 Ra	16.99	GJHU-623	110.11	JHU-623
Finishing	280	16-23 Ra	16.99	GJHU-625	110.11	JHU-625
High Nickel	400	7-14 Ra	16.99	GJHU-818	110.11	JHU-818
Aluminum	400	7-14 Ra	16.99	GJHU-820	110.11	JHU-820
Accessories			Qty.	Jobber	Order No.	
Sunnen® Master Holder Set			1	\$286.86	CK-3045A	
Sunnen® Centering Guide (includes CK-3070)			1	144.11	CK-3090A	
Sunnen® Guide Shoe & Screw Set			1	24.23	CK-3070	
Sunnen® Guide Shoe & Screw Set			1	36.83	CK-3120	
Goodson Wear Shoe			1	26.99	C-3070K	
Goodson Stabilizing Shoe			2	43.99	C-3120K	

For Rod Honing Stones and Shoes see page 93

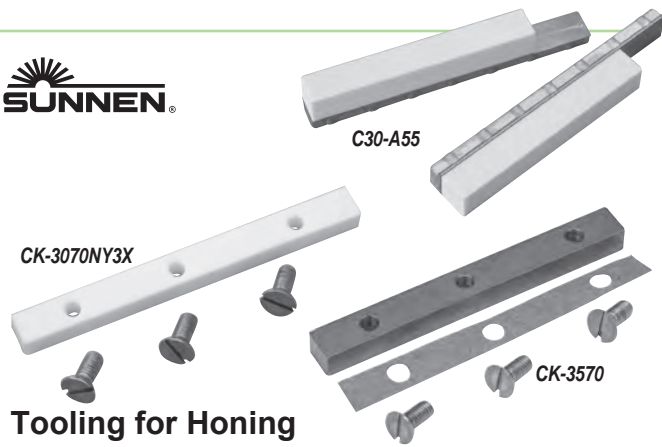

Tooling for Honing Dart Blocks & Ductile Sleeves

- Recommended for Dart™ Machinery
- Use with Sulfurated Rod Honing Oil (below)

Description	Jobber	Order No.
Honing Stone Sets For Portable Tooling		
80 Grit	\$31.35	N37-A25
220 Grit	31.35	N37-A55
280 Grit	30.86	N37-J65
400 Grit	44.68	MM33-J85
For CK/CV Type Machines		
80 Grit Stone Set (6)	\$110.11	C30-A25
150 Grit Stone Set (6)	110.11	C30-A45
220 Grit Stone Set (6)	110.11	C30-A55
280 Grit Stone Set (6)	110.11	C30-J65
400 Grit Stone Set (6)	110.11	C30-J85
Hardened Steel Guide Shoe (1)	192.58	CK-3570
Delron® Guide Shoe (1)	133.11	CK-3070NY3X
Goodson Brand Shoes For CK/CV Type Machines		
Hardened Steel Guide Shoe (1)	\$134.99	GCK-3570
Delron® Guide Shoe (1)	102.99	GCK-3070NY3X

tech tips For CK & CV Machines, **USE** use Hardened Steel and Delron from the techxperts™ shoes above (1 of each)

Ultra-Finish Plateau Hones



- Abrasive impregnated nylon bristles
- Ideal for high-performance rebuilding and rebuilding engines with low-tension rings • Superior plateau finish so rings will seal immediately
- Reduce break-in time
- Allow closer tolerances • 1 Pair

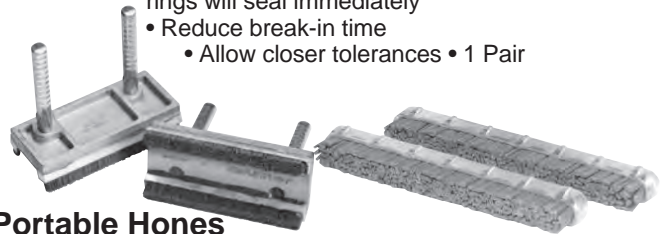

Portable Hones

- Fit AN- or GH- style hones
- Range: 3.78" to 4.68"
- Order No. **MM-PHT-731**
- Jobber \$351.37

CV/CK Hone Heads

- Range: 3.10" to 5.00"
- Order No. **C30-PHT-731**
- Jobber \$241.55

Sulfurated Honing Oil

- Includes additives for high pressure cutting

Size	Jobber	Order No.
1 gal./3.78L	\$ 38.99	RHO-10
5 gal./18.9L	189.99	RHO-50





82° 3" Dia. Chamfering Cones & Mandrel

- Chamfer sharp edges for safe piston and ring installation
- Handles all diameter cylinders or sleeves
- Fits 3/8" (9.53mm) or larger drill
- Kit (CC-100) includes mandrel and three 50 Grit Aluminum Oxide cones (CC-15)
- Due to manufacturing process, abrasive color may vary
- Aluminum-Oxide is a good general purpose abrasive suited for ferrous and non-ferrous metals
- Zirconium is a tough abrasive well suited for heavy stock removal on most metals



Description	Jobber	Order No.	Incl.
3" Top Dia. Chamfering Cone Kit	\$59.99	CC-100	▼
Replacement 3/8" Drill Adaptor	15.99	CC-100-1	x
Aluminum Oxide Chamfering Cones (red)	1+	5+	
40 Grit	\$ 9.99	\$8.99	CC-14
50 Grit	9.99	8.99	CC-15
80 Grit	9.99	8.99	CC-20
Premium Zirconia Chamfering Cones (blue)			
50 Grit	\$ 10.99	\$9.89	CCZ-15
80 Grit	10.99	9.89	CCZ-20

Mix & Match 5 Cones for Quantity Discount; Save 10% off Jobber

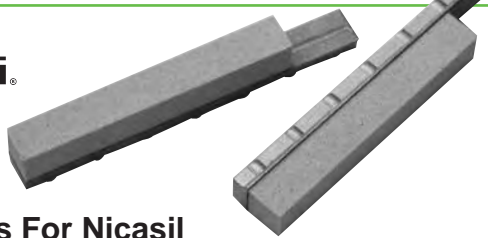

Honing Stone Sets For Nicasil

- For deglazing Nicasil with a CV/CK Honing Machine
- Diameter Range:
 - 3.0" - 5.0" (76.2-127.0mm) in standard automotive head
 - 2.6" - 3.5" (66.0-88.9mm) in junior head
- 150 grit aluminum oxide abrasive
- 2 stones per set; 6 sets per package
- Order No. EHU-412 Jobber \$110.11

Lisle® Honing Stone Sets

- Clip-on style mounts in seconds
- 5"/127mm long stones and wipers
- Each set contains two stones and two felt wipers
- Use dry

Replaces Lisle® No.	Grit	Order No.
15500	80	HL-80
15510	180	HL-180
15520	280	HL-280
15590	500	HL-500

Jobber per set \$18.99

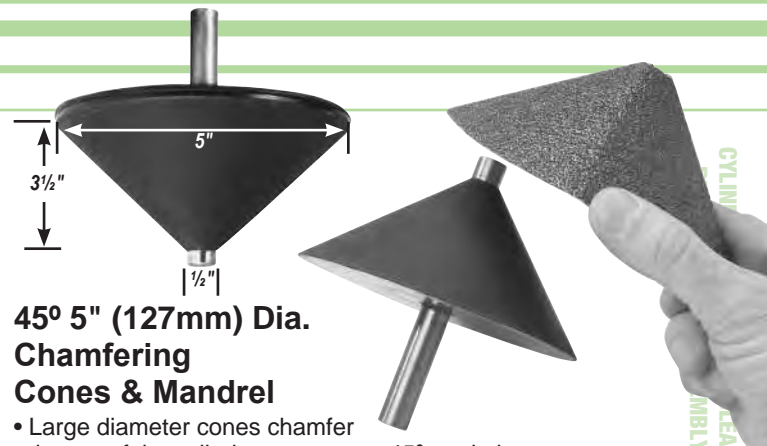

45° 5" (127mm) Dia. Chamfering Cones & Mandrel

- Large diameter cones chamfer the top of the cylinder to an exact 45° angle in one pass
- 1/2" (12.7mm) steel shank is permanently embedded in the cone base to ensure stability
- Cone height: 3/2" (88.9mm)
- Kit includes mandrel & one 36-grit cone (CC-30)
- Due to manufacturing process, abrasive color may vary
- Aluminum-Oxide is a good general purpose abrasive suited for ferrous and non-ferrous metals
- Zirconium is a tough abrasive well suited for heavy stock removal on most metals



Description	Jobber	Order No.	Incl.
5" Chamfering Cone Kit	\$154.99	CC-130	▼
Chamfering Cones	Abrasive	Grit	1+ 5+
	Aluminum Oxide (red)	36	\$ 9.99 \$8.99
		50	9.99 8.99
		80	9.99 8.99
	Premium Zirconia (blue)	36	11.99 10.79
		50	11.99 10.79
		80	11.99 10.79

Mix & Match 5 Cones for Quantity Discount; Save 10% off Jobber



Honing Stones for Nicasil

- Deglaze Nicasil cylinders with portable hones
- 150 Grit Aluminum-Oxide abrasive
- Resizing cylinders requires diamond abrasive
- For AN-style and GH-style hones (page 88)

Inches	Metric	Jobber	Order No.
2.500" - 3.300"	(64 - 84mm)	\$44.17	GG25-A43
3.300" - 4.200"	(84 - 107mm)	44.17	MM33-A43
4.000" - 5.600"	(102 - 142mm)	44.17	NN40-A43

Order 3 or more Flex-Hones® (mix & match) and save 10% off jobber



Standard Duty 240 Grit Aluminum Oxide Flex-Hones® For Nicasil

Inch	mm	Jobber	Order No.
2 1/4"	57.2	\$41.99	BA-225240
2 3/8"	60.2	43.99	BA-237240
2 1/2"	63.5	44.99	BA-250240
2 5/8"	66.5	46.99	BA-262240
2 3/4"	69.8	48.99	BA-275240
3"	76.2	56.99	BA-300240

Inch	mm	Jobber	Order No.
3 1/4"	82.5	\$63.99	BA-325240
3 1/2"	88.9	68.99	BA-350240
3 3/4"	95.3	73.99	BA-375240
4"	104.8	77.99	BA-418240
4 3/8"	117.5	86.99	BA-462240

More Flex-Hones® on page 85

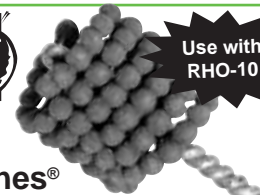

Use with RHO-10

CYLINDER REPAIRING, REBUILDING
 SHORT BLOCK REBUILDING
 CRANKSHAFT/ FLYWHEEL GRINDING
 MISCELLANEOUS TOOLS & SUPPLIES
 BRAKE SERVICE TOOLING
 MEASURING TOOLS
 TWIN & METRIC HARD PARTS



"Our tech staff can help you solve problems fast. Call us with questions about product applications, machining processes, longer tool life, improving efficiency and any other technical topic. We're here to help."

- Paul, Goodson Customer & Tech Service - 3 years of service

CYLINDER HEAD
REBUILDING

CLEANING,
ASSEMBLY SAFETY

SHORT BLOCK
REBUILDING

CRANKSHAFT/
FLYWHEEL GRINDING

MISCELLANEOUS
TOOLS & SUPPLIES

BRAKE SERVICE
TOOLING

MEASURING
TOOLS

V-TWIN & METRIC
HARD PARTS



Stones & Replacement Parts For CR-Series Mandrels

- SunnEN honing stones are sold as pairs while Goodson honing stones are sold individually

Honing Stones for Manual Honing*

Fit Mandrels	Finish	Jobber	SunnEN Order No.	Jobber	Goodson Order No.
CR-1450 to 1750	Medium	\$29.56	CR-2	-----	-----
	Fine	29.56	CR-4	-----	-----
CR-1900 & Larger	Aluminum/ Titanium	29.56	CR-9	-----	-----
	Roughing	29.56	CR-10	\$14.49	HC-10
	Medium	29.56	CR-12	14.49	HC-12
	Fine	29.56	CR-14	14.49	HC-14

For Power Hone	Roughing	Jobber	SunnEN Order No.	Jobber	Goodson Order No.
For Power Hone	Roughing	33.96	CR-10N	-----	-----

Guide Shoes (2 per box)					
CR-1450 to 1750	Die Cast	\$11.72	CR-40D	-----	-----
CR-1900 & larger	Die Cast	12.39	CR-50D	-----	-----
	Bronze	55.20	CR-50B	-----	-----

Wedge & Wedge Plates					
CR-1450 to 1750	Wedge	\$97.32	CR-70	-----	-----
	Small Plate	41.91	CR-75	-----	-----
	Large Plate	41.91	CR-85	-----	-----
CR-1900 to 2500	Wedge	57.57	CR-100	-----	-----
CR-1900 & Larger	Small Plate	48.32	CR-110	-----	-----
	Large Plate	48.32	CR-120	-----	-----
CR-2900	Wedge	74.57	CR-200	-----	-----

SunnEN® Tension Block For CR-2900 & Larger		\$ 16.37	LN-1337A		
SunnEN® Shoe Clamps (4 + screws) for CR-1900 & larger		108.71	CR-45A		

*SunnEN® honing stones include 2/box, Goodson include 1/box

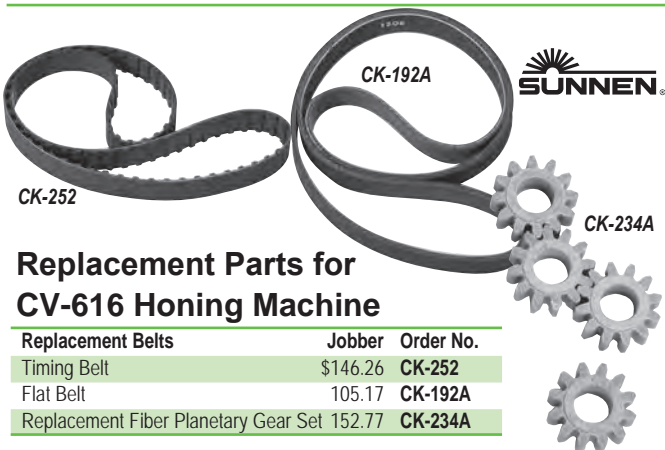

Replacement Parts for CV-616 Honing Machine

Replacement Belts	Jobber	Order No.
Timing Belt	\$146.26	CK-252
Flat Belt	105.17	CK-192A
Replacement Fiber Planetary Gear Set	152.77	CK-234A

Mandrel Driver for Portable Use of CR-, PL- and ML-Series Honers

- Ideal for spindle bushings mounted on axles and other jobs that can't be taken to the honing machine
- For holes 3/4"/19.05mm ID and larger, where length is at least 3 times the diameter
- ID Range: .744" - 3.875"/19mm - 98mm
- Graduated adjustment knob advances and retracts stones • 275 - 450 RPM range
- Use with any 1/2"/12.7mm drill or larger
- Order No. **GGN-150** Jobber \$1059.39



Rod Honing Oil

- Includes additives for high pressure cutting
- Keeps stones clean and free-cutting during rod reconditioning, pin fitting and other honing applications
- Will mix with other honing oils (including SunnEN®)



Size	Jobber	Order No.
1 gal./3.78L	\$ 38.99	RHO-10
5 gal./18.9L	189.99	RHO-50



Goodson Belts for SunnEN® Rod Honing Machines

- Top-quality belts for long life

tech tips

from the techexperts™
You must measure the belt you are replacing. Ordering is based on length, not machine model. If your belt size doesn't match one in the chart, order the next size down. For example, if your belt measures 72 1/2", order the 70" Oil Pump Belt. Belts stretch over time so the shorter belt will fit.



Size	Jobber	Order No.
Oil Pump Belts (.250" dia.)		
70"/1.78m	\$117.99	RHB-70
74"/1.88m	117.99	RHB-74
85"/2.16m	117.99	RHB-85
109"/2.77m	136.99	RHB-109
Flat Belts		
45 1/2" x 5/8"/1155.7x15.9mm	\$144.99	RHFB-45
46 1/2" x 5/8"/1181.1x15.9mm	144.99	RHFB-46

Rod Honing Stones & Mandrels



KL-Series Connecting Rod Lifetime Honing Unit Mandrel Adaptor

- Mandrel Adaptor comes with retainer
- Order No. **AK20-A** Jobber \$51.91



Rod Honing Stones, Guide Shoes & Replacement Parts

- Premium-quality • Choose Goodson or Sunnen®

SL
Stones



HP / PL
Stones

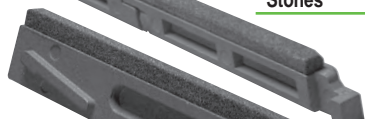

HM / ML
Stones



HK / KL
Stones

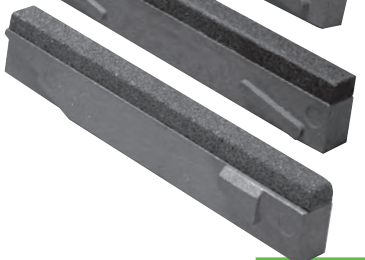

Bronze
Guide
Shoes

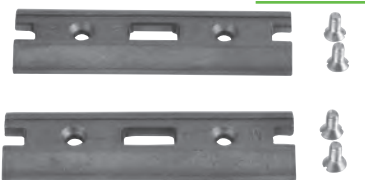

Stones	Use	Goodson			Sunnen®		Old	
		Jobber	Order No.	Qty.	Jobber	Order No.	Order No.	Qty.
For Sunnen® SL720 - SL2300 Mandrel								
	Roughing					\$126.09	SL-5	6
	General Purpose				WorldwideShipping	126.09	SL-7	6
	Finishing					126.09	SL-13	6
For Sunnen® PL Series Mandrel								
	Roughing	\$10.49	HP-5	1	\$105.45	P28-J27	PL-5	12
	General Purpose	10.49	HP-7	1	105.45	P28-J47	PL-7	12
	Finishing	10.49	HP-13	1	105.45	P28-J67	PL-13	12
For Sunnen® ML Series Mandrel								
	Roughing	\$9.49	HM-5	1	\$98.79	P20-J25	ML-5	12
	General Purpose	9.49	HM-7	1	98.79	P20-J47	ML-7	12
	Finishing	9.49	HM-13	1	98.79	P20-J67	ML-13	12
For Sunnen® KL Series Mandrel								
	Roughing	\$9.49	HK-5	1	\$98.79	K20-J25	KL-5	12
	General Purpose	9.49	HK-7	1	98.79	K20-J47	KL-7	12
	Finishing	9.49	HK-13	1	98.79	K20-J67	KL-13	12
	Steel	—	—	—	98.79	K20-A69	KL-14	12
Bronze Guide Shoes			Jobber	Order No.	Qty.	Jobber	Order No.	Qty.
For Sunnen® KL and ML Series Mandrel								
	.775"-.805"	19.7-20.4mm	—	—	—	\$54.79	UA-B	2
	.838"-.899"	21.3-22.8mm	—	—	—	54.79	UB-B	2
	.900"-.993"	22.9-25.2mm	—	—	—	54.79	UC-B	2
	.994"-1.125"	25.2-28.6mm	—	—	—	54.79	UD-B	2
	1.119"-1.250"	28.4-31.8mm	—	—	—	54.79	UE-B	2
Note: Bronze guide shoes outlast die cast 6 to 1.								
Zinc Alloy Guide Shoes			Jobber	Order No.	Qty.	Jobber	Order No.	Qty.
For Sunnen® PL and ML Series Mandrel								
	1.355" - 1.500"	34.4-38.1mm	—	—	—	\$26.01	WC-D	2
	1.480" - 1.625"	37.6- 41.3mm	—	—	—	26.01	WD-D	2
	1.730" - 2.000"	43.9- 50.8mm	—	—	—	26.01	WE-D	2



When cutting action of your honing stone slows down, a light stroke with the diamond dresser breaks the glaze and restores honing efficiency. Especially recommended for rod reconditioning. Consists of diamond stone on a sturdy metal holder with a chain for fastening it to the honing machine.



Diamond Stone Dresser

- Diamond stone on durable metal tool
- Order No. **MAN-700**
- Jobber \$104.95

tech tips
from the techxperts™

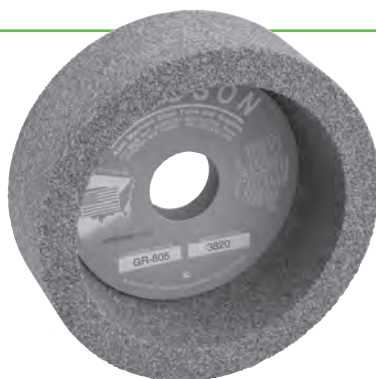

Rod & Cap Grinding Wheels

- Fits Sunnen® Rod and Cap Grinding Machines
- Recessed design
- Size: 6" x 2" x 1 1/4" (152.4 x 50.8 x 31.8mm)
- Order No. **GR-805** Jobber \$119.99



Rod & Cap Grinding Wheels

- For Sunnen® and other popular brand cap grinders
- Fits CRG 700, 750, 770, 780, 805 & 920K
- Softer than GR-805 • 6" x 2" x 1 1/4"
- Order No. **F343793** Jobber \$89.99

CYLINDER HEAD
REBUILDING

ASSEMBLY & SAFETY

SHORT BLOCK
REBUILDING

CRANKSHAFT/
FLYWHEEL GRINDING

MISCELLANEOUS
TOOLS & SUPPLIES

BRAKE SERVICE
TOOLING

MEASURING
TOOLS

V-TWIN & METRIC
HARD PARTS

"We offer every customer the opportunity to open a Goodson account for faster, easier ordering and to save you money on C.O.D. shipments. Call today for details!"

- Diane, Goodson Customer File Maintenance - 21 years of service

CYLINDER HEAD
REBUILDING

CLEANING,
ASSEMBLY & SAFETY

SHORT BLOCK
REBUILDING

CRANKSHAFT/
FLYWHEEL GRINDING

MISCELLANEOUS
TOOLS & SUPPLIES

BRAKE SERVICE
TOOLING

MEASURING
TOOLS

V-TWIN & METRIC
HARD PARTS

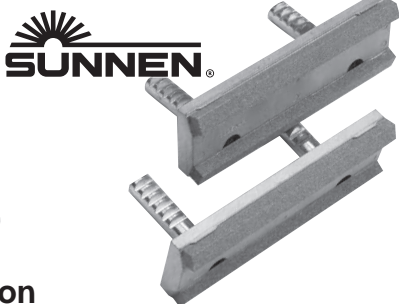

Hone High-Silicon Aluminum Alloy Blocks With Ease – Honing Stones & Silicon Compound

- Stones fit both the Sunnen® AN-112 and AN-815 and the Goodson GH-2555 Portable Honing Mandrels
- Use each stone set progressively until the final bore size is achieved • For Hone Diameter: 3.3" to 4.2"
- To create the final condition, coat the felt set and the honed cylinder surface with the Silicon Compound (AN-30) and lap the cylinders
- After completion, the cylinder will have a dull matte finish
- Piston and rings will ride on silicon instead of aluminum
- Silicon Compound 1 lb. / 450g

Description	Jobber	Order No.
Roughing (280 grit)	\$44.68	MM33-J63
Finishing (400 grit)	44.68	MM33-J85
Polishing (600 grit)	73.81	MM33-CO5
Felt Set	76.10	MM33-FO5
Silicon Compound	69.78	AN-30



Mandrel Driver for Line Honing Machines

- For Sunnen® CH-100 & similar line honing machines
- Graduated adjustment knob advances and retracts honing stones
- Quick release lever allows hone removal and installation without resetting
- Stone pressure adjusts with dial
- Automatically advances stones during honing
- **NOT** for portable honing applications
- Order No. CH-75A Jobber \$1268.48

tech tips

Right Hand Rotation Only.

For best results, keep your RPM about the same as your hone RPM, use the same rate of speed from the techxperts™ and number of strokes per minute.

Ultra-Finish Plateau Soft Hones

- Remove microscopic peaks and scuffs without enlarging bores
- Use with a portable drill
- Abrasive impregnated nylon bristles
- Ideal for high-performance engine rebuilding and for engines that use low-tension rings
- Use **after** honing
- Gives a superior plateau finish so rings seal immediately, reducing break-in time
- Allows closer tolerances for improved compression, better oil control, lower emissions
- For best results, use liberal amounts of honing oil (**HO-50**, pg. 76) • **NOT** interchangeable with Flex-Hones®



Hole Diameter Range	Hone	Head	Overall		
in	mm	Dia.	Length	Length	Jobber Order No.
.875"-1.00"	22-25	1.250"	2.00"	10.00"	\$47.99 UF-100
1.00"-1.25"	25-32	1.500"	2.00"	10.00"	51.99 UF-125
1.25"-1.75"	32-45	2.000"	2.00"	10.00"	51.99 UF-175
1.75"-2.25"	45-57	2.500"	2.00"	10.00"	54.99 UF-200
2.25"-2.75"	57-70	3.000"	3.00"	10.00"	54.99 UF-250
2.50"-3.00"	63-76	3.500"	4.00"	14.00"	54.99 UF-300
3.00"-3.50"	76-89	4.000"	4.00"	14.00"	66.99 UF-350
3.50"-4.00"	89-102	4.500"	4.00"	14.00"	66.99 UF-400
4.00"-4.50"	102-114	5.000"	5.00"	14.00"	66.99 UF-450
4.50"-5.00"	114-127	5.500"	5.00"	14.00"	66.99 UF-500

Valve Guide Plateau Hones on page 39



Line Hone Mandrels, Stones & Shoes

- For the Sunnen® CH-100, CHV-31, CH-20 & CH-40 Line Honing Machines
- Hone unit includes 10 stones and 20 shoes (replacement stones & shoes available)
- Stones for Aluminum blocks (RY24-J45) are softer than those for cast iron (RY24-J49)
- Additional hone units, stones and shoes are also available by special order

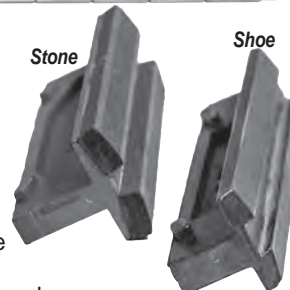

Description		Jobber	Order No.
Hone Unit	Diameter Range	Stone Length	Shipping Weight
	2.40" to 2.70"	33.75"	40 lbs
	2.70" to 3.00"	33.75"	45 lbs
	3.00" to 3.50"	33.75"	50 lbs
Replacement Stones — 5 per box (Requires 10 stones)			
	Recommended Application	Cast Iron	\$114.51
		Aluminum	114.51
Replacement Shoes — 10 per box (Requires 20 shoes)			
	Fit 10RY-2400G & 10RY2700G	\$129.50	RG-D
	Fit 10RY-3000H	132.27	RH-D

Goodson is now
Authorized to Ship
Sunnen Automotive
Products into Canada

Rod & Piston Work

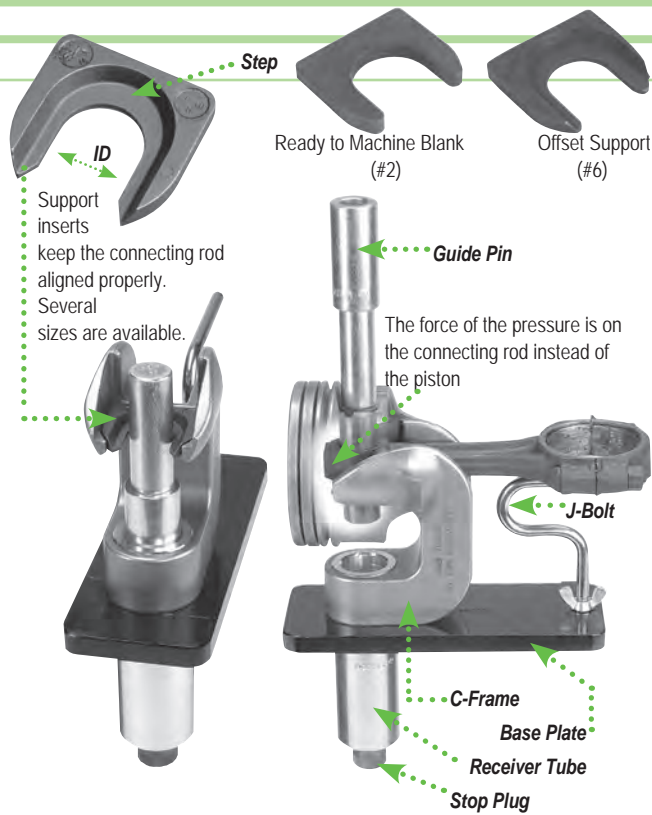

Piston Pin Removal Fixture

- Use to remove or install interference fit piston pins
- Force of removal is against the piston pin and connecting rod – no pressure is exerted on the piston itself
- Tool to fit most popular engines with pin diameters of 0.859" through 1.087"
- Replacement Support Inserts & Guide Pins sold separately



For Small Block Chevy use Support Insert #1 or Offset #6, for Big Block Chevy, use Support Insert #5, Support #2 is a blank, ready to be machined to your exact specifications.

Description	ID	Step	Jobber	Order No.	Incl.
Complete Kit			\$1079.99	PPE-7082	▼
Replacement C-Frame			399.99	PPE-302186	x
Replacement Support Inserts	#1	0.945" .100"	47.99	PPE-39889	x
	#2	1.110" .275"	47.99	PPE-39890	x
	#3	1.000" .182"	47.99	PPE-39888	x
	#4	1.110" .182"	47.99	PPE-39886	x
	#5	1.000" .100"	47.99	PPE-39887	x
	#6	0.945" .100"	47.99	PPE-39822	x
Replacement Guide Pins	0.859"		36.99	PPE-17940	x
	0.897"		43.99	PPE-17936	x
	0.926"		36.99	PPE-17937	x
	0.970"		36.99	PPE-17938	x
	0.992"		36.99	PPE-17939	x
	1.032"		36.99	PPE-17941	x
	1.055"		36.99	PPE-17942	x
	1.087"		36.99	PPE-18729	x
Replacement Parts					
J" Bolt (Rear Support)			\$29.99	PPE-302224	x
Wing Nut			2.19	PPE-10588	x
1 1/2" / 30.2mm Stop Plug			44.99	PPE-17830D	x
Base Plate			107.99	PPE-17929	x
Receiving Tube			53.99	PPE-17931B	x
Body Guide			54.99	PPE-17932B	x
5/2" / 139.7mm Spring			10.49	PPE-17934	x
Guide Pin Driver			26.99	PPE-17935	x
1 1/2" / 41.3mm External Spiral Lock			12.99	PPE-17945	x

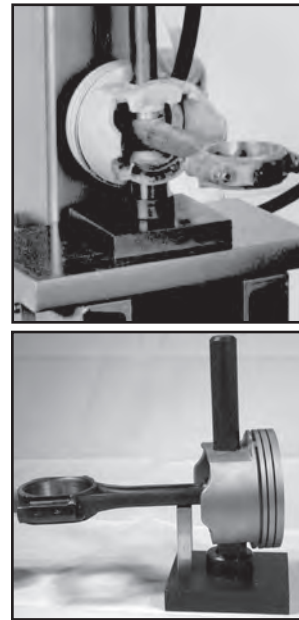

Universal Piston Pin Press-Out Tool

- Use with a shop press
- Top quality steel tooling
- Standard set handles most applications
- You can modify for individual needs

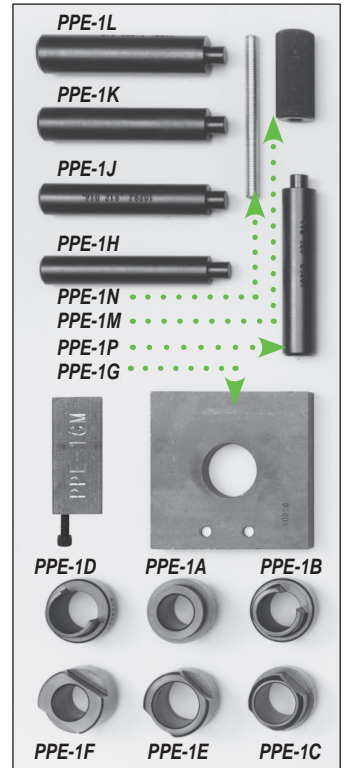

Description	Jobber	Order No.	Incl.
Piston Pin Extractor Kit	\$359.99	PPE-1	▼
Piston Support Fixtures			
.800" hole	29.99	PPE-1A	x
.865" hole	29.99	PPE-1F	x
.950" hole	29.99	PPE-1B	x
1.010" hole	29.99	PPE-1C	x
1.010" hole	29.99	PPE-1D	x
1.110" hole	29.99	PPE-1E	x
Fixture Base Block (4" x 4" x 3/4")	\$45.99	PPE-1G	x
Pin Pressing Drifts			
.760" dia.	20.99	PPE-1H	x
.812" dia.	20.99	PPE-1J	x
.875" dia.	20.99	PPE-1K	x
1.000" dia.	20.99	PPE-1L	x
Tapped Handle	19.99	PPE-1M	x
Threaded Rod	9.99	PPE-1N	x
Threaded Adaptor	16.99	PPE-1P	x
Rod Support	20.79	PPE-1GM	x

Kit includes the rod support for tapered boss pistons

GOODSON Rod Support for Sunnen® Pin Press Tooling

- Remove late model connecting rods from tapered boss pistons
- Aluminum construction prevents connecting rod damage • Fits B-162 Pin Press Reducing Ring

Description	Jobber	Order No.
Rod Support	\$62.99	BRS-130
Pin Press Reducing Ring	99.99	B-162

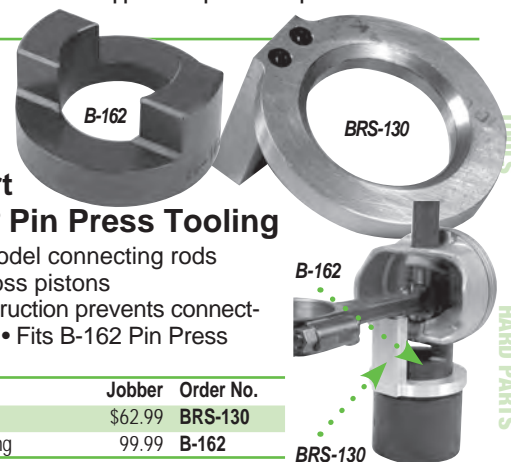

CYLINDER HEAD REBUILDING
CLEANING, ASSEMBLY & SAFETY
SHORT BLOCK REBUILDING
CRANKSHAFT/ FLYWHEEL GRINDING
MISCELLANEOUS TOOLS & SUPPLIES
BRAKE SERVICE TOOLING
MEASURING TOOLS
V-TWIN & METRIC HARD PARTS

... another satisfied customer

"This tool works!"

- Dennis Terrill, Terrill Motor Machine, Fort Lauderdale, FL, Goodson customer since 1990

CYLINDER HEAD
REBUILDING

CLEANING,
ASSEMBLY & SAFETY

SHORT BLOCK
REBUILDING

CRANKSHAFT/
FLYWHEEL GRINDING

MISCELLANEOUS
TOOLS & SUPPLIES

BRAKE SERVICE
TOOLING

MEASURING
TOOLS

V-TWIN & METRIC
HARD PARTS

Standard Wrist Pin Bushing Driver sizes range from 25mm to 54mm.

If we don't have the size you're looking for in the chart below, choose the next size up and turn it down on your lathe to the exact size you require.



made in america

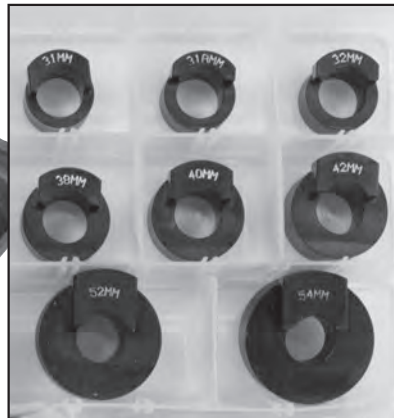

sized for diesel

Universal Tapered Pin Bushing Press Kit For Light & Medium Duty Diesel Engines

This press kit is specially designed to remove and replace tapered bushings in most common light to medium duty diesel applications. Don't spend time making a fixture that's dedicated to a single size. Our Tapered Pin Bushing Press Kit is ready to go when you receive it.

Description	Jobber	Order No.	Includes
Complete Wrist Pin Bushing Press Kit	\$1499.99	TB-KIT	▼
Wrist Pin Press Base (select drivers below)	879.99	TB-BASE	▼ x
Press Tube - Small (27x21x120mm)	45.99	TPT-SM	x
Press Tube - Large (30x31x110mm)	45.99	TPT-LG	x
Wrist Pin Ring (50x5x20/26mm)	19.99	WPR-001	x
Wrist Pin Parallels (2) 8x10x50mm	29.99	WPP-2	x
Extended Mandrel (8 1/2" long)	99.99	TB-MANDREL	x

Wrist Pin Bushing Drivers sold by dimension, not application

MM	Nominal	Actual	Step	Jobber	Order No.	Includes
25	1.000"	0.957"	0.063"	\$64.99	TBD-25	x
26	1.063"	0.990"	0.058"	64.99	TBD-26	x
27	1.060"	1.032"	0.067"	64.99	TBD-27	x
28	1.100"	1.006"	0.055"	64.99	TBD-28	x
30	1.180"	1.102"	0.075"	64.99	TBD-30	x
31	1.220"	1.158"	0.090"	64.99	TBD-31	x
31	1.220"	1.198"	0.067"	64.99	TBD-31A	x
32	1.260"	1.222"	0.078"	64.99	TBD-32	x
33	1.300"	1.268"	0.068"	64.99	TBD-33	x
34	1.340"	1.304"	0.073"	64.99	TBD-34	x
36	1.420"	1.377"	0.075"	64.99	TBD-36	x
38	1.500"	1.458"	0.076"	64.99	TBD-38	x
40	1.570"	1.554"	0.068"	64.99	TBD-40	x
42	1.650"	1.614"	0.097"	64.99	TBD-42	x
45	1.770"	1.742"	0.089"	64.99	TBD-45	x
46	1.810"	1.772"	0.108"	64.99	TBD-46	x
50	1.970"	1.940"	0.083"	64.99	TBD-50	x
52	2.050"	2.012"	0.114"	64.99	TBD-52	x
54	2.130"	2.099"	0.081"	64.99	TBD-54	x
Goodson Press Fit Lube (6 oz. Aerosol can)				13.99	PFL-200*	
Deburring Tool				23.99	DT-6	

*Hazardous Goods Fees Apply When Shipped Air

Choosing A Driver

1. Measure the wrist pin diameter.
2. Select a driver from the chart at right that is .030" to .040" smaller.
3. Measure the thickness of the bushing.
4. Select the driver with a Step size that is 50% to 60% of the bushing thickness.

tech tips
from the techxperts™

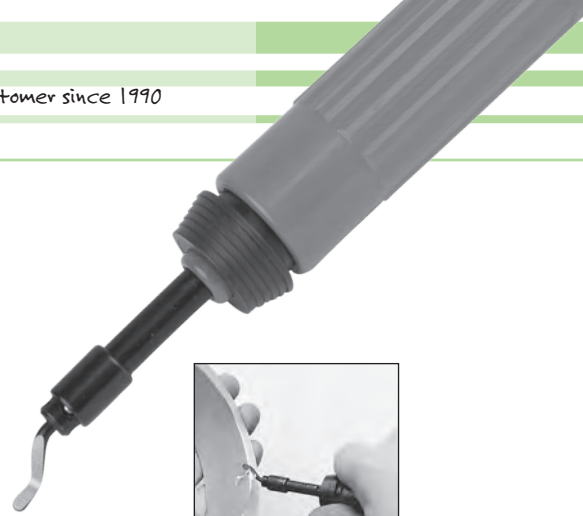
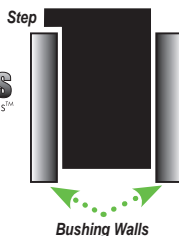

Deburring Tool

- Swivel tool chamfers sharp, machined edges, bolt holes, and much more
- DT-6 includes cutters for aluminum and cast iron

Description	Jobber	Order No.
Deburring Tool	\$23.99	DT-6
Replacement Cutters		
Steel/Aluminum	\$6.49	DT-10
Cast Iron/Brass	6.49	DT-20

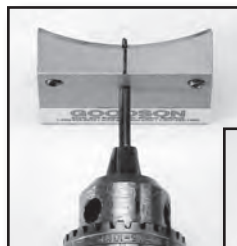

Gas Porting Tools for High Performance

- Virtually eliminate side ring clearance by drilling gas ports in your piston ring lands
 - These tiny ports apply compression pressure directly to the back of the ring, pushing it against the cylinder wall with greater force while minimizing compression leakage
 - Gas ports work best with piston-compression heights of 1.2" or less on engines running at high rpm (7,000 or higher)
 - This simple tool kit take the guess-work out of gas porting and include everything you'll need to get started
 - The complete kit includes: Drill Fixture, Depth Bushing and one Drill Bit
- US Patent No. US D617,664 S**

Description	Jobber	Order No.
Gas Porting Tool Kits	\$109.99	GPT-043
Replacement Drill Bits (5 Pack)	8.99	GPT-040-DB
Gas Porting Tool Kits	109.99	GPT-062
Replacement Drill Bits (5 Pack)	8.99	GPT-062-DB

Rod & Piston Work

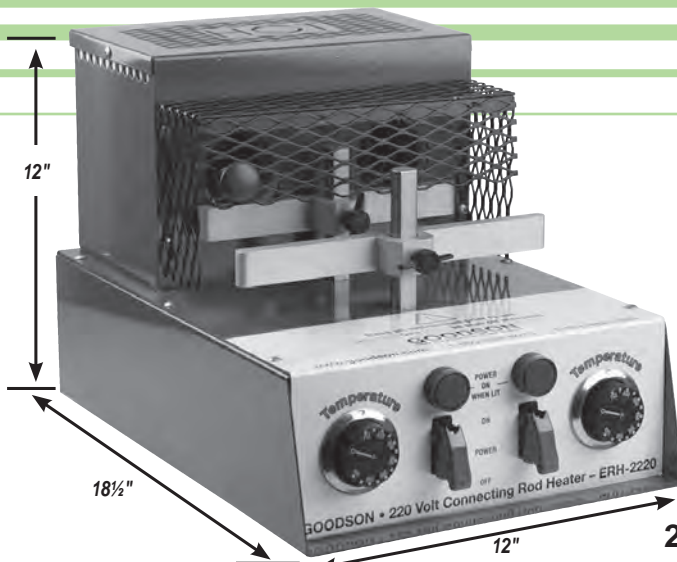

Toggle switches with flip-up covers to prevent accidental activation. LED lamps indicate when power is active.



Heating elements operate on separate thermostats.

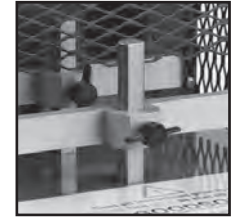

Adjustable rod supports accommodate most automotive connecting rods.

made in america

220V, Single-Phase Electric Rod Heater

- Includes a digital timer and 450° temperature crayon
- Double wall insulated heat chamber with safety screen
- Vented top for better performance
- Powder-coated heavy-gauge steel housing for long life

Gauntlet Style Heat & Flame Resistant Gloves

- Heavy lined red terry-cloth • 13½" Long
- Safe to 450°F / 232.2°C
- Order No. **HRF-300** Jobber \$37.99

Temperature Indicating Crayon

- Mark the workpiece before heating
- Melts when temperature is reached

Melting Point	Jobber	Order
450°F / 232.22°C	\$23.99	TIC-450
500°F / 260.00°C	23.99	TIC-500
600°F / 315.56°C	23.99	TIC-600

Description	Jobber	Order No.	Incl.
220V, 50/60 Hz Single Phase Electric Rod Heater	\$1299.99	ERH-2220	▼
Digital Read-Out Timer (battery included)	17.99	ERH-TIMER	x
Replacement Toggle Switch (ea.)	19.99	ERH-SWITCH	
Replacement Toggle Switch Guard (ea.)	49.99	ERH-TSG	
Replacement Thermostat (ea.)	111.99	ERH-THERM	
Replacement Heater Coil (ea.)	99.99	ERH-COIL	
Replacement LED Light Assembly (ea.)	49.99	ERH-LED	
Replacement Bezel Knob (ea.)	24.99	ERH-KNOB	
Replacement Thumbscrew (ea.)	8.99	ERH-TST	
450° Melting Point Temperature Indicator Crayon	23.99	TIC-450	x
Piston Pin Installation Fixture	109.99	PIF-25	

made in america



Assemble 8 rods & pistons in as little as 5 minutes

Propane Fired Rod Heater

- Needs no warm-up time – start assembling rods and pistons almost immediately
- Heats piston pin ends so fast the rest of the rod stays cool
- Minimal cool down time after assembly
- Ceramic lined enclosure contains flame to keep hands safe
- One knob controls the pilot and gas flow, another sets air flow for ideal combustion
- Burner lights easily with a striker (not included)
- No heat coils to burn out or circuitry to fail
- Includes one 600°F Temperature Crayon (above)
- Propane model includes gas regulator and hose assembly
- **Made to order - contact Goodson for current pricing and delivery time**

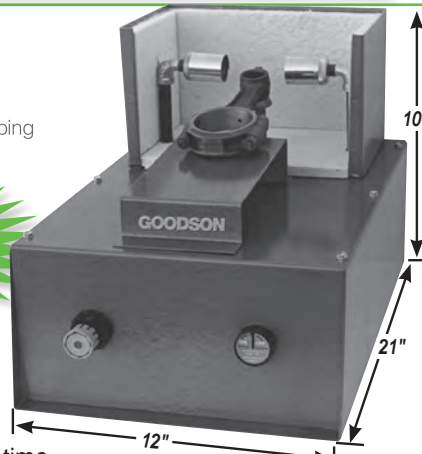

Description	Order No.
Rod Heater for Propane	RH-50
Rod Heater for Natural Gas	RH-50N



Band Ring Compressor Kits

- Install rings safely and easily • Hardened steel for durability
- Trigger ratchet mechanism for tight compressions

Description	Jobber	Order No.	Incl.
6 Pc. Band Ring Compressor Kit	\$ 64.99	GPS-98	▼
9 Pc. Band Ring Compressor Kit	129.99	GPS-99	▼
Compressing Pliers	24.99	GPS-98A	x x
Bands Range in. mm			
1.875" - 2.125"	47.63-53.98	\$16.49	GPS-98Q
2.125" - 2.375"	53.98-60.33	16.49	GPS-98R x
2.375" - 2.625"	60.33-66.68	16.49	GPS-98S x
2.625" - 2.875"	66.68-73.03	16.49	GPS-98T x
2.875" - 3.125"	73.03-79.38	16.49	GPS-98B x x
3.125" - 3.375"	79.38-85.73	16.49	GPS-98C x x
3.375" - 3.625"	85.76-92.08	16.49	GPS-98D x x
3.625" - 3.875"	92.08-98.43	16.49	GPS-98E x x
3.875" - 4.125"	98.43-104.78	16.49	GPS-98F x x
4.125" - 4.375"	104.78-111.13	16.49	GPS-98G x x
4.500" - 4.750"	114.30-120.65	16.49	GPS-98H
4.750" - 5.000"	120.65-127.00	16.49	GPS-98I
5.000" - 5.250"	127.00-133.35	16.49	GPS-98J
5.250" - 5.500"	133.35-139.70	16.49	GPS-98N

Rod Clamping Vice

- Align rods and caps perfectly
- Smooth jaws won't damage connecting rods like an ordinary vise
- Clamp rods firmly to align parting faces while torquing rod bolts
- Clamp in a vise or bolt to a workbench
- Order No. **RCV-20**
Jobber \$179.99

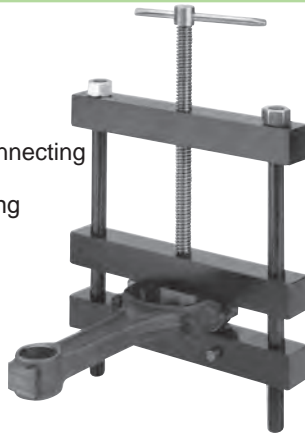

Rod Bolt Stretch Gauge

- Accurate to .001"
- Features a 1½" dial gauge
- Extra heavy-duty tension spring for repeatable accuracy
- For bolts from 1" to 2½" long
- See more information on rod bolt stretch on page 125

Description	Jobber	Order No.
Rod Bolt Stretch Gauge	\$86.99	RBSG-3
Optional Contact Point	12.99	ERBG-3T
Replacement Pointer	9.99	RBSG-P



Rod Bolt Boots

- Plastic boots protect crank journals & rod bolts during piston installation
- Save crank journals from rod bolt damage
- Don't risk your reputation for quality
- Reusable
- Set of 16
- Order No. **RBP-16**
Jobber \$8.99

Heavy-Duty Rod Bolt Installing Block

- Mount universal block in a vise to support rod while installing bolts
- Hardened aluminum won't slip
- If the top wears, you can restore it with a file or belt grinder
- Ream holes larger to accommodate oversize bolts
- Order No. **RB-50**
Jobber \$49.99



Connecting Rod not included



Piston Pin Installing Fixture

- Adjustable stops prevent over-centering rods
- Adjust the stop once and you're ready to assemble a full set of rods
- Base is pre-drilled to mount to a workbench
- Order No. **PIF-25**
Jobber \$109.99

Piston Ring Expander

- Remove and install most rings
- Tapered jaws
- ¾" to ¼" ring width
- Order No. **PRE-500**
Jobber \$15.99



Press Fit Lubricants

- A light coat eases press fit
- Ideal for valve guides, piston pins, cylinder sleeves, etc.
- Eliminates the scoring, gouging and galling of parts during press fitting



Description	Jobber 1+	Jobber 6+	Order No.
Goodson Aerosol 6 oz. (170 g)	\$13.99	\$12.59	PFL-200*
Sunnen® Aerosol 7 oz. (198 g)	21.27		B-200*
Sunnen® Brush Applicator 200 mL	28.93		B-200L*

*Hazardous Goods Fees Apply When Shipped By Air
Save 10% by buying 6 or more cans of PFL-200

Piston Installing Deadblow Hammer

- 1 piece design
- Specially formulated urethane compound is cut and split resistant
- Convex-faced, non-mushrooming material
- Offset head
- Ideal for fast, mar-free piston installation
- Weighs 1.7 lbs./ .77 kg
- Order No. **PK-200** Jobber \$64.99



Introduced in 2003!

made in
america

The Original Goodson Powered Ring Filers

- No more tedious filing and checking and filing and checking to get desired end gap; set it once and cut multiple rings
- Easy to read integral dial indicator and positive ring stop make repeatable precision quick and easy
- Fits 2½" to 5" / 63.5 to 127mm diameter rings
- Adjustable guide holds rings square to the cutting wheel
- Table pivots past cutting wheel
- No open ways to gather grinding dust that causes premature wear
- Handy knurled in-feed adjustment knob • High torque motor

Diamond Dresser is securely held in place by the ring clamping pin



Lighted
Rocker
Switch

Built-in deburring wheel eliminates the need to hand hone or deburr rings after filing

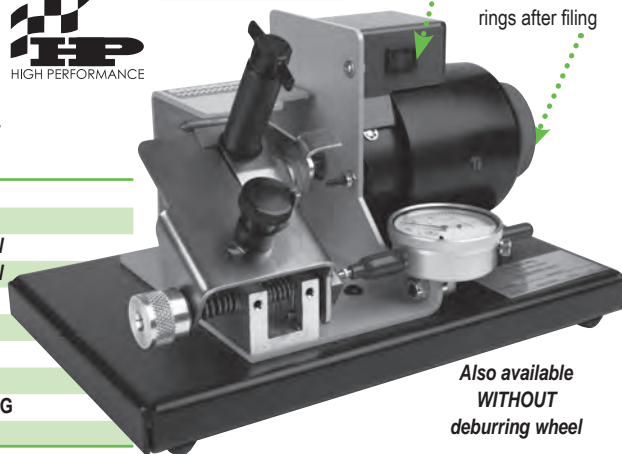

Also available
WITHOUT
deburring wheel

Description	Jobber	Order No.
Powered Ring Filer 110V / 60 cycle w/o Deburring Wheel	\$829.99	PRF-812
Powered Ring Filer with Deburring Wheel 110V / 60 cycle	929.99	PRF-812DW
Powered Ring Filer with Deburring Wheel 220V / 50 cycle	999.99	PRF-822DW
Replacement Deburring Wheel	43.99	PRF-DW
2½" Replacement Grinding Wheel (60 grit) for pre-2008 models	10.99	PRF-1001
3" Replacement Grinding Wheel (60 grit)	10.49	PRF-1002
Replacement Diamond Dresser	43.99	PRF-812D
Replacement Table Spring	26.99	PRF-SPRING
Sun-Dura® Canvas Machine Cover	32.99	GMC-PRF

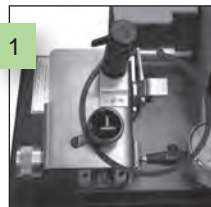

1
Stainless Steel Table

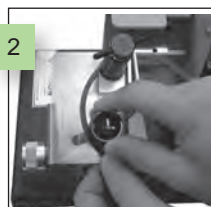

2
Eccentric adjusts quickly and easily

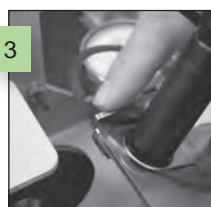

3
Positive ring stop

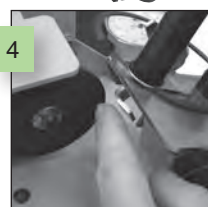

4
Table pivots past grinding wheel



GMC-PRF

Manual Ring Grinder

- Produce end gap rings squarely
- Heavy duty aluminum casting
- Precisely machined for long life
- Aluminum-Oxide wheel holds shape and produces clean precise cuts
- Includes 1 grinding wheel (replacements available)
- Wheel measures 2½" OD x ¾" ID x 1/8" thick

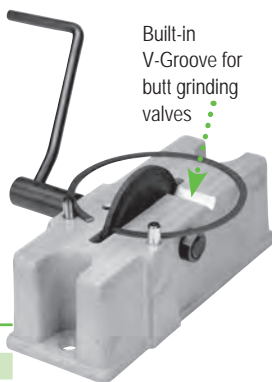

Built-in V-Groove for butt grinding valves



Manual Ring Grinder

- Universal design lets you grind almost any make, type or size of piston ring • Includes diamond abrasive wheel measuring 2" OD x ¼" ID x 1/16" Thick

Description	Jobber	Order No.
Piston Ring Grinder	\$107.99	PRF-250
Replacement Wheel	18.99	PRF-250W

Description	Jobber	Order No.
Universal Piston Ring Filer	\$77.99	PRF-500
Replacement Diamond Abrasive Wheel	52.99	PRF-870-DW

Fine Abrasive Stick

- Radiused for easier ring deburring after end gapping
- 4" L x ½" radius / 101.6mm x 12.7mm
- Works on all types of rings
- Works on ring ID radii
- Order No. **RS-103**
Jobber \$33.99



tech tips

from the techxperts™
Fine Abrasive
Sticks work great for deburring the ends of piston rings after filing, or any part that needs deburring. For a finer finish, soak the abrasive stick in Lapping Oil (LP-LO-4).

Stay Up-To-Date With Your Friends At Goodson!

We're On Social Media Are You?



Facebook

Twitter

Instagram

YouTube

Blog

CYLINDER HEAD
REBUILDING

CLEANING,
ASSEMBLY & SAFETY

SHORT BLOCK
REBUILDING

CRANKSHAFT/
FLYWHEEL GRINDING

MISCELLANEOUS
TOOLS & SUPPLIES

BRAKE SERVICE
TOOLING

MEASURING
TOOLS

V-TWIN & METRIC
HARD PARTS



"Technology has provided us with more efficient ways to give you, our customers, the quality of service you deserve! Our goal is to make ordering shop supplies faster & easier for you, whether you order by phone or through our website."

- Cheryl, Goodson IT/Order Fulfillment Manager - 27 years of service

CYLINDER HEAD
REBUILDING
CLEANING,
ASSEMBLY & SAFETY

Oil Gallery Plug Installer / Staker

- Set depth and lock plug in a single step
- Arbor nose aligns cup plug, then follows with two 180° staker lugs to set depth and lock oil gallery plug securely in place
- Use with Oil Gallery Plugs below
- Order No. **ST-SB**
Jobber \$56.99



SHORT BLOCK
REBUILDING

Steel Oil Gallery Plugs

- Replace lost or damaged originals
- 1/4" pipe plugs
- For use at the rear of Small Block Chevy oil galleries or other engines with similar size plugs
- 25 per box
- Order No. **OP-250**
Jobber \$11.99

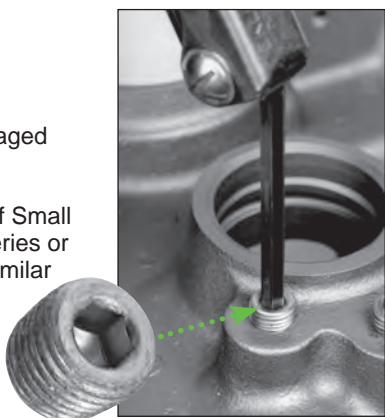

CRANKSHAFT/
FLYWHEEL GRINDING

MISCELLANEOUS
TOOLS & SUPPLIES

Oil Gallery Brushes

Steel Wire		Jobber 1+	Jobber 10+	Order No.	Incl.
3-pc. Kit		Size	Length	\$18.99	OGB-SK ▼
1/4"	x 3"	24"	8.99	\$8.09	OGB-1 x
3/8"	x 3"	24"	9.99	8.99	OGB-2 x
5/8"	x 3"	24"	10.99	9.89	OGB-3 x
Nylon Bristle		Size	Length	\$34.99	OGB-KIT ▼
3/8"	x 3"	34"	7.99	\$7.19	OGB-38 x
1/2"	x 2 1/2"	34"	7.99	7.19	OGB-42 x
5/8"	x 3"	34"	7.99	7.19	OGB-5 x
3/4"	x 3"	34"	8.99	7.09	OGB-7 x
3/4"	x 3"	40"	9.99	8.99	OGB-8 x

Buy 10 or more brushes (any combination), Save 10% off Jobber

BRAKE SERVICE
TOOLING

MEASURING
TOOLS



100% Natural Oil Gallery Beeswax

- Preheat the part to be removed, apply wax to its base, allow to cool and remove the part
- 100% natural beeswax
- Measures 1" x 3/4" x 3"
- Weighs 1 oz.
- Order No. **BWS-1** Jobber \$4.39

V-TWIN & METRIC
HARD PARTS

made in
america

Includes 1 Replaceable Blade

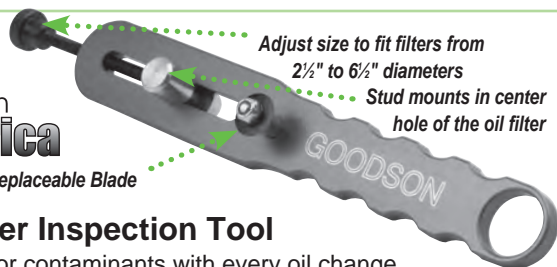

Oil Filter Inspection Tool

- Check for contaminants with every oil change
- Cut open the filter canister for inspection
- Fits 2 1/2" to 6 1/2" diameter filters
- Includes a single blade

Description	Jobber	Order No.
Oil Filter Inspection Tool	\$59.99	FIT-1-G
Replacement Cutter Blade	13.99	FIT-W

Oil Pump Pickup Tube Driver

- For all GM pumps
- Replace pickup tubes easily with a light mallet
- Driver grips the pickup tube flare
- Gives control for fast alignment and installation

Application	Tube OD	Jobber	Order No.
Small Block	5/8" / 15.9mm	\$34.99	TI-25
Big Block	3/4" / 19.1mm	34.99	TI-30

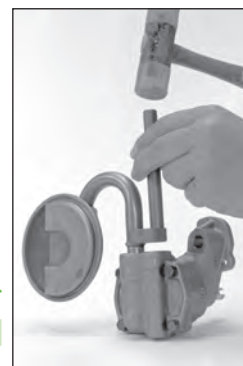

V-TWIN & METRIC
HARD PARTS

Oil Gallery Plug Removers

- Power plugs out with an impact wrench
- Threaded plug inside prevents bit from backing into the holder
- Hardened tool-steel holder with lifetime breakage guarantee (excludes bit)
- Tool-steel bit can be reground or replaced
- Set screw holds bit firmly in place
- 1/2" drive – fits your impact wrenches
- Do NOT use with a breaker bar or ratchet

Description	Size		Jobber	Order No.	Incl.
Plug Remover Kit	in	mm	\$189.99	PPS-KIT	▼
Replacement Tool	3/16"	4.76	43.99	PPS-187	x
Tool includes	1/4"	6.35	43.99	PPS-250	x
bit (except	3/32"	7.14	44.99	PPS-281*	x
PPS-281)	5/16"	7.94	43.99	PPS-312	x
	3/8"	9.53	43.99	PPS-375	x
Replacement Bits	3/16"	4.76	\$12.99	PPS-187B	
	1/4"	6.35	12.99	PPS-250B	
	5/16"	7.94	12.99	PPS-312B	
	3/8"	9.53	12.99	PPS-375B	

NOTE: *No bit is needed for PPS-281 (square socket).

... another satisfied customer

"Along with the slide hammer set, the lifter bore burnishing tool fixes tight lifter bores, even on assembled bottom ends quick and easy!! My last race motor build was going great until I noticed a few of my new lifters were real tight at the bottom of the bore.

This tool resized the bores fast and accurate even with the cam still in place. Due to the method of resizing, the entire block isn't contaminated with debris like a hone would do, and saves time and money."

- Grant Farmer, Grand Island, NY, Goodson Customer since 2018

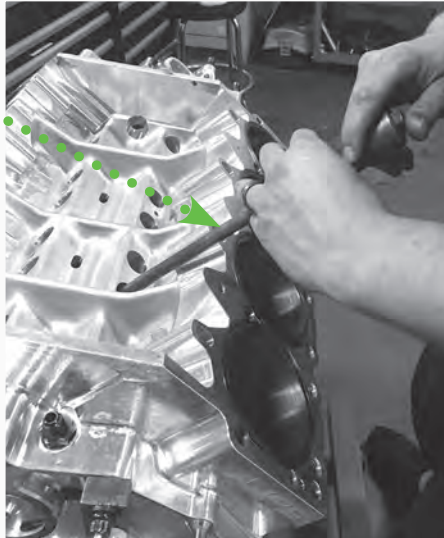

Photo courtesy Tim Wilkerson Racing

Lifter Bore Burnishing Tools

- Eliminate burrs caused by shot blasting
- Drive the burnishing tool into the bore with a soft hammer then slide-hammer it back out
- 60 Rc burnishing balls deburr and correct out of round lifter bores quickly and easily
- Won't oversize the bore
- High Performance Sets include a FREE storage case



Lifter Bore Burnishing Balls

Description	Jobber	Order No.	Includes
1.0625" High Performance Set	\$184.99	LBB-625-KIT	
1.0000" High Performance Set	184.99	LBB-1000-KIT	
Standard Burnishing Tool Set	184.99	LBB-1500	
14" Slide Shaft	17.99	GAO-1	x
15" Slide Shaft	21.99	LBB-1	x x
Slide Hammer	24.99	GAO-2	x x x
Lifter Bore Burnishing Balls			
0.8450" dia. (General Motors)	41.99	LBB-GM1	x
0.8760" dia. (Ford)	41.99	LBB-FO1	x
0.9060" dia. (Chrysler)	41.99	LBB-CR1	x
1.0000" dia.	61.99	LBB-1.000	x
1.0010" dia.	61.99	LBB-1.001	x
1.0625" dia.	61.99	LBB-1.0625	x
1.0635" dia.	61.99	LBB-1.0635	x
Jam Nut	9.79	LBB-NUT	x x x
Lifter Bore Brushes.			
7/8" (.875") dia.	8.99	LBB-875	
1" (1.00") dia.	9.99	LBB-100	x
1 1/8" (1.125") dia.	9.49	LBB-1125	x



HIGH PERFORMANCE

Retainer for 6" Mandrel

Honall Head

6" Mandrel

Wedge for 6" Mandrel

Adaptor

Retainer for 6.75" Mandrel

Wedge for 6.75" Mandrel

6.75" Extended Mandrel

Roughing or Finishing Stone

Truing Sleeve



Sunnen® Lifter Bore Hones

- Restore bore size and finish after shot blasting
- Install oversize lifters for high-performance
- Stones work in cast iron bores or ones sleeved with brass or steel
- Wide stones contact a large area giving better stability for hand honing
- Cross oil ports without catching
- Wedge-type adjustment is a simple, positive way to expand or contract the stone to the precise size needed
- Use a 3/8"(9.5mm) or 1/2"(12.7mm) hand-held electric or air drill at approx. 200 RPM
- Use with honing oil
- **All parts MUST be ordered separately to make a complete unit**

tech tips
from the techxperts™

NOTE: Wedges may come with a tab that must be removed **BEFORE** using them with the P-180 Head

Description	Jobber	Order No
Honall Head	\$475.69	P-180
Adaptor	92.99	PAK20-A
Roughing Stone (280 Grit) 12/box	111.22	Y20-J67
Finishing Stone (400 Grit) 12/box	111.22	Y20-J87
Standard Lifter Bore Tooling (6" Reach)		
Mandrel .838" - .869" Range	\$447.45	AA220838BH6LH
.869" - .900" Range	447.45	AA220869BH6LH
Wedge	89.89	Y20-W-6LH
Retainer	54.74	LN-3688A-6LH
Truing Sleeve .838" - .869" Range	28.75	S-838
.869" - .900" Range	28.75	S-869
Extended Reach Lifter Bore Tooling (6 1/2" Reach)		
Mandrel .838" - .869" Range	\$478.78	AA220838675LH
.869" - .900" Range	462.59	AA220869675LH
Wedge	89.89	Y20-W-675LH
Retainer	54.74	LN-3688A675LH
Truing Sleeve .838" - .869" Range	28.75	S-838
.869" - .900" Range	28.75	S-869

Goodson is authorized to ship Sunnen products within the Western Hemisphere



Rod Honing Oil

- Includes additives for high pressure cutting
- Keeps stones clean and free-cutting during rod reconditioning, pin fitting and other honing applications
- Will mix with other honing oils (including Sunnen®)

Size	Jobber	Order No.
1 Gal. (3.78L)	\$ 38.99	RHO-10
5 Gal. (18.9L)	189.99	RHO-50

CYLINDER HEAD REBUILDING
CLEANING, ASSEMBLY & SAFETY
SHORT BLOCK REBUILDING
FLYWHEEL GRINDING
CRANKSHAFT/ TOOLS & SUPPLIES
MISCELLANEOUS
BRAKE SERVICE TOOLING
MEASURING TOOLS
V-TWIN & METRIC HARD PARTS

... another satisfied customer

"It's a pleasant surprise to deal with a company that obviously cares about customer service. Your website was easy to use and order feedback assuring. Keep up the good work."
 — Norm Cameron, St. Petersburg, FL, Goodson customer since 2017

CYLINDER HEAD REBUILDING

CLEANING, ASSEMBLY SAFETY

SHORT BLOCK REBUILDING

CRANKSHAFT/ FLYWHEEL GRINDING

MISCELLANEOUS TOOLS & SUPPLIES

BRAKE SERVICE TOOLING

MEASURING TOOLS

V-TWIN & METRIC HARD PARTS



Universal Cam Bearing Tool

- Remove and install hundreds of sizes of cam bearings with just four mandrels!
- Expanding Mandrels cover a 1.370"-2.250" range
- Adjusts instantly to under-size bearings so you can remove and install them from virtually any block
- Approximately 1/4" range for each size segment
- Interchangeable with Dura-Bond

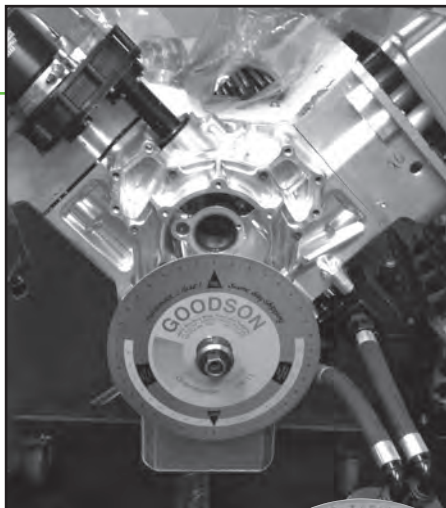

Degree Wheel

- Check cam timing, duration and overlap
- Degree wheel measures 11" / 279.4mm dia. with 1 1/8" / 47.6mm hole • Complete kit includes the Degree Wheel, a 3/4" ID mounting hub for mounting on cranks using 7/16" to 3/4" fasteners, a 1/2" hub and necessary fasteners • Use hubs or turning tool to mount the wheel.
- Use with 1/2" drive ratchet

Wheel / Adaptors	Jobber	Order No.	Incl.
Automotive Degreeing Kit	\$48.99	DW-KIT-2	▼
Degree Wheel	32.99	DW-11	x

Description	Jobber	Order No.	Incl.
Universal Cam Bearing Tool	\$679.99	CBT-300	▼
Replacement Segment with Sleeve			
Max Dia.	1.370"	\$62.99	CBT-5M x
	1.682"	63.99	CBT-6M x
	1.875"	67.99	CBT-7M x
	2.250"	74.99	CBT-8M x
Replacement Backing Plate			
Max Dia.	1.375"	\$16.99	CBT-5W x
	1.682"	18.99	CBT-6W x
	1.885"	19.99	CBT-7W x
	2.250"	20.99	CBT-8W x
Replacement Neoprene Sleeve			
Max Dia.	1.370"	\$ 8.99	CBT-5NS
	1.682"	10.99	CBT-6NS
	1.875"	10.99	CBT-7NS
	2.250"	12.99	CBT-8NS
Drivers			
Length	5" (pictured above)	\$ 59.99	CBT-1B x
	24"	119.99	CBT-2B
	36" (pictured above)	154.99	CBT-3B x
	48"	159.99	CBT-4B
Miscellaneous Replacement Parts			
	1.200" Expander with stud	\$63.99	CBT-3E x
	1 1/2" Expander with stud	59.99	CBT-4E
	1/2"x13 Stud	13.99	CBT-1S x
	3" Guide Cone	35.99	CBT-1C x
	Replacement Threaded Impact Cap	49.99	CBT-300-CAP x
	Steel Storage Rack	89.99	CBT-300-WR x
INTERCHANGEABLE WITH DURA-BOND			

This is ... another one of those satisfied customer **customer**
MUST have tools for the shop and trailer. We have needed our Goodson Degree wheel at the track a few times and in a few minutes we are done and ready to go! Thanks again great equipment.
 — Dean Dubbin, DMP Awnings (NHRA Top Alcohol Dragster), Goodson customer since 2010

Bearing Scraper

- Eliminate bearing high spots after installation to ensure correct oil clearance
- Solid hardwood handle
- 4" / 101.6mm blade with 3 cutting edges
- German steel blade
- Order No. **BS-30**
 Jobber \$43.99



Lifting Sling

- Lift up to 1800 lbs. safely and easily
- 1" x 36" looped nylon webbing sling
- Do NOT use with caustics or temperatures exceeding 190°F
- Order No. **LS-3** Jobber \$10.99



Whether you're regrinding cores for stock applications or custom grinding for diesel and high performance, you can count on Goodson Cam Grinding Wheels to deliver an excellent finish

Goodson abrasives are second to none. We work with our manufacturers to get you the most ideal grain that's bonded to be free-cutting, yet still shed before loading up. Our Premium wheels are ideal for steel high performance camshafts of 55 to 65 Rc and for Stellite overlays. Goodson finishes all Camshaft Grinding Wheels to your specifications in-house for faster turn-around and delivery. Choose from the sizes below or custom order your cam wheel today!



CYLINDER HEAD
REBUILDING

CLEANING,
ASSEMBLY & SAFETY

SHORT BLOCK
REBUILDING

CRANKSHAFT/
FLYWHEEL GRINDING

MISCELLANEOUS
TOOLS & SUPPLIES

BRAKE SERVICE
TOOLING

MEASURING
TOOLS

V-TWIN & METRIC
HARD PARTS

Cam Grinding Wheels - WAA54-L5V1 - 54 Grit

Diameter	Width	Arbor	Jobber	Order No.
18"	3/4"	19mm 6"	152mm \$229.99	E341420
457mm	7/8"	22mm 6"	152mm 239.99	E335351
	1"	25mm 6"	152mm 249.99	E335352
	1 1/8"	29mm 6"	152mm 279.99	E335353
	1 1/4"	32mm 6"	152mm 279.99	E335354

Cam Grinding Wheels - 43A602-K8-V1 - 60 Grit

Diameter	Width	Arbor	Jobber	Order No.
18"	3/4"	19mm 6"	152mm \$229.99	E342030
457mm	7/8"	22mm 6"	152mm 234.99	E339945
	1"	25mm 6"	152mm 249.99	E342031
	1 1/4"	32mm 6"	152mm 279.99	E348558

Cam Grinding Wheels - 7BL801 - 80 Grit

Diameter	Width	Arbor	Jobber	Order No.
18"	3/4"	19mm 6"	152mm \$369.99	E416880
457mm	7/8"	22mm 6"	152mm 369.99	E427392

Due to the manufacturing process, actual colors may vary

Cam Grinding Wheels - WAA100 - 100 Grit

Diameter	Width	Arbor	Jobber	Order No.
18"	3/4"	19mm 6"	152mm \$269.99	E379225
457mm	7/8"	22mm 6"	152mm 274.99	E397667
	1 1/4"	32mm 6"	152mm 299.99	E416183

Standard Goodson Cam Grinding Wheels - 100 Grit

Diameter	Width	Arbor	Jobber	Order No.
18"	3/4"	19mm 6"	152mm \$244.99	GCC 18 x 0.750 x 6
457mm	7/8"	22mm 6"	152mm 244.99	GCC 18 x 0.875 x 6
	1"	25mm 6"	152mm 249.99	GCC 18 x 1.000 x 6
	1 1/4"	32mm 6"	152mm 277.99	GCC 18 x 1.250 x 6

Due to the manufacturing process, actual colors may vary

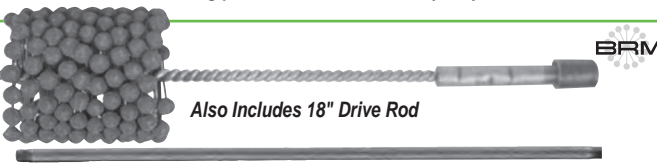

Also Includes 18" Drive Rod

180 Grit Cam Bearing Flex-Hones®

- Silicon-Carbide globules laminated to high density nylon
- Includes 18" drive rod

Inch	mm	OAL	Jobber 1+	Jobber 3+	Order No.
1 3/4"	45	17 1/2"	\$57.99	\$52.19	CBF-175
2"	51	17 1/2"	59.99	53.99	CBF-200
2 1/4"	57	17 1/2"	60.99	54.99	CBF-225
2 1/2"	64	17 1/2"	62.99	56.99	CBF-250
2 3/4"	70	17 1/2"	63.99	57.99	CBF-275

Order 3 or more (mix or match) to Save 10% off Jobber

Bore Washing Brushes

- Clean tunnel housing bores and full-annular grooved area
- Heavy, hand-driven shank

Bore Washing Brushes

Dia.	Length	Jobber 1+	Jobber 10+	Order No.
2"	36"	\$21.99	\$19.79	CBB-200
2 1/4"	36"	22.99	20.69	CBB-225
2 1/2"	36"	23.99	21.59	CBB-250
2 3/4"	18 1/2"	21.99	19.79	CWB-27W
3 1/2"	18 1/2"	21.99	19.79	CWB-35
4"	18 1/2"	23.99	21.59	CWB-40
4 1/2"	18 1/2"	25.99	23.39	CWB-45
5"	18 1/2"	37.99	34.19	CWB-50

Order 10 or more (mix or match) to Save 10% off Jobber

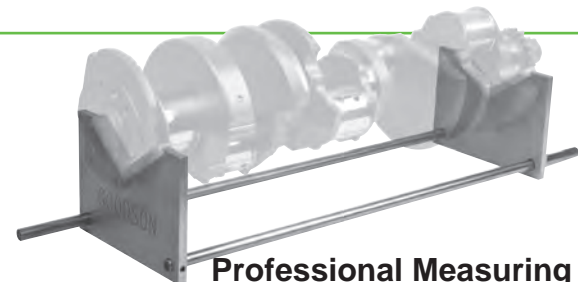

Professional Measuring & Inspection Stand For Cranks & Cams

- Length adjusts up to 23" to fit journal spacing
- Rotate work to view or measure
- Solid aluminum frame with self-lubricating, corrosion and chemical-resistant wear surfaces
- Order No. **PMIS-30** Jobber \$134.99

Cam & Crank Grinding Coolant

- Semi synthetic
- Non-nitrite
- High-lubricity
- Dilute 20 parts water to 1 part coolant

Size	Jobber	Order No.
1 gallon (3.78L)	\$ 36.99	CGC-10
5 gallons (18.93L)	159.99	CGC-50



full service
...fast



"The Mach-B division of Goodson offers many services such as ANSI compliant speed testing, balance testing, grinding wheel shaping, resizing and more. Find out more at Mach-B.com."

- Jon, Goodson Production Manager, 40 years of service

Goodson crankwheels are made-to-order in-house

Other sources stock finished wheels, which makes it virtually impossible to stock a full range of sizes. If they don't have what you need, they may charge more and delay your order for weeks. That's why Goodson makes every wheel to order. We always have the right wheel because we take a Type 1 straight wheel, size it, shape it, speed test it and ship it.

For future reference write down your

Crank Wheel Number (s)

Select the shape



Hub

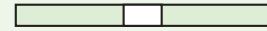

Straight

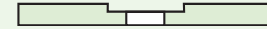

Recessed 1 Side

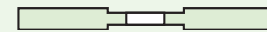

Recessed 2 Sides

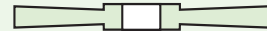

Tapered

Select your wheel grade:

WAA



Superior Grade - 54 grit
Excellent dimensional accuracy, corner radii and surface finish. For multiple applications including weld grinding. Ideal for grinding everything from cast iron to steel. Finishing and roughing wheel. Aluminum-oxide abrasive for light to medium stock removal.

CSS ULTRA

Premium Grade
This new abrasive formulation from Tyrolit/Radic combines high-quality components and an innovative bonding technology to produce a long-lived, cool grinding abrasive wheel. White and sintered aluminum-oxide. Stock removal rates can be increased without sacrificing quality.

GCH



Superior Grade - 54 grit
Better form holding ability, cuts cooler and needs less dressing. Use on crank journals with Rockwell hardness of 35 Rc or less. Use on crankshafts of cast or forged steel, Nodular iron. Ideal for large radii, thrust and plunge grinding. Great for high-performance.

GCD

Premium Grade - 60 grit
For harder materials. Good form holding ability; cuts cooler and needs less dressing. Grains yield faster, cooler grinding. Use on journals with Rockwell hardness of 35 Rc or more. Ideal for diesel, high-performance, industrial and billet steel.

Increase coolant flow with Crankwheel Slotting

Slotting facilitates the flow of coolant to the thrust and radius areas of the crankshaft to prevent journal burning. Highly recommended for high performance and diesel crankshafts. Don't waste time waiting on other suppliers who outsource their crankwheels for slotting - Goodson has a shop full of equipment, so we slot wheels in house!
Order No. **SLOTTING Jobber \$75.00**

How to order:

If you have any questions, please call 1-800-533-8010

Grade	Diameter	Face Width	Arbor Size	Machine	Shape
WAA - Superior	Diameters are available from	Most sizes from	Arbor size of your	Identify the make	Specify the shape
GCD - Premium	18" to 36" in most	3/4" to 2 5/8" (custom	grinder. Any arbor	and model of your	for your grinder.
GCH - Superior	grades.	widths are no extra	hole from 3" to 12".	grinder.	
CSS-ULTRA		charge).			

Crankshaft Grinding Wheels



		WAA		CSS		GCH		GCD	
Dia.	Face Width	Jobber	Jobber	Jobber	Jobber	Jobber	Jobber	Jobber	Jobber
Fits Storm Vulcan 14, 15									
18"	3/4"-1"	\$249.99	call	\$269.99	call				
3" Arbor	1 1/64"-1 1/4"	259.99	call	279.99	call				
	1 17/64"-1 1/2"	279.99	call	419.99	call				
	1 33/64"-1 3/4"	289.99	call	459.99	call				
	1 49/64"-2"	299.99	call	479.99	call				
Fits Storm Vulcan 15, 15 Special, 1550, 1648									
20"	3/4"-1"	\$259.99	call	\$269.99	call				
3" Arbor	1 1/64"-1 1/4"	269.99	call	299.99	call				
	1 17/64"-1 1/2"	279.99	call	419.99	call				
	1 33/64"-1 3/4"	289.99	call	459.99	call				
	1 49/64"-2"	299.99	call	479.99	call				
Fits Kwik-Way / Lempco									
20"	3/4"-1"	call	call	call	call				
3 3/4" Arbor	1 1/64"-1 1/4"	call	call	call	call				
	1 17/64"-1 1/2"	call	call	call	call				
	1 33/64"-1 3/4"	call	call	call	call				
	1 49/64"-2"	call	call	call	call				
Fits Kwik-Way / Lempco 539 & Storm Vulcan 15A (early)									
22"	3/4"-1"	\$349.99	call	call	call				
5" Arbor	1 1/64"-1 1/4"	369.99	call	call	call				
	1 17/64"-1 1/2"	379.99	call	call	call				
	1 33/64"-1 3/4"	559.99	call	call	call				
	1 49/64"-2"	559.99	call	call	call				
Fits Peterson Berco 180									
22"	3/4"-1"	call	call	call	call				
8" Arbor	1 1/64"-1 1/4"	call	call	call	call				
	1 17/64"-1 1/2"	call	call	call	call				
	1 33/64"-1 3/4"	call	call	call	call				
	1 49/64"-2"	call	call	call	call				
Fits Storm Vulcan 15A (late), 15A Special; RMC/Robbi REX-1200									
Fits Kwik-Way / Lempco KGA and NKG Series									
24"	3/4"-1"	\$349.99	call	\$604.99	\$619.99				
5" Arbor	1 1/64"-1 1/4"	369.99	call	709.99	729.99				
	1 17/64"-1 1/2"	399.99	call	719.99	779.99				
	1 33/64"-1 3/4"	529.99	call	729.99	819.99				
	1 49/64"-2"	549.99	call	759.99	839.99				
Van Norman 438, 448, 460, 465;									
Winona Van Norman/Zanrosso CG-210 (early); Storm Vulcan Sclendum 200									
24"	3/4"-1"	\$439.99	call	549.99	\$649.99				
8" Arbor	1 1/64"-1 1/4"	529.99	call	659.99	729.99				
	1 17/64"-1 1/2"	599.99	call	769.99	799.99				
	1 33/64"-1 3/4"	629.99	call	859.99	899.99				
	1 49/64"-2"	639.99	call	899.99	919.99				
Storm Vulcan 15C									
25"	3/4"-1"	\$429.99	call	\$539.99	\$689.99				
5" Arbor	1 1/64"-1 1/4"	449.99	call	579.99	749.99				
	1 17/64"-1 1/2"	549.99	call	599.99	819.99				
	1 33/64"-1 3/4"	569.99	call	619.99	859.99				
	1 49/64"-2"	589.99	call	629.99	879.99				
AMC K1100; Peterson Berco 180, 225; Sclendum 200, 230; Van Norman 438, 448, 460, 465, 475, 476; Winona Van Norman CG-210 (late), CG-840									
26"	3/4"-1"	\$449.99	\$579.99	\$619.99	\$649.99				
8" Arbor	1 1/64"-1 1/4"	479.99	634.99	679.99	729.99				
	1 17/64"-1 1/2"	549.99	659.99	739.99	759.99				
	1 33/64"-1 3/4"	599.99	744.99	859.99	889.99				
	1 49/64"-2"	659.99	754.99	899.99	929.99				
	2 1/64"-2 1/4"	call	859.99	999.99	1029.99				

		WAA		CSS		GCH		GCD	
Dia.	Face Width	Jobber	Jobber	Jobber	Jobber	Jobber	Jobber	Jobber	Jobber
Schou 1500/270, 1600, 260									
27 1/2"	3/4"-1"	call	call	call	call				
8 5/8" Arbor	1 1/64"-1 1/4"	call	call	call	call				
	1 17/64"-1 1/2"	call	call	call	call				
	1 33/64"-1 3/4"	call	call	call	call				
	1 49/64"-2"	call	call	call	call				
	2 1/64"-2 1/4"	call	call	call	call				
Peterson Berco 260; SV Sclendum 230, 270/280; Zanrosso Mito 250; Van Norman 400, 438, 454, 475, 476, 666; RMC/Robbi REX-1500									
28"	3/4"-1"	\$549.99	\$634.99	\$629.99	\$649.99				
8" Arbor	1 1/64"-1 1/4"	619.99	709.99	679.99	719.99				
	1 17/64"-1 1/2"	629.99	744.99	829.99	859.99				
	1 33/64"-1 3/4"	659.99	834.99	879.99	909.99				
	1 49/64"-2"	679.99	849.99	919.99	939.99				
	2 1/64"-2 1/4"	719.99	974.99	1014.99	1049.99				
	2 17/64"-2 5/8"	call	call	call	1069.99				
Seest MC62									
30"	3/4"-1"	call	call	call	call				
6" Arbor	1 1/64"-1 1/4"	call	call	call	call				
	1 33/64"-1 3/4"	call	call	call	call				
	1 49/64"-2"	call	call	call	call				
Zanrosso Mito 280; Storm Vulcan Sclendum 270/280; RMC / Robbi REX-1800, REX 2200L									
30"	3/4"-1"	\$519.99	call	\$969.99	\$979.99				
8" Arbor	1 1/64"-1 1/4"	529.99	call	1029.99	1089.99				
	1 17/64"-1 1/2"	579.99	call	1139.99	1199.99				
	1 33/64"-1 3/4"	649.99	call	1179.99	1329.99				
	1 49/64"-2"	769.99	call	1299.99	1339.99				
	2 1/64"-2 1/4"	call	call	call	1349.99				
	2 17/64"-2 5/8"	call	call	call	1359.99				
AMC 1400, K1500, K1800; Van Norman 467, 477; Zanrosso									
32"	3/4"-1"	\$649.99	call	\$969.99	\$979.99				
8" Arbor	1 1/64"-1 1/4"	679.99	call	1029.99	1089.99				
	1 17/64"-1 1/2"	719.99	call	1139.99	1199.99				
	1 33/64"-1 3/4"	769.99	call	1179.99	1329.99				
	1 49/64"-2"	829.99	call	1299.99	1339.99				
	2 1/64"-2 1/4"	call	call	call	1349.99				
	2 17/64"-2 5/8"	call	call	call	1359.99				
Peterson Berco 280, 300; RMC Robbi REX-1800RM; REX-2200, REX-2200RM, REX-2700RM, REX-3100RM									
32"	3/4"-1"	call	call	call	call				
12" Arbor	1 1/64"-1 1/4"	call	call	call	call				
	1 17/64"-1 1/2"	call	call	call	call				
	1 33/64"-1 3/4"	call	call	call	call				
	1 49/64"-2"	call	call	call	call				
	2 1/64"-2 1/4"	call	call	call	call				
2 17/64"-2 5/8"	call	call	call	call					
Peterson Berco 300, 350; Storm Vulcan Sclendum 250; RMC / Robbi REX-2200M, 2700M, 3100M; Winona Van Norman 111									
36"	3/4"-1"	\$739.99	call	call	\$1119.99				
12" Arbor	1 1/64"-1 1/4"	739.99	call	call	1179.99				
	1 17/64"-1 1/2"	809.99	call	call	1339.99				
	1 33/64"-1 3/4"	809.99	call	call	1399.99				
	1 49/64"-2"	869.99	call	call	1489.99				
	2 1/64"-2 1/4"	call	call	call	1539.99				
2 17/64"-2 5/8"	call	call	call	call					

NOTE: All wheel widths are delivered up to .015" oversized to allow for side dressing when mounting the wheel

CYLINDER HEAD REBUILDING
CLEANING, ASSEMBLY & SAFETY
SHORT BLOCK REBUILDING
CRANKSHAFT/FLYWHEEL GRINDING
MISCELLANEOUS TOOLS & SUPPLIES
BRAKE SERVICE TOOLING
MEASURING TOOLS
V-TWIN & METRIC HARD PARTS



"We've continually expanding our production department to provide more flexibility in grinding wheel shapes and profiles. Give us a call when you need something special."

- James, Goodson Production, 2 years of service

CYLINDER HEAD
REBUILDING

CLEANING,
ASSEMBLY & SAFETY



Crankshaft Journal Radius Gauge

- 16 radii ... 1/32" to 17/64"
- Measure radii of reground journals quickly
- Blades are clearly marked in 1/64" increments
- Use in holder or remove to use blades separately
- Order No. **RG-16** Jobber \$48.99

SHORT BLOCK
REBUILDING

Hardness Tester

- Calculate Rockwell Hardness quickly and accurately
- Range: 15 to 65 Rockwell on C-Scale
- Features a steel ball of precise weight and shape which is dropped from an exact height to yield an accurate Rc reading
- Check overheated or repaired crankshaft journals to confirm correct hardness
- Also use on flywheels
- Weighs just 4 oz. • 9 1/4" long
- Includes case & instructions
- Order No. **HT-45RC** Jobber \$269.99



CRANKSHAFT/
FLYWHEEL GRINDING

Hand-Held Dressing Sticks

- Keep your crankshaft grinding wheels cutting clean

GG-112

DS-NOR



Hard Silicon-Carbide

- 1" x 1" x 6"
- Use to deglaze wheel side
- Removes material with light pressure
- Order No. **GG-112** Jobber \$21.99

Dense Granular Norbide

- 3/16" x 1/2" x 3"
- Long lasting
- For fine tuning radius and side relieving wheels
- Order No. **DS-NOR** Jobber \$74.99

Starrett

Universal 12"L Quick-Set Crankshaft Grinder Dial Indicator

- 3/8" diameter shaft • 12" long
- .125" travel, .050" per revolution
- Rotating, lockable bezel graduated in .001" from -.025" to + .025"
- Order No. **MDI-12** Jobber \$449.99



Goodson exclusive

More Dial Indicators on page 129

MISCELLANEOUS
TOOLS & SUPPLIES

Mach-B Grinding Wheel Shaping & Resizing



From routine grinding wheel shaping and sizing to emergency work, **Mach-B Can Do That!**

Mach-B Grinding Wheel Shaping & Resizing specializes in:

- Custom Grinding Wheel Shaping
- Custom Grinding Wheel Sizing
- Reducing Outside Diameters
- Increasing Inside Diameters
- ANSI Compliant Speed Testing
- Static Balance Testing
- Standard and Custom Profiles
- Grinding Wheel Slotting



Turn to Mach-B and Goodson for Fast Turnaround. Visit www.mach-b.com for more information.



Goodson has several videos available related to Camshaft & Crankshaft Grinding. To access them on our website, simply scan the appropriate code with your smart phone or other smart device.

Crankshaft Grinding Wheel Selection



Grinding Wheel Slotting



MEASURING
TOOLS

V-TWIN & METRIC
HARD PARTS

Dampener Installer

- Install harmonic dampeners without thrust bearing damage
- Screw tool into hole in the crankshaft end
- Use the nut and thrust bearing to draw the harmonic dampener onto the crankshaft snout
- Fits $\frac{7}{16}$ " x 20" and $\frac{1}{2}$ " x 20" holes • 3 piece set
- Order No. **DIT-2** Jobber \$69.99



Eliptibur Tool

- Fastest, safest way to chamfer crank oil holes
- Simplify deburring and chamfering of angularly drilled holes on cylindrical surfaces
- Easily produces a chamfer of relative uniformity and depth
- Self-centering, spring loaded pilot
- Includes one replaceable blade
- For 30Rc or softer crankshafts

Description	Jobber	Order No.
Eliptibur Tool (1 blade included)	\$289.99	EBT-15
Replacement Blade	45.99	EBT-15B
Replacement Pilot	86.99	EBT-15N



Create a relief in the block for rod #2 at the pan rail area using your normal process.



Place the arbor in main saddles 1 & 2, keeping the flange nearest to the pointer against #2.



Rotate the arbor and adjust the pointer until the tapered end passes freely through the relief with a minimum of clearance.



Lock the pointer in position with the set screw and check the clearance.



Once satisfied, scribe a line on the pointer opposite the set screw.

Stroker Mimic™

- Lightweight and easy to use
- Eliminates the need to repeatedly install and remove the crankshaft, pistons, rod assembly and the necessary bearings when clearancing a block for a stroker crank
- Once the Stroker Mimic™ has been set to a particular crank, rod and piston combination, the tool can be marked or measured for future reference
- Order No. **SM-350** Jobber \$109.99



Must have when building a Stroker Engine!



Reluctor Ring Installation Tool



All steel construction features 2 indexing dowels to properly align the reluctor ring when installing it on the crankshaft. Designed to fit Generation III (LS1, LS6) and Generation IV (LS2, LS3, LS7) engines. Aligns GM sensor rings (12559353, 12586768). **US Patent No. 7,716,827.**

Goodson exclusive

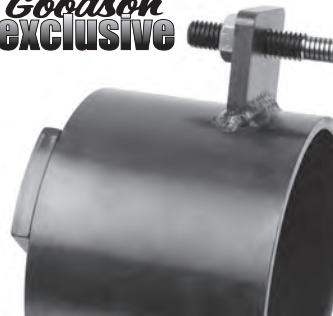

The 8mm indexing dowel is attached to the fixture by an exterior tang. It can be adjusted for depth to accommodate a variety of popular flange widths. This dowel fits into the only 8mm hole on the reluctor wheel.



The internal indexing dowel pin is designed to fit into the dowel pin hole on the crankshaft. It is adjustable to fit different depths. The combination of dowel pins gives very precise alignment of the reluctor wheel and crankshaft.

Description	Jobber	Order No.
Reluctor Ring Installation Tool	\$259.99	RRJ-350
Temperature Indicating Crayon (450° F/232°C)	23.99	TIC-450

tech tips
from the techperfs™

Heat reluctor ring to 450°F (232°C) then slide it onto the casting. Be sure to deburr all components before beginning assembly. Any sharp edges will cause the reluctor ring to catch on the casting, making assembly impossible.

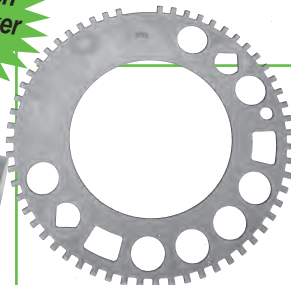

GM Steel 58 Tooth Reluctor Ring

- Single Piece Steel
- Fits LS2, LS3 & LS7
- Order No. **RR-58T** Jobber \$49.99



Callies Billet Steel Reluctor Ring

- For LS1 & LS6 Engines
- Single Piece
- Order No. **RR-24T** Jobber \$134.99



CYLINDER HEAD REBUILDING
CLEANING, ASSEMBLY & SAFETY
SHORT BLOCK REBUILDING
CRANKSHAFT/FLYWHEEL GRINDING
MISCELLANEOUS TOOLS & SUPPLIES
BRAKE SERVICE TOOLING
MEASURING TOOLS
V-TWIN & METRIC HARD PARTS



"If you're not sure what to order or if you have any questions, give us a call! We're here weekdays from 8am to 5pm Central Time, to serve you. We can help you get the most from our products and your equipment."

- Chris, Goodson ASE-Certified Master Machinist, 35 years of service

CYLINDER HEAD REBUILDING
CLEANING, ASSEMBLY & SAFETY
SHORT BLOCK REBUILDING
CRANKSHAFT/FLYWHEEL GRINDING
MISCELLANEOUS TOOLS & SUPPLIES
BRAKE SERVICE TOOLING
MEASURING TOOLS
V-TWIN & METRIC HARD PARTS

Stroke Checker

- Accurately measure strokes up to 6"
- Works with any precision caliper to accurately measure crankshaft strokes
- Measures strokes up to 6" with an accuracy of .001"
- Rigid, hard-anodized aluminum frame is fully adjustable
- Fits almost any crankshaft
- Order No. **CSG-1** Jobber \$199.99

See page 129 for our selection of calipers



Heavy Duty Steel Stamps

- For hard materials
- Order in sets

Number Sets			
Figure	Shank	Jobber	Order No.
1/8"	5/16"	\$49.99	SFH-1/8
3/16"	3/8"	54.99	SFH-3/16

Special and custom orders are available, call 1-800-533-8010

Crankshaft Grinder Steady Rest Shoes for Peterson-Berco

- 5/16" thick
- Use same shoe for upper and lower replacement
- Order No. **RBE-200** Jobber \$27.99

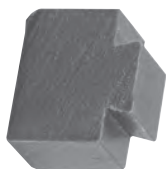

Plastigage

- Accurately measure bearing clearance
- Color coded by size
- Put a piece on rod or main bearing and torque the cap
- Remove and inspect – width of crushed Plastigage shows clearance
- Use at the workbench or in the vehicle
- 10 per pack

Clearance Range	Jobber	Order No.
.001" to .003" (.025 to .076mm)	\$23.99	PG-GREEN
.002" to .006" (.051 to .152mm)	23.99	PG-RED
.004" to .009" (.102 to .229mm)	23.99	PG-BLUE
10pk. Assortment : 5 Green, 3 Red, 2 Blue	23.99	PG-10PK



Crankshaft Straightening Peening Tool

- Designed for narrow journals on some new-style V6 crankshafts
- Peen crankshafts in the radius area of damaged journals to straighten
- Long-shank
- Offset-radius face
- 10" long • 0.0625" radius
- 0.125" diameter

Description	Jobber	Order No.
Peening Tool	\$53.99	CPT-062
Safety Glasses	6.49	PGL-21



tech tips
from the techexperts™
**Stay Safe In
The Workplace!**
Always wear protective gear.

Sanding, Grinding, Polishing Belts Made to Order In-House

To provide you better service and save you money, Goodson bought an abrasive converting company in 2017. Since then, we've added equipment and personnel and we're cranking out abrasive belts for a wide range of industries. **Abrasive Industrial Supplies** is operated as a division of Goodson and our feet are still firmly placed in the automotive market.

Almost every abrasive belt shown in the Goodson catalog is manufactured by **Abrasive Industrial Supplies (AIS)** but that's just the beginning. We know you use belts on machines other than cylinder head resurfacers and crankshaft polishers and we're ready to meet those supply needs too.

Contact your Customer Service Representative today to get current pricing. Have AIS make something great for you!

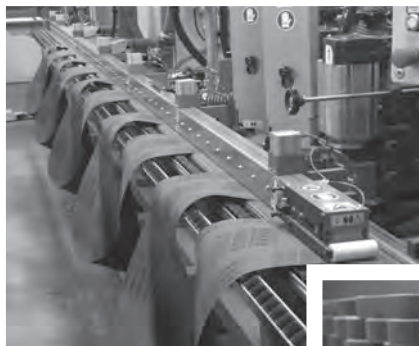

Crankshaft Polishing

Crankshaft Polishing Starter Kit

Includes 1 each of:

- Grind Aid,
- Polishing Rouge,
- Abrasive Dresser and
- 5-Pack of our most popular 72" belts
- Order No. **CP-KIT** Jobber \$62.99

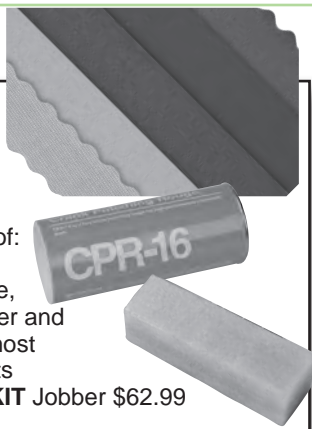

Grind Aid

- Cools and lubricates
- Reduces loading-up and grain fracturing
- Belts produce a better finish and last up to twice as long
- Use only on cloth-back belts such as those shown on pages 110 & 111
- Order No. **GRA-10** Jobber \$19.99



Polishing Rouge

- Produces high luster finish
- Use with light pressure, for cork or fine grit polishing to finish crank journals perfectly
- Hard, dry compound becomes viscous with heat
- White • 16 oz. / 454 g
- Order No. **CPR-16** Jobber \$13.99



Natural Rubber Abrasive Belt Dresser

- Prolongs belt life
- Hold at 45° angle on moving belt to remove foreign material
- Restores cutting ability of grains
- 2" x 2" x 4" / 51 x 51 x 102mm
- Order No. **ACB-224** Jobber \$9.99

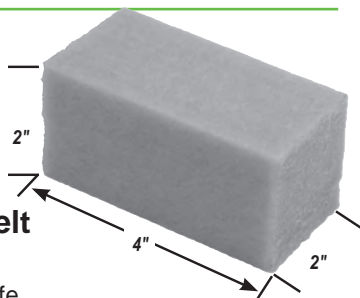

Check out the 72" Crankshaft Polisher in action! Scan the code below with the camera on your smart phone or other smart device to see the **Crankshaft Polishing** episode of **Tech Lab Tuesday**.

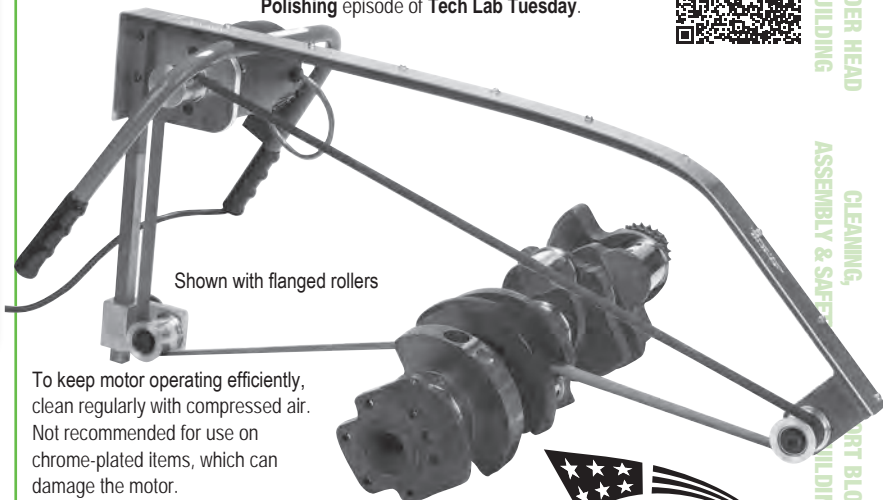

Shown with flanged rollers

To keep motor operating efficiently, clean regularly with compressed air. Not recommended for use on chrome-plated items, which can damage the motor.



Includes 5 of our most popular 72" Belts (PCP-72PAK)

tech tips from the techexperts™ *Extend the life of your polishing belts by releasing the tension when not in use.*



72" 110V Crankshaft Polisher

- Flex resistant steel frame
- Weighs 15 lbs. (6.8 kg)
- Crowned rollers keep snug belt running true
- 1" nominal = 1.625" • 2" nominal = 2.625"
- 1/2 HP motor designed for high RPM not heavy loads
- Specify flanged or unflanged rollers when ordering
- 110V, 60Hz Motor

Roller Width		HP	Max. RPM	Jobber	Order No.		
Nominal	Actual						
1"/25mm	1.625"/41mm	1/2	10,000	\$1189.99	PCP-1072		
2"/51mm	2.625"/67mm	1/2	10,000	1289.99	PCP-1072-2		
Replacement Parts and Rollers						Includes	
Flanged Roller Sets (3 piece set)	1"			\$183.99	PCP-1		▼
Unflanged Roller Sets (3 piece set)	1"			224.99	PCP-2		▼
Flanged Drive Roller	1"			204.99	PCP-1S		▼
Fits 3/8" shaft - 1 ea.	2"			214.99	PCP-2S		▼
Flanged Roller Assembly 3/8" x 16 thread - 1 ea.	1"			57.99	PCP-1D	1	1
Unflanged Roller Assembly 3/8" x 16 thread - 1 ea.	2"			62.99	PCP-2D	1	1
Bearing - 1 ea.	1"			68.99	PCP-1F		2
Replacement Switch	2"			79.99	PCP-2F		2
Flanged Roller Assembly 3/8" x 16 thread - 1 ea.	1"			83.99	PCP-1-1EA	2	
Unflanged Roller Assembly 3/8" x 16 thread - 1 ea.	2"			79.99	PCP-2-EA	2	
Bearing - 1 ea.				15.99	PCP-BRG		
Replacement Motor Brush Set (round housing)				27.99	PCP-SWITCH-72		
Replacement 110V, 60Hz Motor (square housing)				654.99	PCP-MOTOR-RS		
Retrofit Motor Adaptor (round to square housing)				78.99	PCP-RFK		
Retrofit Motor Adaptor (square to round housing)				78.99	PCP-RFK2		
Replacement Motor Brush Set (round housing)				37.99	PCP-BRUSH-72		

CYLINDER HEAD REBUILDING
CLEANING, ASSEMBLY & SAFETY
PORT BLOCK BUILDING
CRANKSHAFT/FLYWHEEL GRINDING
MISCELLANEOUS TOOLS & SUPPLIES
BRAKE SERVICE TOOLING
MEASURING TOOLS
V-TWIN & METRIC HARD PARTS

full service
...fast



"We make most of our abrasive belts in-house now. So if you need a different size belt than what you see in the catalog, give us a call. Let us make a custom belt for you."
- Josh, Abrasive Industrial Supplies Belt Technician, 1 year of service



video available

Ever wonder why Goodson offers so many crankshaft polishing belts? Watch the Tech Lab Tuesday video in which we explain the method behind our madness. Scan the code below with your smart phone or other smart device for instant access to the video.



Micro Finish Scotch-Brite Style Abrasive Rolls



- Ideal for hand polishing of high-performance crankshafts
- Non-directional polish
- Won't remove material
- Aluminum oxide abrasive
- Measures: ¾"x10' • 1 Per Box
- Order No. **GFR-750** Jobber \$36.99

Premium Ceramic Micro Polishing Belts



- Use with Polishing rouge to achieve high luster finish
- Structured Abrasive • 5 per box

Size (LxW)	Jobber	Order No.
60" x 1"	\$42.99	GSW-60x1
64" x 1"	44.99	GSW-64x1
72" x 1"	47.99	GSW-72x1
77" x 1"	59.99	GSW-77x1
Polishing Rouge	13.99	CPR-16

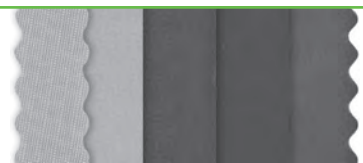

Crankshaft Polishing Belt Sample Pack

These sample packs include our most popular belts. Contents may vary.

Long	Wide	Qty.	Jobber	Order No.
64"	1"	5	\$21.99	PCP-64PAK
72"	1"	5	21.99	PCP-72PAK
72"	2"	2	21.99	PCP-72PAK-2

240 to 600 Grit Premium Ruby Aluminum-Oxide Crankshaft Polishing Belts

- Specifically for use on metal
- Closed coat J-weight cloth backing
- High strength mylar joint
- Phenolic resin-over-resin bond
- Ruby Aluminum-Oxide abrasive
- Polish better and outlast other standard polishing belts
- Color may vary due to manufacturing process

SAVE 10% off jobber!
Order 5 or more boxes of crank polishing belts (any combination)

STRAIGHT-EDGE (10 per box)							
L	W	Jobber 1+	Jobber 5+	240 Grit	320 Grit	400 Grit	600 Grit
60"	¾"	\$29.99	\$26.99	R60x¾"x240	R60x¾"x320	R60x¾"x400	R60x¾"x600
	1"	32.99	29.69	R60x1x240	R60x1x320	R60x1x400	R60x1x600
	1¼"	34.99	31.49	R60x1¼"x240	R60x1¼"x320	R60x1¼"x400	R60x1¼"x600
	1½"	36.99	33.29	R60x1½"x240	R60x1½"x320	R60x1½"x400	R60x1½"x600
	1¾"	39.99	35.99	R60x1¾"x240	R60x1¾"x320	R60x1¾"x400	R60x1¾"x600
64"	2"	41.99	37.79	R60x2x240	R60x2x320	R60x2x400	R60x2x600
	¾"	31.99	28.79	R64x¾"x240	R64x¾"x320	R64x¾"x400	R64x¾"x600
	1"	33.99	30.59	R64x1x240	R64x1x320	R64x1x400	R64x1x600
	1¼"	35.99	32.39	R64x1¼"x240	R64x1¼"x320	R64x1¼"x400	R64x1¼"x600
	1½"	37.99	34.19	R64x1½"x240	R64x1½"x320	R64x1½"x400	R64x1½"x600
72"	1¾"	40.99	36.89	R64x1¾"x240	R64x1¾"x320	R64x1¾"x400	R64x1¾"x600
	2"	42.99	38.69	R64x2x240	R64x2x320	R64x2x400	R64x2x600
	¾"	31.99	28.79	R72x¾"x240	R72x¾"x320	R72x¾"x400	R72x¾"x600
	1"	34.99	31.49	R72x1x240	R72x1x320	R72x1x400	R72x1x600
	1¼"	36.99	33.29	R72x1¼"x240	R72x1¼"x320	R72x1¼"x400	R72x1¼"x600
77"	1½"	39.99	35.99	R72x1½"x240	R72x1½"x320	R72x1½"x400	R72x1½"x600
	1¾"	42.99	38.69	R72x1¾"x240	R72x1¾"x320	R72x1¾"x400	R72x1¾"x600
	2"	45.99	41.39	R72x2x240	R72x2x320	R72x2x400	R72x2x600
	¾"	33.99	30.59	R77x¾"x240	R77x¾"x320	R77x¾"x400	R77x¾"x600
	1"	36.99	33.29	R77x1x240	R77x1x320	R77x1x400	R77x1x600
77"	1¼"	38.99	35.09	R77x1¼"x240	R77x1¼"x320	R77x1¼"x400	R77x1¼"x600
	1½"	41.99	37.79	R77x1½"x240	R77x1½"x320	R77x1½"x400	R77x1½"x600
	1¾"	44.99	40.49	R77x1¾"x240	R77x1¾"x320	R77x1¾"x400	R77x1¾"x600
	2"	47.99	43.19	R77x2x240	R77x2x320	R77x2x400	R77x2x600

All abrasives are guaranteed for 1 year from the original purchase date

Blue 800 Grit Crankshaft Polishing Belts With Scrum Back

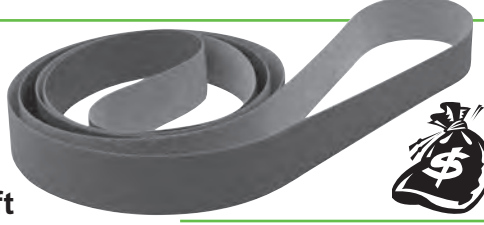

- Film substrate with aluminum-oxide abrasive
- 10 belts per box
- Mylar joint with scrum back
- Highly flexible and long lasting

Size	Jobber	Order No.
60" x ¾"	\$31.99	BF-60X3/4X800
60" x 1"	33.99	BF-60X1X800
64" x ¾"	33.99	BF-64X3/4X800
64" x 1"	52.99	BF-64X1X800
72" x ¾"	49.99	BF-72X3/4X800
72" x 1"	56.99	BF-72X1X800
77" x 1"	60.99	BF-77X1X800



Crank Welding Plug Rods

- 3 diameters available
- Each rod is 12½" long and cuts off easily
- Sharpen ends with your existing pencil sharpener
- 5 Crank Welding Plug Rods per pack

Size	Jobber	Order No.
.250"	\$16.99	CWPR-250
.312"	16.99	CWPR-312
.375"	16.99	CWPR-375



CYLINDER HEAD REBUILDING
CLEANING, ASSEMBLY & SAFETY
SHORT BLOCK REBUILDING
CRANKSHAFT/ FLYWHEEL GRINDING
MISCELLANEOUS TOOLS & SUPPLIES
BRAKE SERVICE TOOLING
MEASURING TOOLS
V-TWIN & METRIC HARD PARTS

Crankshaft Polishing Belts

10 Belts
Per Box

240, 320 & 400 Grit Standard Polishing Belts

- US CAMI Grade aluminum-oxide abrasive
- 2-layer glue bond • Fast break-in
- Use with Polishing Rouge (CPR-16) for better finish
- Highly flexible J-Weight cloth backing
- Less aggressive belts for polishing

Now With
Even More
Selection!

STANDARD STRAIGHT-EDGE (10 per box)					
Lgth	Width	Jobber	240 grit	320 grit	400 grit
60"	3/4"	\$28.99	60x3/4x240	60x3/4x320	60x3/4x400
	1"	29.99	60x1x240	60x1x320	60x1x400
	1 1/4"	35.99	60x1 1/4x240	60x1 1/4x320	60x1 1/4x400
	1 1/2"	37.99	60x1 1/2x240	60x1 1/2x320	60x1 1/2x400
	1 3/4"	39.99	60x1 3/4x240	60x1 3/4x320	60x1 3/4x400
64"	2"	42.99	60x2x240	60x2x320	60x2x400
	3/4"	27.99	64x3/4x240	64x3/4x320	64x3/4x400
	1"	37.99	64x1x240	64x1x320	64x1x400
	1 1/4"	36.99	64x1 1/4x240	64x1 1/4x320	64x1 1/4x400
	1 1/2"	38.99	64x1 1/2x240	64x1 1/2x320	64x1 1/2x400
70"	1 3/4"	40.99	64x1 3/4x240	64x1 3/4x320	64x1 3/4x400
	2"	42.99	64x2x240	64x2x320	64x2x400
	3/4"	33.99	70x3/4x240	70x3/4x320	70x3/4x400
	1"	35.99	70x1x240	70x1x320	70x1x400
	1 1/4"	37.99	70x1 1/4x240	70x1 1/4x320	70x1 1/4x400
72"	1 1/2"	39.99	70x1 1/2x240	70x1 1/2x320	70x1 1/2x400
	1 3/4"	41.99	70x1 3/4x240	70x1 3/4x320	70x1 3/4x400
	2"	43.99	70x2x240	70x2x320	70x2x400
	3/4"	32.99	72x3/4x240	72x3/4x320	72x3/4x400
	1"	37.99	72x1x240	72x1x320	72x1x400
77"	1 1/4"	38.99	72x1 1/4x240	72x1 1/4x320	72x1 1/4x400
	1 1/2"	40.99	72x1 1/2x240	72x1 1/2x320	72x1 1/2x400
	1 3/4"	42.99	72x1 3/4x240	72x1 3/4x320	72x1 3/4x400
	2"	44.99	72x2x240	72x2x320	72x2x400
	3/4"	36.99	77x3/4x240	77x3/4x320	77x3/4x400
77"	1"	38.99	77x1x240	77x1x320	77x1x400
	1 1/4"	40.99	77x1 1/4x240	77x1 1/4x320	77x1 1/4x400
	1 1/2"	42.99	77x1 1/2x240	77x1 1/2x320	77x1 1/2x400
	1 3/4"	44.99	77x1 3/4x240	77x1 3/4x320	77x1 3/4x400
	2"	46.99	77x2x240	77x2x320	77x2x400

All abrasives are guaranteed for 1 year from the original purchase date

SAVE 10% off jobber!

Order 5 or more boxes of crank polishing belts (any combination)

Standard Scalloped Edge Crankshaft Polishing Belts

- 10 per box • 320 grit • 1" wide
- Ideal for radius polishing
- Double layer urea glue bond CAMI grade polishing belts

Length	Jobber 1+	Jobber 5+	Order No.
64"	\$39.99	\$35.99	S64x1x320
72"	42.99	38.69	S72x1x320



Fine Finish

- Gold Aluminum-oxide • Flexible, woven blue backing • Very aggressive
- Phenolic Resin-Over-Resin bond
- Sharper grains cut faster without sacrificing finish • Use with Grind Aid (GRA-10) or Polishing Rouge (CPR-16) for cooler polishing or grinding

Fine Finish (10 per box)

Length	Width	Jobber	320 grit	Jobber	400 grit
60"	1"	\$39.99	G-60x1x320	\$39.99	G-60x1x400
64"	1"	41.99	G-64x1x320	41.99	G-64x1x400
72"	1"	44.99	G-72x1x320	44.99	G-72x1x400
77"	1"	47.49	G-77x1x320	47.49	G-77x1x400

Scotch-Brite Style Micro Finish

- Rigid, 3-dimensional back • Resin bond • Aluminum-oxide abrasive • Non-directional Satin finish
- Use with Grind Aid (GRA-10)

Micro-Finish (1 per box)

Length	Width	Jobber	Order No.
60"	3/4"	\$27.99	GFB-60 x 3/4
	1"	27.99	GFB-60 x 1
64"	3/4"	29.99	GFB-64 x 3/4
	1"	29.99	GFB-64 x 1
70"	3/4"	30.99	GFB-70 x 3/4
	1"	30.99	GFB-70 x 1
72"	3/4"	31.99	GFB-72 x 3/4
	1"	31.99	GFB-72 x 1
77"	1"	33.99	GFB-77 x 1
	91"	1"	36.99

Scotch-Brite Style Super-Micro Finish

- Produces a mirror-like non-directional finish
- Resin bond • Silicon-Carbide abrasive
- For final Satin finish • Use with Grind Aid (GRA-10)

Super-Micro Finish (1 per box)

Length	Width	Jobber	Order No.
60"	3/4"	\$26.99	SGFB-60 x 3/4
	1"	26.99	SGFB-60 x 1
64"	3/4"	27.99	SGFB-64 x 3/4
	1"	27.99	SGFB-64 x 1
70"	3/4"	28.99	SGFB-70 x 3/4
	1"	28.99	SGFB-70 x 1
72"	3/4"	29.99	SGFB-72 x 3/4
	1"	29.99	SGFB-72 x 1
77"	3/4"	30.99	SGFB-77 x 3/4
	1"	30.99	SGFB-77 x 1

Abrasive Cork Super-Fine Finish

- Won't disturb polished radii
- Silicon-carbide • Use with Polishing Rouge (CPR-16) for High Luster finish

Abrasive Cork (1 per box)

Length	Width	Jobber	Order No.
64"	3/4"	\$14.99	CPB-64-3/4
	1"	14.99	CPB-64-1
70"	3/4"	14.99	CPB-70-3/4
	1"	14.99	CPB-70-1
72"	3/4"	14.99	CPB-72-3/4
	1"	14.99	CPB-72-1
77"	3/4"	14.99	CPB-77-3/4
	1"	14.99	CPB-77-1



Custom Belt Sizes Available

CYLINDER HEAD REBUILDING
CLEANING, ASSEMBLY & SAFETY
SHORT BLOCK REBUILDING
CRANKSHAFT/FLYWHEEL GRINDING
MISCELLANEOUS TOOLS & SUPPLIES
BRAKE SERVICE TOOLING
MEASURING TOOLS
V-TWIN & METRIC HARD PARTS

... another satisfied customer



"Goodson was able to help me select the right grinding stones for our racing clutch and flywheel program. Their support and technical advice is always available to keep our program on the right track."

- Johnny Ahten, Johnny Ahten Racing - Goodson customers since 2005

CYLINDER HEAD REBUILDING

CLEANING, ASSEMBLY & SAFETY

SHORT BLOCK REBUILDING

CRANKSHAFT/ FLYWHEEL GRINDING

MISCELLANEOUS TOOLS & SUPPLIES

BRAKE SERVICE TOOLING

MEASURING TOOLS

V-TWIN & METRIC HARD PARTS

Flywheel Radius Cutter Tip Holder

- For Winona Van Norman/ Van Norman FG-5000
- Holder measures 1.5"L with a .312" dia. shank
- Includes 1 indexable FG-3B cutter tip

Description	Jobber 1+	Jobber 10+	Order No.
Tip Holder	\$149.99		FG-5011
Replacement Tip	13.99	12.59 ea.	FG-3B

FG-3B

Order 10 or more, take 10% off jobber!

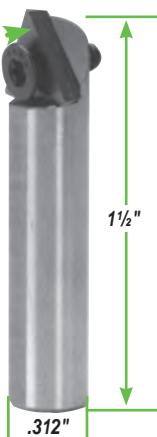

Flywheel Grinding Coolant

- Formula eliminates rancid coolant
- Synthetic inhibitors
- Dilute 30:1 (water:coolant)

Size	Jobber	Order No.
1 Gal. / 3.78L	\$ 44.99	FG-1101-G
5 Gal. / 18.8L	159.99	FG-1102-G



Order 5 or more, take 10% off jobber!

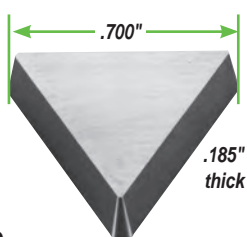

Flywheel Cutter Tip For Winona Van Norman 570 Rotary Broach

- 3-edge carbide cutting tip for use with the special flywheel attachment
- Order VN-FW Jobber \$19.99 each
- Order 5+, Jobber \$17.99

Flywheel Depth Gauge with Dial Indicator

- Measure flywheel before and after grinding to maintain proper depth specifications
- Gauge Assembly includes Dial Indicator, Bar & Magnets
- Spindle Extensions sold separately

Description	Jobber	Order No.
Gauge Assembly	\$139.99	FGG-12
Spindle 1.5"	14.99	DIS-1.5
Extensions 2.5"	13.99	DIS-2.5
3.0"	18.99	DIS-3.0

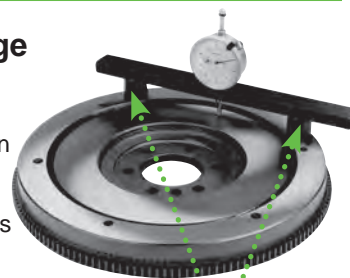

Magnetic feet adjust to flywheel diameter

Flywheel Grinder Bolt Adaptors

- Replace shoulder bolts with standard hardware
- Low-cost adaptor converts any 1/2" or 7/16" bolt to a 3/4" ID
- Includes countersunk adaptor with bolts for extra clearance



FG-LOCK

Fits	Size	Jobber	Order No.
DCM, Peterson, KW	1/2" x 13	\$36.99	FG-DCP-KIT
WVN	7/16" x 14	36.99	FG-AB-KIT
WVN Table Insert	OD: 5/8" x 11, ID: 7/16" x 14	7.49	FG-LOCK

Flywheel Grinder Table Lubricant

- Extend flywheel grinder life
- High pressure oil designed to lubricate table bearings and ways
- For all makes of flywheel grinders
- 1 Gal. (3.78L)
- Order No. FG-1131-G
- Jobber \$43.99



FG-1165-G



FG-1070A-G



FG-1045-G



GS-17



GS-00



GS-0

Grinding Wheel Dressers & Replacement Cutters

Diamond Dresser Tools are available on pages 116-117

Applications	Cutter Assemblies				Replacement Cutters						
	OD	W	Jobber	Order No.	Pieces	Washers	OD	ID	Thick	Jobber	Order No.
Peterson (12mm shaft)					8 stars	3	2.375"	1.50"	.093"	\$29.99	GS-17
						1 w/locking tangs	1.75"	1.50"	.060"		
WVN SM2000, 4000, 5000, 6000C, 6000A, MG3000, 3850	1.250"	.978"	\$32.99	FG-1165-G	7 stars	none	1.25"	0.313"	.095"	8.99	FG-1161-G
Peterson & DCM	2.375"	2.262"	84.99	FG-1070A-G	5 stars		2.375"	1.132"	.1375"	18.99	FG-1070-G
Hand held			56.99	FG-1045-G	1 stone	none	1.50"	0.313"	.6250"	14.99	FG-1044-G
Desmond-Style Dresser for wheels to 10"			24.99	GS-0	4 blades, 2 spacers		0.250"			8.99	GS-00
					4 blades, 2 spacers		0.500"			9.99	GS-11

Crankshaft & Flywheel Tools

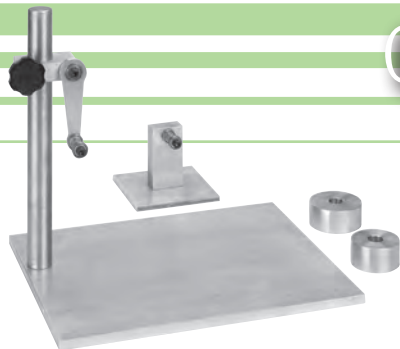

Rod Balancing Stand

- Ideal for static balancing parts
- Also use to weigh rotating and reciprocating masses and record the information for dynamic balancing
- Heavy-duty steel construction
- Includes 1-2" (50.8mm) and 1-2.3" (58.4mm) support discs
- Height adjustment accommodates different rod sizes
- Order No. **BS-201** Jobber \$309.99



6100 Gram Balancing Scales

- Scales feature automatic tare weight correction
- 1.0 Gram / 0.100 Ounce increments
- Operates on 9V battery (not included) or 110V converter (included) • Low battery indicator
- Order No. **BS-6100** Jobber \$639.99

Pin Pal Puller

- Remove dowels fast
- Adjusts to pull all sizes of dowels
- Locking pliers with special hardened jaws hold firm while 4 lb. slide hammer forces dowels out
- Also pulls pressed-in hollow tubes or frozen shafts
- Rugged steel construction



Description	Jobber	Order No.
Complete Tool	\$419.99	GA-300
Replacement Jaws	119.99	GA-300E-R



Mirrored Safety Glasses

- Wrap-around design
- Tinted lenses provide sun glare protection
- Universal bridge
- Polycarbonate lenses
- Do not use as welders helpers
- Order No. **PGL-21** Jobber \$6.49

Heavy Metal

An essential component when balancing rods & pistons to crankshafts to ensure proper engine operation. Contains 90% Tungsten



HEAVY METAL - TUNGSTEN 90%

Hole in	Press Fit + in/mm	1.0" Long			1.2" Long		
		Grams	Jobber	Order No.	Grams	Jobber	Order No.
1/2"	.002"/.05	57	\$23.99	HM-57	65	\$32.99	HM-72
3/4"	.002"/.05	122	29.99	HM-122	147	34.99	HM-162
7/8"	.002"/.05	169	39.99	HM-169	198	46.99	HM-198
1"	.002"/.05	227	53.99	HM-227	265	61.99	HM-265

NOTE: Due to market fluctuations, heavy metal prices are subject to change without notice. Please confirm pricing when ordering.

tech tips

from the techxperts™

It is essential, when pulling a dowel, that the tightening sleeve is installed with the flared end toward the collet. This will allow the tightening sleeve to slide over the collet, locking it to the dowel you are removing. Also, be sure to select the correct collet size for the dowel you are removing.



Scan the code below on your smart phone or other smart device to watch our How-To video on Dowel Pulling.



Dowel Puller and Collets

- Slide hammer action removes stubborn dowels
- Use on blocks, heads, flywheels, etc.
- Split collets grip firmly without causing damage
- A high-quality tool that lets you reuse dowel pins
- Choose from SAE or Metric kits
- All items also sold separately

Description	Jobber	Order No.	Incl.
Standard Kit	\$199.99	GA-600	▼
Metric Kit	199.99	GA-600M	▼
Slide Shaft (14" L)	17.99	GAO-1	x x
Slide Hammer	24.99	GAO-2	x x
Tightening Sleeve	39.99	GAO-3	x x
Gripping Collets			
OD	ID	mm	
1"	.1575"	4.00	\$37.99 GAO-22 x
1"	.1875"	4.76	37.99 GAO-4 x
1"	.1969"	5.00	37.99 GAO-13 x
1"	.2362"	6.00	37.99 GAO-14 x
1"	.2500"	6.35	37.99 GAO-5 x
1"	.2756"	7.00	37.99 GAO-26 x
1"	.3125"	7.94	37.99 GAO-6 x
1"	.3150"	8.00	37.99 GAO-10 x
1"	.3750"	9.53	37.99 GAO-7 x
1"	.3937"	10.00	37.99 GAO-23 x
1"	.4375"	11.11	37.99 GAO-8 x
1"	.4724"	12.00	37.99 GAO-24 x
1"	.5000"	12.70	37.99 GAO-9 x
1"	.6250"	15.88	37.99 GAO-20 x
Removal Basin	32.99	GAO-21	x x

Parts are stamped for easy identification & reordering

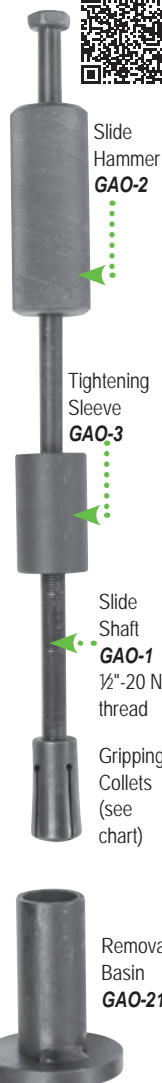

CYLINDER HEAD
REBUILDING

CLEANING,
ASSEMBLY & SAFETY

SHORT BLOCK
REBUILDING

CRANKSHAFT/
FLYWHEEL, GRINDING

MISCELLANEOUS
TOOLS & SUPPLIES

BRAKE SERVICE
TOOLING

MEASURING
TOOLS

V-TWIN & METRIC
HARD PARTS

Flywheel Grinding Stones

CYLINDER HEAD REBUILDING
CLEANING, ASSEMBLY & SAFETY
SHORT BLOCK REBUILDING
CRANKSHAFT/ FLYWHEEL GRINDING
MISCELLANEOUS TOOLS & SUPPLIES
BRAKE SERVICE TOOLING
MEASURING TOOLS
V-TWIN & METRIC HARD PARTS

For Best Results... Choose The Right Flywheel Stone From Goodson

Goodson stones feature 50% more usable abrasive and much stronger construction, yet sell at prices comparable to ordinary stones. With Goodson stones you'll get longer wheel life and lower-cost flywheel grinding.

Cast Iron:

Cast Iron (soft) flywheels need to be ground with harder stones. Experiment to find the best stone. A starting point is the FGW-57, our best all-around stone for Cast Iron.

Cast Steel:

Cast Steel (medium) flywheels require medium-hard stones. The FGW-65 is our best all-around stone for Cast Steel.

Billet Steel:

Billet Steel (very hard) flywheels need to be ground with softer stones. Our best all-around stone for Billet Steel is the FGW-50-2. It's our most friable and free-cutting, requiring minimal dressing.

video available Goodson carries a wide selection of flywheel grinding stones. Watch as we unpack the reasons why in our **Tech Lab Tuesday** video "Choosing the Right Flywheel Stone." Scan the code at right with your smart phone or other smart device for instant access.



Coolant on pages 76 and 103

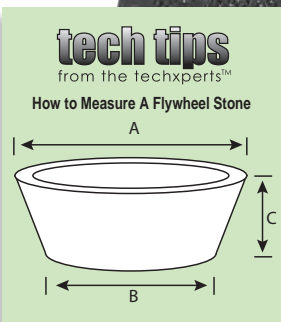

tech tips
from the techxperts™ Be sure to use ample coolant to flush away swarf and help the stones perform better.

Silicon-Carbide Abrasive

CAST IRON (Passenger cars, light trucks)

A	B	C	Arbor	Description	Jobber 1+	Jobber 5+	Order No.
6"	4½"	2½"	1¼"	Harder than FGW-57, lasts longer, black	\$54.99	\$49.49	FGW-67
6"	4½"	2½"	1¼"	Best all-around for cast iron, black	57.99	52.19	FGW-57
6"	—	2½"	1¼"	Straight-sided FGW-57, black	55.99	50.39	FGW-57S
6"	4½"	2½"	1¼"	Softer than FGW-57, grinds faster, black	53.99	48.59	FGW-47
6"	4¾"	2⅞"	1¼"	Silicon-carbide, ideal for top fuel, black	53.99	48.59	FGW-37
6"	4¾"	2⅞"	1¼"	Silicon-carbide, softer, finer grit than FGW-37	57.99	52.19	FGW-37F
4"	3"	2"	1¼"	Small diameter FGW-57, black	74.99	67.49	FGW-61
4"	3"	2"	1¼"	Small diameter FGW-37, black	32.99	29.69	FGW-374
3"	—	2"	1¼"	Straight-sided green silicon-carbide, premium	32.99	29.69	FGW-93

Silicon-Carbide/Aluminum-Oxide Combination

CAST STEEL (Industrial, agricultural, OTR trucks)

A	B	C	Arbor	Description	Jobber 1+	Jobber 5+	Order No.
6"	4½"	2"	1¼"	Harder than FGW-65 lasts longer, lt. gray	\$ 74.99	\$67.49	FGW-53
6"	4½"	2½"	1¼"	Best all-around for Cast Steel, speckled	107.99	97.19	FGW-65
6"	4½"	2½"	1¼"	Slightly softer than FGW-65, black	57.99	52.19	FGW-49S
4"	3"	2"	1¼"	Small diameter FGW-65, speckled	51.99	46.79	FGW-69
6"	4½"	2½"	1¼"	Softer than FGW-65, grinds faster, black	92.99	83.69	FGW-49

Aluminum-Oxide Abrasive

BILLET STEEL (Import vehicles, high-performance)

A	B	C	Arbor	Description	Jobber 1+	Jobber 5+	Order No.
6"	4½"	2½"	1¼"	Harder, ruby stone, lasts longer	\$101.99	\$91.79	FGW-64
6"	4½"	2½"	1¼"	Harder, pink stone, lasts longer	109.99	98.99	FGW-62-1
6"	4½"	2½"	1¼"	Harder than FGW-50-2	82.99	74.69	FGW-50
6"	4½"	2½"	1¼"	Best all-around for Billet Steel	97.99	88.19	FGW-50-2
4"	3½"	1½"	1¼"	Harder, pink stone, lasts longer	49.99	44.99	FGW-63-1
4"	3"	2"	1¼"	Taller than FGW-56, more abrasive, white	56.99	51.29	FGW-306
4"	3½"	1½"	1¼"	Premium	44.99	40.49	FGW-56P
4"	3½"	1½"	1¼"	Small diameter, off white	36.99	33.29	FGW-56
3"	2¼"	1¼"	¾"	Small diameter, light gray	34.99	31.49	FGW-59
3"	—	2"	1¼"	Straight-sided sugar white stone	29.99	26.99	FGW-92

NOTE: Due to manufacturing process, colors may vary.

All abrasives are guaranteed for 1 year from original purchase date.

10% off jobber! Order 5 or more flywheel grinding stones (any combination)



Mounting Adaptor For Small Diameter Stones

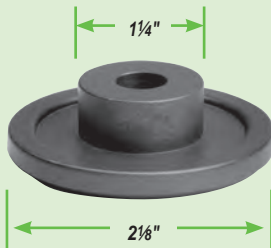

- Many flywheel grinders have lower mounting flanges that won't fit inside 3" and 4" diameter flared-cup stones
- Use this adaptor to avoid damage when mounting small stones
- Fits most small diameter stones
- Order No. **FG-FLANGE**
Jobber \$47.99

tech tips

from the techxperts™

Never dress your Superabrasive with the dresser attachment on your machine. Use our CBN dressing stick for best results.



FlyMaster® CBN Super Abrasive Flywheel Grinding Wheels

• For cast iron • Light to heavy applications

A	B	C	Arbor	Shape	Grit	Jobber 1+	Jobber 5+	Order No.
2"	2"	0.4"	3/8"	Straight	100	\$219.99	\$197.99	CBN-200
3"	3"	0.4"	3/8"	Straight	100	236.99	213.29	CBN-300
2"	1 3/8"	7/8"	3/8"	Cup	100	154.99	139.99	2H0998
3"	2"	1 1/4"	1 1/4"	Cup	100	244.99	220.49	261453
3 3/4"	2 5/8"	1 1/2"	1 1/4"	Cup	100	229.99	206.99	2371052
3 3/4"	2 5/8"	1 1/2"	1 1/4"	Cup	60	219.99	197.99	34296362
5"	3 3/4"	1 3/4"	1 1/4"	Cup	100	251.99	226.79	2379270
6"	4 5/8"	1 5/8"	1 1/4"	Cup	100	236.99	213.29	2367275*
6"	4 5/8"	1 5/8"	1 1/4"	Cup	60	278.99	251.09	2G7480
CBN Dressing Stick 1/2" x 1/2" x 6"						19.99		DS-CBN

*Most popular application

Order 5 or more Flywheel Grinding Stones (any combination) and SAVE 10% off Jobber



Flywheel Grinding Stones

• Four Abrasive formulas to choose from

SILICON-CARBIDE ABRASIVE

Ductile Iron, Cast Iron & Steel (Black)

A	B	C	Arbor	Hardness	Shape	Jobber 1+	Jobber 5+	Order No.
3"	2 1/2"	1 1/2"	1 1/4"	Med. Hard	Flared	\$47.99	\$43.19	U364512
4"	3"	2"	1 1/4"	Med. Soft	Flared	86.99	78.29	U335369
6"	4 1/2"	2 1/2"	1 1/4"	Med. Soft	Flared	54.99	49.49	U324495
6"	4 1/2"	2 1/2"	1 1/4"	Med. Hard	Flared	61.99	55.79	U335376
6"	4 1/2"	2 1/2"	1 1/4"	Hard	Flared	51.99	46.79	U335377
6"	4 1/2"	2 1/2"	1 1/4"	Med. Soft	Flared	57.99	52.19	U357854
6"	4 1/2"	2 1/2"	1 1/4"	Med. Hard	Flared	78.99	71.09	U343805

EXTENDED LIFE CERAMIC

Ductile Iron, Cast Iron and Steel (Black)

A	B	C	Arbor	Hardness	Shape	Jobber 1+	Jobber 5+	Order No.
6"	4 1/2"	3"	1 1/4"	Med. Hard	Flared	\$131.99	\$118.79	U370095

ALUMINUM-OXIDE ABRASIVE

Mild Steel & Hardened Steel (White)

A	B	C	Arbor	Hardness	Shape	Jobber 1+	Jobber 5+	Order No.
6"	4 1/2"	2 1/2"	1 1/4"	Soft	Flared	\$123.99	\$111.59	F342636

ALUMINUM-OXIDE ABRASIVE

Light to Medium Stock Removal on Steel, Cast Iron & Ductile Iron (Ruby)

A	B	C	Arbor	Hardness	Shape	Jobber 1+	Jobber 5+	Order No.
4"	3"	2"	1 1/4"	Medium	Flared	\$66.99	\$60.29	F348769
6"	4 1/2"	2 1/2"	1 1/4"	Soft	Flared	57.99	52.19	F372039
6"	4 1/2"	2 1/2"	1 1/4"	Med. Soft	Flared	57.99	52.19	F348771
6"	4 1/2"	2 1/2"	1 1/4"	Medium	Flared	71.99	64.79	F348772
6"	4 1/2"	2 1/2"	1 1/4"	Hard	Flared	81.99	73.79	F348773

Colors may vary due to the manufacturing process

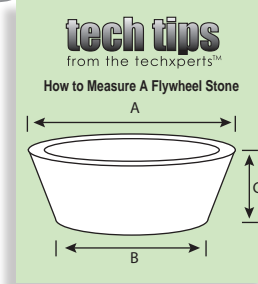

Diamond Flywheel Grinding Wheel

- For hard, spray coated floaters and flywheels
- **Not for use on cast iron or steel flywheels**
- A = 6" | B = 4 5/8" | C = 1 7/8" | Arbor = 1 1/4"
- Order No. **2E5742** Jobber 1+ \$224.99
Jobber 5+ \$202.49



3/4" Thick Wall for Faster, More Aggressive Grinding



Big Brute™ Flywheel Grinding Stone

- Medium-Hard Silicon Carbide abrasive formula • Extra beefy for better grinding
- Measurements: A = 6" | B = 4 3/4" | C = 3" | Arbor = 1 1/4" (see graphic above)
- Order No. **U69693**
Jobber 1+ \$57.99 or Jobber 5+ \$52.19

CYLINDER HEAD REBUILDING
CLEANING, ASSEMBLY & SAFETY
SHORT BLOCK REBUILDING
CRANKSHAFT/FLYWHEEL GRINDING
MISCELLANEOUS TOOLS & SUPPLIES
BRAKE SERVICE TOOLING
MEASURING TOOLS
V-TWIN & METRIC HARD PARTS

Diamond Dresser Tools

shown at approximately full size

CYLINDER HEAD
REBUILDING

CLEANING,
ASSEMBLY & SAFETY

SHORT BLOCK
REBUILDING

CRANKSHAFT/
FLYWHEEL GRINDING

MISCELLANEOUS
TOOLS & SUPPLIES

BRAKE SERVICE
TOOLING

MEASURING
TOOLS

V-TWIN & METRIC
HARD PARTS



Diamond: Selected for very high point definition. A sharper diamond cuts faster and gives a superior finish.

Matrix: Matrix material is bronze or copper-based for a tight hold on the diamond & high heat transfer.

Holder: Cold rolled steel. Threaded types have precision threads over a long distance to screw easily into tool holders and support cutting point firmly to prevent vibration.

Diamonds are stamped for easy identification and re-ordering

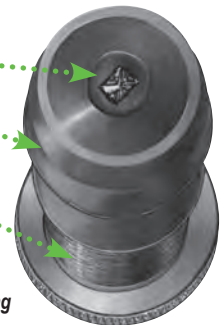

Premium Diamond Resetting Service:

Send your worn premium diamonds to Goodson for fast resetting. Prices quoted upon request. Reset when wear facets exceed $\frac{1}{16}$ " on a $\frac{1}{2}$ to $\frac{3}{8}$ carat diamond and $\frac{1}{8}$ " on a 1 carat or larger.

Diamond Dressers for most shop machines are in stock and ready-to-ship

A diamond tool is only as good as the diamond itself. GOODSON diamonds are furnished by the most respected supplier in the U.S. Each is subjected to a microscopic examination by experts and must meet strict standards to be accepted. This rigorous inspection and careful control during manufacturing assures consistent high quality. Our diamond tools deliver the highest levels of performance and longevity.

In addition to our standard diamond tools, GOODSON stocks a wide selection of Premium Quality diamonds. These diamonds last longer and improve wheel performance. They stay sharp longer and have more points so they can be reset more times. Because of this quality, they will dress harder wheels and wheels will need to be dressed less frequently. If you don't see the diamond you need in a premium quality, call 1-800-533-8010 for a special order.

	Machine	Description	Carat	Jobber	Standard	Jobber	Premium
Valve Refacers	B&D, Skil, Sioux™, Thor, VanDorn, WVN	3/8" x 1 1/8"	1/5	\$ 42.99	G-1	\$ 84.99	G-1P
	Kwik-Way, Tobin Arp (S&D)	5/16" x 2 1/2"	1/5	42.99	G-3	—	—
	Kwik-Way, Valve Master (1714)	1/2" x 3 1/4" 20NF	1/5	44.99	G-4	—	—
	Sioux™ (1713, 1715), IDL, WVN (CG50, CG80)	3/8" x 2 3/4" 24NF	1/5	44.99	G-5	84.99	G-5P
	IDL, WVN (CG-50, CG-80)	3/8" x 3 1/4" 24NF	1/5	49.99	G-80	—	—
	US	7/16" x 2"	1/5	44.99	G-6	—	—
	Skil (Talent)	5/16" x 2 1/4" 18NC	1/5	44.99	G-9	—	—
Valve Seat Grinders	Kwik-Way	7/16" x 2 3/4" 20NF	1/5	42.99	G-17	84.99	G-17P
	B&D, S&D, Van Dorn	3/8" x 2 1/4" 24NF	1/5	44.99	G-2	—	—
	Kwik-Way	1/2" x 3 1/4" 20NF	1/5	44.99	G-4	—	—
	Sioux™ (1715), K-W (NSG), Thor	3/8" x 2 3/4" 24NF	1/5	44.99	G-5	84.99	G-5P
	Hall HD (13-1938P), Skil, Snap-On, B&D	5/16" x 2 1/4" 24NF	1/5	48.99	G-8	81.99	G-8P
	KO Lee, Skil	5/16" x 2 1/4" 18NC	1/5	44.99	G-9	—	—
	Sioux™ Heavy Duty (1715B, 1719)	3/8" hex RH thread	1/5	67.99	G-11	—	—
Clutch Grinders	Goodson Universal Wheel Dresser	8mm x 1.25mm	1/5	—	—	94.99	G-13P
	Sioux™ Heavy Duty (1715A)	3/8" x 2 3/4" 24NF	1/2	87.99	G-15	—	—
	Kwik-Way Heavy Duty Wheel Dresser	1/2" x 3" 20NF	1/5	44.99	G-18	78.99	G-18P
	Lempco AC, NAC, VAC & Do-ALL	7/16" x 2"	1/5	44.99	G-6	—	—
Piston Grinders	Van Norman 75, 76 & Relio	3/8" x 1 1/8"	1/5	42.99	G-1	84.99	G-1P
	Storm-Vulcan D-3	7/16" x 2"	1/5	44.99	G-6	—	—
Drum Lathes	Van Norman (all except 302, 302H)	3/8" x 1 1/8"	1/5	42.99	G-1	84.99	G-1P
	Barret, V.N. 302, 302H	3/8" x 3"	1/5	42.99	G-1L	—	—
	Lempco	7/16" x 2"	1/5	44.99	G-6	—	—
	Ammco 5000	1/2" x 1 1/2"	1/5	44.99	G-19	—	—
Rod Grinders	Sunnen® Rod & Cap Grinder (CRG-500)	3/8" x 1 1/8"	1/5	42.99	G-1	84.99	G-1P
	Storm-Vulcan No. 65 Rod Grinder	1/2" x 3 1/4" 20NF	1/5	44.99	G-4	—	—
Crank & Cam Grinders	Storm-Vulcan 14, 15, 15A, 15C, 75, 75A	1/2" x 3"	3/4	154.99	G-25	—	—
		1/2" x 3"	1	207.99	G-25A	—	—
	Scledum	10mm x 1 1/8"	3/4	154.99	G-27	—	—
	Winona Van Norman/Zanrosso,	7/16" x 1 1/4", 5/8" head	3/4	154.99	G-30	—	—
	Lempco, Landis	7/16" x 1 1/4", 5/8" head	1	219.99	G-30A	—	—
	Berco	tapered, step type	1	229.99	G-32A	359.99	G-32AP
	Berco	tapered, step type	1 1/2	369.99	G-32B	—	—
Flywheel Grinder	Storm-Vulcan, WVN CG210, 250, 280	1/2" x 2" 70° radius dress	3/4	279.99	G-33	—	—
	Kwik-Way 796	7/16" x 2"	1/5	44.99	G-6	—	—

tech tips

from the techxperts™

- 1. Set tool at a proper angle.** Position at 10° to 15° from surface. Smaller angles blunt the diamond. Larger angles may cause the wheel to remove matrix material.
- 2. Prevent vibration in the holder.** Any looseness in the tool holder will allow vibration of the tool resulting in poor finish on the wheel.

- 3. Turn coolant on before dressing.** Wheels used wet should be dressed wet. To keep diamond cool, turn coolant on before starting to dress. (If wheel is dressed dry, air-cool diamond between cuts but don't quench with water.)
- 4. Start at highest point.** Wheels often wear unevenly & may have high & low spots. Set tool to dress high spots first, feed in about .001" per pass until done. This prevents overheating & damage.

- 5. Use steady travel.** Uneven travel causes an uneven finish. The best rate is found by experiment, but whatever the rate of travel, it must be even.
 - 6. Turn the tool in the holder.** Turn the tool often to expose new diamond surface to the wheel.
 - 7. Don't bump or drop diamond.** They are hard but brittle, and can be harmed if dropped or bumped.
- CAUTION: Grinding Wheel must never touch the matrix or holder.**

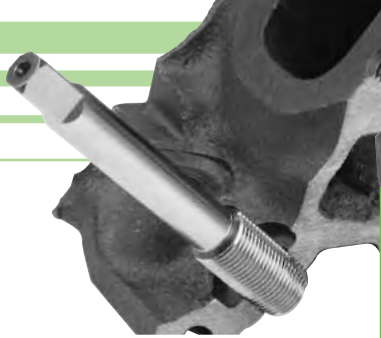

14mm Spark Plug Thread Chaser/Burnisher

- Ideal for spark plug hole cleaning
- Re-forms the original material by burnishing, not cutting, and won't create new chips to clean out
- Order No. **SPB-14** Jobber \$118.99

Burr Buster

- Use on air float tables, seat & guide machines, beds of crankshaft grinders and flywheel grinder tables
- Deburrs gasket surfaces on heads, blocks, manifolds, etc.
- 120 grit premium grade abrasive
- 1½" x 2¾" x 9"
- Order No. **BB-9** Jobber \$35.99



Premium Tapered Reamer

- Use by hand or with a powered driver to deburr or enlarge tapered holes for valve guides, bolt hole chamfering, and more
- Use in ½" chuck at approx. 40 RPM
- OAL: 5¾" • Flute Length: 3¾"
- Small End: 1/8" dia.
- Large End: 1/2" dia.
- Order No. **TR-216-1** Jobber \$39.99



Maxxeon® WorkStar® 364 USB Rechargeable UV Leak Detection Pen/Inspection Light

- 3.7V 570mAh, 2.1 Wh Lithium battery with USB charger
- Run time: 35 min. continuous, 2 hr. intermittent operation
- Use with Goodson Glow or Magnetic Crack Detection Oil (page 55)
- Easily adjustable beam to suit application
- Drop tested to 6 feet
- Order No. **DFL-364** Jobber \$44.99



Maxxeon® WorkStar® 360 Rechargeable LED Pen/Inspection Light

- No batteries to replace! Includes Micro USB charger
- 3X zoom provides 160 Lumens on low
- 1X zoom provides 260 Lumens on high
- 40 minute continuous or 2-hour intermittent operation
- Dust-tight, waterproof to 3 feet
- Drop tested to 6 feet
- Order No. **DFL-360** Jobber \$43.99

Maxxeon® WorkStar® 810 CYCLOPS Rechargeable LED Work Light

- Puts the light right where you need it • Drop tested to 6'
- Li-ion battery with USB charger
- 3 light settings
- Magnetic base attaches the light to your machine
- Order No. **DFL-810** Jobber \$34.99



Bench Grinder Wheels

- 40 and 60 grit for general grinding
- 100 grit for sharpening carbide tools
- Includes bushings to reduce arbor hole from ¾" to ½"
- PLUS a ⅝" bushing adaptor

Size	Grit	Jobber	Order No.
General Purpose Wheels: For steel and cast iron			
6" x ¾"	60	\$28.99	GG-666
6" x 1"	60	28.99	GG-686
8" x 1"	60	35.99	GG-886
Green Grit Wheels: For sharpening carbide tools			
6" x ½"	100	\$30.99	GCG-641
6" x ¾"	100	37.99	GCG-661
6" x 1"	100	46.99	GCG-681

GS-00



GS-0



Grinding Wheel Star Dressers

Description	Jobber	Order No.
Desmond-Style Hand Dresser for Wheels to 10" Dia.	\$24.99	GS-0
Replacement Cutter Sets		
4 Blades, 2 Spacers, ¼" ID for GS-0 dresser	\$8.99	GS-00
4 Blades, 2 Spacers, ½" ID for GS-1 dresser	9.99	GS-11

Deburring Wheels for Bench Grinders

- Medium-hard wheels are better suited for heat sensitive materials
- Use to clean and polish white metal
- Buff and Blend Wheels deliver the same results as a wire brush but are much safer to work with



Description	Size	Qty.	Jobber	Order No.
Medium-Hard Deburring Wheel	6" x 1" x 1"	1	\$102.99	SCW-68M
Buff and Blend Wheels	6" x ½" x 1"	5	20.99	BBD-65

Brake Lathe Replacement Tips

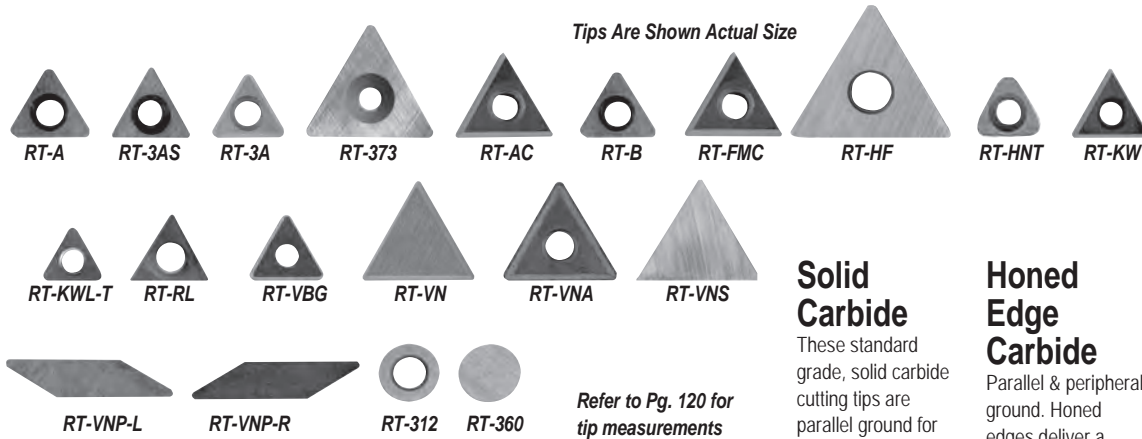

Tips Are Shown Actual Size

Buy 3 or More 10-Packs (mix & match), SAVE 10% off Jobber

Solid Carbide

These standard grade, solid carbide cutting tips are parallel ground for resurfacing cast iron drums and rotors.

Honed Edge Carbide

Parallel & peripheral ground. Honed edges deliver a better finish on cast iron and composite rotors.

Titanium

Premium grade titanium coated carbide. Parallel and peripheral ground for ultimate performance on cast iron & composite rotors.

Refer to Pg. 120 for tip measurements

10 Pack Brake Lathe Replacement Tips

Machine	Model(s)	OE No.	Edges	Rake	Screws	Jobber	Order No.	Jobber	Order No.	Jobber	Order No.
Ammco	700, 710, OTC Lathes, 1000, 2002, 3000, 4000, 4100, 7000, 7500, 7700	6914	6	Neg	Yes	\$33.99	RT-A-10	\$39.99	RT-A-H-10	\$44.99	RT-A-T-10
	3850 smaller (1/64") radius	6918	3	Pos	Yes	49.99	RT-3AS-10	57.99	RT-3AS-H-10	67.99	RT-3AS-T-10
	larger (1/32") radius	7681	3	Pos	Yes	49.99	RT-3A-10	57.99	RT-3A-H-10	67.99	RT-3A-T-10
Twin Cutters:	6900,6950 negative rake (std.)	6914	6	Neg	Yes	33.99	RT-A-10	39.99	RT-A-H-10	44.99	RT-A-T-10
	positive rake (standard) 1/64" (finer finish)	6918	3	Pos	Yes	49.99	RT-3AS-10	57.99	RT-3AS-H-10	67.99	RT-3AS-T-10
	positive rake (modified) 1/32" (more durable)	7681	3	Pos	Yes	49.99	RT-3A-10	57.99	RT-3A-H-10	67.99	RT-3A-T-10
	7900	6914	6	Neg	Yes	33.99	RT-A-10	39.99	RT-A-H-10	44.99	RT-A-T-10
Ammco HD	5000, 6000, 6002	5677	3	Pos	No	124.99	RT-373-10	---	---	---	---
Accu-Turn	All combination disc/drum lathes	433796	3	Pos	Yes	54.99	RT-AC-10	55.99	RT-AC-H-10	57.99	RT-AC-T-10
	On-The-Car Lathes	878051	6	Neg	Yes	33.99	RT-A-10	39.99	RT-A-H-10	44.99	RT-A-T-10
All-Tool	747	3331	6	Neg	Yes	33.99	RT-A-10	39.99	RT-A-H-10	44.99	RT-A-T-10
Bean	B-401, B-410, B-501, B-601	90487	3	Pos	Yes	44.99	RT-FMC-10	57.99	RT-FMC-H-10	67.99	RT-FMC-T-10
Bear	1410,1466,1467,1468, 1469, 1478	2264,72265,772834	6	Neg	Yes	34.99	RT-B-10	---	---	---	---
	10-1430, 10-1435	W136	6	Neg	No	107.99	RT-HF-10	---	---	---	---
FMC	600, 601, 700, 701, RotoTruer	90487	3	Pos	Yes	44.99	RT-FMC-10	57.99	RT-FMC-H-10	67.99	RT-FMC-T-10
	505, On-The-Car Lathe	91212	3	Pos	Yes	44.99	RT-KW-10	51.99	RT-KW-H-10	57.99	RT-KW-T-10
Hoffman	660	3331	6	Neg	Yes	33.99	RT-A-10	39.99	RT-A-H-10	44.99	RT-A-T-10
Hunter	BL300 On-The-Car Lathe	221580-2	6	Neg	Yes	33.99	RT-A-10	39.99	RT-A-H-10	44.99	RT-A-T-10
	BL-500, BL-501, BL-505	6918	3	Pos	Yes	49.99	RT-3AS-10	57.99	RT-3AS-H-10	67.99	RT-3AS-T-10
	BL-500	221-678-3	3	Pos	Yes	57.99	RT-HNT-10	---	---	---	---
Kwik-Way	CBL, NCL, SDL Kwik-Lathe OTC Lathe	109-1092-23	3	Pos	Yes	44.99	RT-KW-10	51.99	RT-KW-H-10	57.99	RT-KW-T-10
	Lightening Lathe	109-1092-45	3	Pos	Yes	---	---	---	---	91.99	RT-KWL-T-10
Performance	6600,7200,7100, 7600	3331	6	Neg	Yes	33.99	RT-A-10	39.99	RT-A-H-10	44.99	RT-A-T-10
Pro-Cut	On-The-Car Lathe	50-701, 50-742	3	Pos	Yes	44.99	RT-VBG-10	49.99	RT-VBG-H-10	57.99	RT-VBG-T-10
RJ West	915D Disc Lathes	W136	6	Neg	No	107.99	RT-HF-10	---	---	---	---
	Perfect 400, 1115HD	W139	3	Pos	Yes	54.99	RT-AC-10	55.99	RT-AC-H-10	57.99	RT-AC-T-10
RTI	BRC35 On-The-Car Lathe	91212	3	Pos	Yes	49.99	RT-3A-10	57.99	RT-3A-H-10	67.99	RT-3A-T-10
Snap-On	YA282,YA277,YA278, YA180 OTC Lathe	109-1092-23	3	Pos	Yes	44.99	RT-KW-10	51.99	RT-KW-H-10	57.99	RT-KW-T-10
Van Norman and Rels	204, 204D, 205, 205DC, 415, 243XV	29687	3	Pos	No	57.99	RT-VN-10	61.99	RT-VN-H-10	67.99	RT-VN-T-10
	Smaller (1/64") radius	---	3	Pos	No	51.99	RT-VNS-10	---	---	---	---
	204, 304, 405	29005	6	Neg	No	84.99	RT-VNA-10	---	---	---	---
	303,304,305,404,405,V22	304-7167	2	Pos	No	104.99	RT-VNP-L-10	---	---	---	---
VBG	204,205,205DR,300,302,333,243,243XV	302-7167	2	Pos	No	104.99	RT-VNP-R-10	---	---	114.99	RT-VNP-RT-10
	Rels 2000 rotor	45016, 45021	3	Pos	Yes	68.99	RT-RL-10	---	---	---	---
	On-The-Car Lathe	50-701	3	Pos	Yes	44.99	RT-VBG-10	49.99	RT-VBG-H-10	57.99	RT-VBG-T-10
Round Tips With Hole	Fits TAM-312 and TFM-312 Holders	RT-312,RT-312T	360°	Pos	Yes	179.99	RT-312-10	---	---	199.99	RT-312T-10
	Fits TAM-360SET, TFM-360SET, RJH and CT Holders	CT10	360°	Pos	No	48.99	RT-360-10	---	---	---	---

NOTE: The table above shows the original-equipment cutting tips for Ammco machines. Most of them use negative-rake tool systems. However, some Ammco machines (especially the 4000 and 7000-series) have been modified in the field by using the TAM-25968 and TAM-25969 positive-rake tool holders (see next page). If your machine is shown above to have 6-edge tips but has 3-edge tips, it has been modified – please order our RT-3A or RT-3AS series tips.

CYLINDER HEAD REBUILDING
CLEANING, ASSEMBLY & SAFETY
SHORT BLOCK REBUILDING
FLYWHEEL GRINDING
CRANKSHAFT/ TOOLS & SUPPLIES
MISCELLANEOUS
BRAKE SERVICE TOOLING
MEASURING TOOLS
V-TWIN & METRIC HARD PARTS



"If you need engine building tools and supplies, you need Goodson! We're dedicated to providing you with the best quality products, the best value and the best service in the industry."

- Mike, Goodson Purchasing - 5 years of service

CYLINDER HEAD
REBUILDING



Tip Holder for Drums

Fits **Ammco** 1000, 2002, 3000, 4000, 4100, 7500 & 7700; **All Tool** 747; **Hoffman** 660; **Performance** 6600, 7200, 7100 & 7600
Dimensions: $\frac{1}{2}$ " x $\frac{3}{8}$ " x $2\frac{1}{4}$ "
Replaces OE No. 9872
Orientation: Right
Use Tips: RT-A Series (includes 1)
Order No. **TAM-41R** Jobber \$22.99

CLEANING,
ASSEMBLY & SAFETY



Tip Holder for Rotors

Fits **Ammco** 3000, 3850, 4000, 4100, 7000 & 6900, 6950 Twin Cutters; **All Tool** 747; **Performance** 6600, 7200, 7100, 7600; **Hoffman** 660
Dimensions: $\frac{3}{8}$ " x $\frac{3}{8}$ " x $1\frac{1}{8}$ "
Replaces OE No. 10701, 10702
Use Tips: RT-A Series (includes 1)
Left: Order No. **TAM-702** Jobber \$22.99
Right: Order No. **TAM-701** Jobber \$22.99



Tip Holder for Rotors

Fits **Ammco** 3000, 3850, 4000 4100, 7000 & 6900, 6950 Twin Cutters
Dimensions: $\frac{3}{8}$ " x $\frac{3}{8}$ " x $1\frac{1}{8}$ "
Replaces OE No. 25968, 25969
Use Tips: RT-3A or RT-3AS (includes 1)
Left: Order No. **TAM-25969** Jobber \$29.99
Right: Order No. **TAM-25968** Jobber \$29.99

SHORT BLOCK
REBUILDING



Tip Holder for Drums & Rotors

Fits **Kwik-Way** CBL, NCL, SDL; **Snap-On** Y282, Y277, Y278, 180
Dimensions: $\frac{3}{8}$ " x $\frac{3}{8}$ " x $2\frac{1}{2}$ "
Replaces OE No. 109-1091-02, 109-1091-00
Use Tips: RT-KW Series (includes 1)
Left: Order No. **TKW-85L** Jobber \$24.99
Right: Order No. **TKW-84R** Jobber \$24.99

CRANKSHAFT/
FLYWHEEL GRINDING



Tip Holder for Curved Rotors With Flange

Fits **Accu-Turn**, **FMC**, **Ammco** & **Kwik-Way**
Dimensions: $\frac{3}{8}$ " x $\frac{3}{8}$ " x 3"
Replaces OE No. 434056, 434057
Use Tips: RT-B Series (includes 1)
Left: Order No. **TFO-42L** Jobber \$24.99
Right: Order No. **TFO-42R** Jobber \$24.99



Tip Holder for Round Tips With Hole

Fits **Accu-Turn**, **FMC**, **Bear**, **Hoffman**, **Kwik-Way**, **Snap-On**
Dimensions: $\frac{3}{8}$ " x $\frac{3}{8}$ " x $2\frac{3}{4}$ "
Use Tips: RT-312 Series (includes 1)
Left: Order No. **TFM-312L** Jobber \$29.99
Right: Order No. **TFM-312R** Jobber \$29.99

MISCELLANEOUS
TOOLS & SUPPLIES



Brazed Carbide Brake Lathe Tools

• Fit most popular brake drum lathes

Left Hand Cutting Tools

Size	Application	Jobber	Order No.
$\frac{3}{8}$ " sq. x $2\frac{1}{2}$ "	Replaces Bean 43-46L; Bear 23211; Star CB-8; VN 302-7272 for 303, 304, 304H	\$12.99	L-1
$\frac{5}{8}$ " sq. x 4"	Replaces Ammco 5725, for 5000; Star CB-30; VN "Big Brute" for 310-404 Hardspots	21.99	L-1A
$\frac{3}{8}$ " sq. x $3\frac{1}{2}$ "	Extra long L-1 for small dia. drums	12.99	L-1L
$\frac{3}{8}$ " sq. x $2\frac{1}{2}$ "	Master carbide-tipped with 7° rake angle	16.99	L-1S

Right Hand Cutting Tools

Size	Application	Jobber	Order No.
$\frac{3}{8}$ " sq. x $2\frac{1}{2}$ "	Replaces Bean 43-46R; Bear 20718; Star LB-16; VN 302-7171 for 204, 300, 302, 302H, 333, 243XV; and Barrett & Lemppo	\$12.99	R-1
$\frac{3}{8}$ " sq. x $2\frac{1}{2}$ "	Master carbide-tipped with 7° rake angle	9.99	R-1S
$\frac{5}{8}$ " sq. x 4"	Replaces Bear 24034, Star CB-35	21.99	R-4

Hardspot Cutters

Left Hand

Size	Use	Jobber	Order No.
$\frac{3}{8}$ " x $\frac{1}{2}$ " x $2\frac{3}{8}$ "	Drums	\$17.99	L-5

Right Hand

Size	Use	Jobber	Order No.
$\frac{3}{8}$ " x $\frac{1}{2}$ " x $2\frac{3}{8}$ "	Drums	\$17.99	R-5



L-5 R-5

BRAKE SERVICE
TOOLING

MEASURING
TOOLS

V-TWIN & METRIC
HARD PARTS

Carbide Cutting Tip Measurements

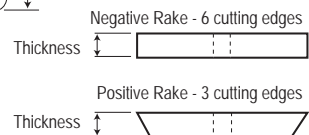
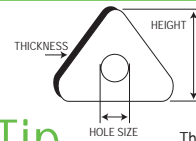

RT-A	RT-AC	RT-VBG	RT-VNS	RT-VNP-L / -R
Height: .350"	Height: .445"	Height: .344"	Height: .547"	Height: .902"
Thick: .095"	Thick: .131"	Thick: .098"	Thick: .121"	Thick: .100"
Hole: .135"	Hole: .145"	Hole: .124"	Hole: N/A	Hole: N/A
Rake: NEG	Rake: POS	Rake: POS	Rake: POS	Rake: POS

RT-3AS	RT-HF	RT-VN	RT-VNA	RT-312
Height: .357"	Height: .714"	Height: .545"	Height: .535"	Diameter: .311"
Thick: .104"	Thick: .185"	Thick: .125"	Thick: .188"	Thick: .100"
Hole: .127"	Hole: .200"	Hole: N/A	Hole: .148"	Hole: .150"
Rake: POS	Rake: NEG	Rake: POS	Rake: NEG	Rake: POS

RT-3A	RT-KW	RT-FMC	RT-KWL-T	RT-360
Height: .343"	Height: .358"	Height: .452"	Height: .338"	Diameter: .311"
Thick: .093"	Thick: .101"	Thick: .125"	Thick: .100"	Thick: .100"
Hole: .133"	Hole: .125"	Hole: .090"	Hole: .123"	Hole: N/A
Rake: POS	Rake: POS	Rake: POS	Rake: POS	Rake: POS

RT-373	RT-HNT	RT-B	RT-RL
Height: .625"	Height: .312"	Height: .343"	Height: .421"
Thick: .125"	Thick: .103"	Thick: .105"	Thick: .130"
Hole: .117"	Hole: .127"	Hole: .130"	Hole: .147"
Rake: POS	Rake: POS	Rake: NEG	Rake: POS

Brake Lathe Silencers



Neoprene Brake Lathe Silencer

- Longer lasting than rubber
- Neoprene material resists deterioration associated with standard rubber belts
- 7 sound deadening weights
- Measures: 34" L x 5/8" W x 3/16" Thick
- Order No. **GT-6030N** Jobber \$23.99



Rubber Brake Lathe Silencers

- Live rubber strap with 7 sound deadening weights • For vented rotors

Size	Jobber	Order No.
34"L x 5/8"W x 3/16" Thick	\$23.99	CE-8
36"L x 1 1/4"W x 3/16" Thick	46.99	CE-6930



Spring Silencer For Vented Rotors

- For 6" to 9" rotors
- Metal spring with internal sound dampeners
- Order No. **CE-13** Jobber \$31.99



Rubber Brake Lathe Tube Silencers for Vented Rotors

- 9/16" OD rubber tube with internal sound dampeners
- 2 sizes to choose from

Diameter	Weights	Jobber	Order No.
9"	6	\$26.99	CE-5
8"	4	26.99	CE-5S



Magnetic Strap Brake Lathe Silencer for Non-Vented Rotors

- Measures 48"L x 1/4" wide
- Eliminates silencer wandering on solid, non-vented rotors
- Order No. **CE-10** Jobber \$11.99

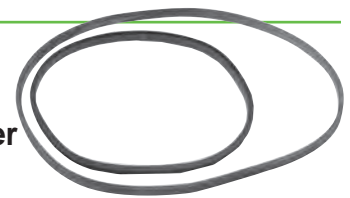

Rubber Band Brake Lathe Silencers for Non-Vented Rotors

- Neoprene rubber gasket type bands for thin solid rotors • Both sizes are 5/16" wide x 3/16" thick

Diameter	Jobber	Order No.
6 1/2"	\$6.99	CE-11
9 1/4"	6.99	CE-12



Rubber Tube Brake Lathe Silencer for Non-Vented Rotors

- For 6" to 9" solid rotors
- Order No. **CE-7** Jobber \$8.99



Chain Band Brake Lathe Silencer for Non-Vented Rotors

- For 6" to 9" solid rotors
- Order No. **GT-9802** Jobber \$66.99



Replacement Pucks for Ammco Friction Rotor Silencer

- Heavy non-asbestos pucks provide the mass needed to dampen vibration
- Sold as a pair
- Fits Ammco 7075 silencer
- Order No. **CE-9** Jobber \$24.99



Clamp-On Brake Lathe Silencers For Vented & Non-Vented Rotors

- Follows the cut to absorb vibrations where they start
- Outlast plastic pads, rubber straps and bands

Application	Jobber	Order No.
For Bench Model Brake Lathes	\$31.99	CE-6
For On-The-Car Brake Lathes	30.99	CE-26

Premium Rubber Brake Lathe Silencers for Brake Drums

- Premium live rubber straps
- Two sizes to choose from

Application	Size	Jobber	Order No.
Passenger Cars	62"L x 2 7/8"W x 1/8" Thick	\$20.99	CE-1
Trucks	78"L x 2 7/8"W x 1/8" Thick	35.99	CE-2



CYLINDER HEAD REBUILDING
CLEANING, ASSEMBLY & SAFETY
SHORT BLOCK REBUILDING
CRANKSHAFT/FLYWHEEL GRINDING
MISCELLANEOUS TOOLS & SUPPLIES
BRAKE SERVICE TOOLING
MEASURING TOOLS
V-TWIN & METRIC HARD PARTS



Replacement Work Light

- 30" adjustable arm
- 5/8" round mounting end
- Uses up to 100W standard base bulb (not included)
- Easily accessible switch
- Fits most Ammco models
- Order No. **GT-7963**
Jobber \$99.99



Replacement Switch for Ammco Brake Lathes

- Easy to install
- Fits most models
- Order No. **GT-7893**
Jobber \$14.99

1" Arbor for Ammco

- Fits Ammco 2002, 3000, 4000, 4100, 7000, 7500 & 7700 models
- 7/8" x 9 LH thread
- Precision ground
- Factory checked for run-out of less than .001" • Heat treated, stress relieved tool steel • For drums & rotors up to 125 lbs.
- Order No. **GT-3101**
Jobber \$224.99



1HP Motor for Ammco Brake Lathes

- Fits 3000, 4000, 4100, 7000, 7500, & 7700 models
- 208 / 230 / 115V • 60Hz
- 1725 RPM • Shaft: .625"
- Includes motor plate and all accessories in photo
- Order No. **GT-2165**
Jobber \$529.99

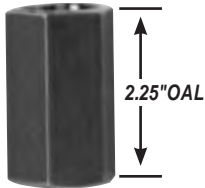

1" Arbor Nut For Ammco

- 7/8" x 9 Left Hand Thread
- Fits Ammco 2002, 3000, 4000, 4100, 7000, 7700 and 3850 models
- Order No. **GT-3102**
Jobber \$31.99



1" Arbor Nut For All But Ammco

- 1" x 9 Left Hand Thread
- Fits AccuTurn 433701, All Tool 747, FMC 601, 701 & 702, Hunter, Van Norman/Rels 204, 243
- Order No. **GT-20442N**
Jobber \$25.99

Brake Lathe Centering Spring

- Fits any 1" arbor brake lathe
- 1.687" ID
- 1.927" OD
- 4.000" OAL
- Order No. **GT-3110**
Jobber \$5.99



Mounting Spacers

Length	Jobber	Order No.
1/2"	\$ 5.99	GT-3125
Flexible	45.99	GT-9492



enlarged to show detail

Brass Wear Inserts For Ammco

Di. x Lgth.	Jobber	Order No.
3/16" x 1/8"	\$2.49	GT-3141
1/8" x 1/4"	2.49	GT-3142
(most popular)		
1/4" x 1/8"	2.49	GT-9836



Replacement Seals For Ammco

Application	OD	Jobber	Order No.
Feed Screw	1.25"	\$9.49	3163
Spindle	3.55"	9.99	3164

Replacement Screw for Twin Cutter Tool Bit Holders

- Square Head Screw
- Order No. **GT-9249**
Jobber \$2.49

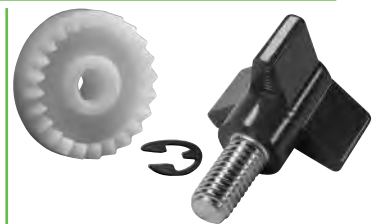

Small Ammco Replacement Parts

Description	Jobber	Order No.
Locking Knob	\$4.49	6854
Cross Feed Shear Gear with C-Clip	6.49	7996



Ammco Rotor & Drum Feed Screw Bushings

Description	Jobber	Order No.
Rotor Feed Bushing (early)	\$34.99	GT-10868
Rotor Feed Bushing (late)	32.99	GT-10868X
Drum Feed Bushing (all)	63.99	GT-4670
Lead Screw Bushing Adaptor	32.99	LSB-78529



Tooling Hold Down Pieces For Ammco

Description	Jobber	Order No.	Incl.
Stud Assembly	\$37.99	GT-25900	▼
6 1/2" Stud	11.49	GT-25913	x
Nut Assembly (must be used with 6 1/2" Stud)	26.99	GT-11227	x

Brake Conditioning Spray

- Spray on rotors and drums to stop noise at the source
- OE approved spray-on metalizing treatment
- Effective from -100°F to +2000°F
- Prevents rust and seizure of lug nuts and threads
- Over spray won't damage calipers, rubber components or seals
- Aerosol*
- Order No. **BS-12***
Jobber 1+ \$19.99 ea., 12+ \$17.99 ea.



* Hazardous Fees Apply When Shipped By Air

Pastelub™ Synthetic High Temp Brake Lubricant

- OE recommended • High pressure resistant • Recommended for the backs of brake pads
- Not for use on friction surfaces
- 2400°F Ultra high-temperatures range
- Patented "real synthetic" Swiss formula won't melt, rub or wash off brake parts
- Gray • No silicone or petroleum to weaken the carrier base
- Order No. **BPL-2400**
1+ Jobber \$19.99 ea.
12+ Jobber \$17.99 ea.



Ceramlub-2800™ Extreme High Temperature Lubricant

- Use on brake caliper slides, etc.
- Contains ceramic pressure solids and high concentrations of anti-corrosive agents
- Specifically designed for use on caliper slides, rubber seals & O-Rings
- A great complement to Pastelub™ Hi-Temp Lubricant
- Purple • Order No. **CBL-2800**
1+ Jobber \$19.99 ea.
12+ Jobber \$17.99 ea.



Buy a case of 12 (any combination BS-12, BPL-2400, CBL-2800), SAVE 10% off jobber

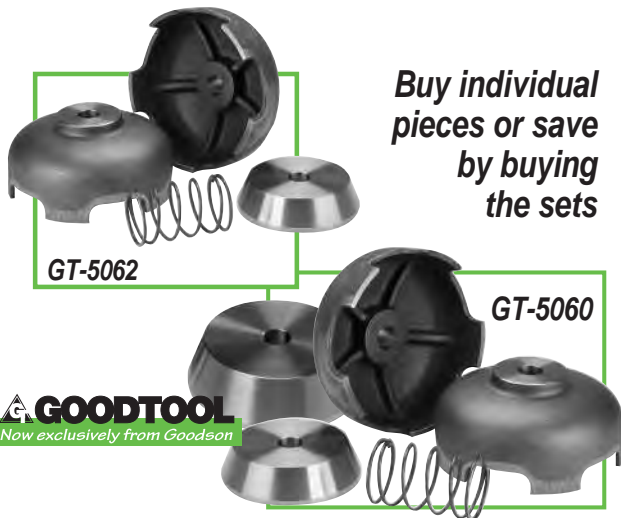

Buy individual pieces or save by buying the sets

GOODTOOL
Now exclusively from Goodson

Truck Mounting Adaptor Sets For Brake Lathes With 1" Arbors

Description	Jobber	Order No.	Incl.
Standard Truck Set	\$329.99	GT-5062	▼
Master Truck Set	459.99	GT-5060	▼
Centering Cones			
3.750" x 5.125"	114.99	GT-5053	1 1
4.500" x 5.500"	91.99	GT-5052	
5.000" x 6.125"	118.99	GT-5054	1
Bell Clamps			
6.500" OD	119.99	GT-5055	1 2
7.750" OD	159.99	GT-5056	1
Heavy-duty Spring	2.515" OD x 2.217" ID x 4" L	17.99	GT-5059 1 1

Automotive Brake Lathe Bell Clamps

OD Size: 4.500"	OD Size: 5.700"
Arbor Size: 1.000"	Arbor Size: 1.000"
Order No.: GT-9490	Order No.: GT-3123
Jobber: \$43.99	Jobber: \$75.99



Brake Drum Grinding Wheels

- Aluminum-Oxide abrasive

For Van Norman / Rels 204, 300, 302, 303, 333 & 404 Drum Grinders

Size	OE No.	Shape	Jobber	Order No.
3" x 1/2" x 1"	8522	Recessed	\$19.99	GDV-304
3 1/2" x 1/2" x 1"	8931	Recessed	32.99	GDV-354

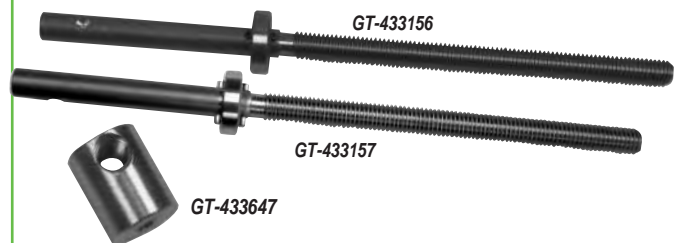

Assorted Accu-Turn Replacement Parts

Description	Jobber	Order No.
Rotor Feed Screw Assembly (1/2" 20TPI)	\$71.99	GT-433156
Drum Feed Screw Assembly (1/2" 13TPI)	71.99	GT-433157
Rotor Feed Bushing (fine thread)	35.99	GT-433647
Drum Feed Bushing (not shown) (coarse thread)	51.99	GT-433646

When using bell clamps and centering cones always be sure they are clean and free of any dirt or rust. Keep a light coating of oil on them to prevent rusting.

Never use a cone or a bell clamp for anything other than mounting a brake rotor or drum onto the brake lathe. Always use the largest bell clamp that will fit the rotor or drum for the best support.

tech tips
from the techxperts™

CYLINDER HEAD
REBUILDING
CLEANING,
ASSEMBLY & SAFETY
SHORT BLOCK
REBUILDING
FLYWHEEL GRINDING
CRANKSHAFT/
MISCELLANEOUS
TOOLS & SUPPLIES
BRAKE SERVICE
TOOLING
MEASURING
TOOLS
V-TWIN & METRIC
HARD PARTS



"We pride ourselves on packaging our products carefully and professionally. We want you to receive your order quickly and in good condition."

- Brian, Goodson Receiving, 31 years of service



CYLINDER HEAD REBUILDING
CLEANING, ASSEMBLY & SAFETY
SHORT BLOCK REBUILDING
CRANKSHAFT/ FLYWHEEL GRINDING
MISCELLANEOUS TOOLS & SUPPLIES
BRAKE SERVICE TOOLING
MEASURING TOOLS
V-TWIN & METRIC HARD PARTS

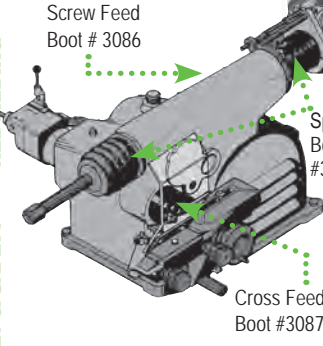

tech tips
from the techexperts™
Rubber is the standard boot material on most brake lathes



Replacement Boot Packs

- Keep extra boots on hand for routine maintenance or emergency replacement
- Fits Ammco 3000, 4000, 4100, 7000, 7700

Description	Jobber	Order No.	Incl.
Rubber Boot Pack	\$86.99	RSB-BOOT-PK	▼
Rubber Spindle Boot Kit	53.99	RSB-KIT	▼
Rubber Spindle Boot	25.49	RSB-3085	x x
Neoprene Spindle Boot	22.99	3085	
Screw Feed Dust Boot	19.99	3086	x
Cross Feed Dust Boot	17.99	3087	x
Boot Ring	25.99	23682	x x
C-Clip	3.49	SBR-4435	x x
Snap Ring	5.99	SBR-3159	x x

Drive Pulleys & Belts for Ammco

- Fit Ammco 3000, 4000, 4100, 7000 & 7100
- Serpentine design runs quieter and increases arbor speed by 175RPMs • Virtually eliminates vibration

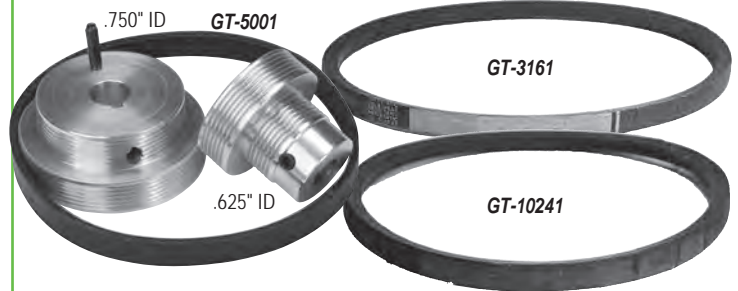

New-Style (Serpentine)

Description	Jobber	Order No.
Pulley Set (Includes 20 1/4" belt & 2 pulleys)	\$189.99	GT-5001
20 1/4" Belt	21.99	GT-5002
19" Belt	21.99	GT-5003

Original-Style (V-belt) Replacements

Description	Jobber	Order No.
25" Belt (replaces OE 3161)	\$11.99	GT-3161
24" Belt (replaces OE 10241)	13.49	GT-10241



Install the drive pulley with the pin toward the right angle drive. The roll-pins drive against each other. A nylon sleeve prevents metal to metal contact.

Don't buy a new brake lathe ... expand your existing one to handle rotors up to 15"

Lead Screw Bushing

- Easy installation
- Increases lathe capacity to 15"
- Ideal for machining large rotors common on SUVs and large pick-ups
- Fits Ammco 3000 and 4000 Brake Lathes
- Order No. **LSB-78529** Jobber \$32.99



See page 85 for more Flex-Hones®

Brake Rotor Flex-Hones®

- Provide a non-directional finish
- Use with a 3/8" variable speed drill at 600-1000 RPM
- Zirconium abrasive
- Use dry

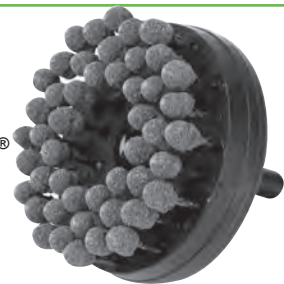

Type	Grit	Jobber 1+	Jobber 3+	Order No.
Fine	240	\$56.99	\$51.29	BRF-25F
Medium	120	56.99	51.29	BRF-25M
Coarse	60	56.99	51.29	BRF-25C

Order 3 or more Flex-Hones® (any combination) to Save 10% off Jobber!

Carbide Tipped Brake Drum Swedge Cutting Tool

- Hard-to-find tool cuts wheel stud swedges to remove and replace pressed-in wheel studs
- Use with a drill press or mill
- For 1/2" stud
- Order No. **ST-500** Jobber \$104.99

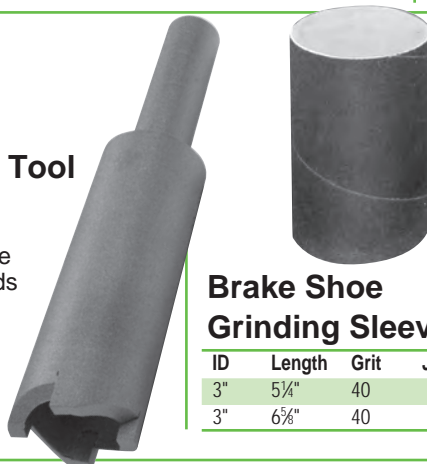

Brake Shoe Grinding Sleeves

ID	Length	Grit	Jobber	Order No.
3"	5 1/4"	40	\$6.49	AS-2
3"	6 5/8"	40	7.49	AS-4



Rotor Feed Screws & Nuts For FMC & Bean

Description	Jobber	Order No.
Rotor Feed Screw	\$57.99	GT-90071
Rotor Feed Nut	57.99	GT-90077



Precision Straight Edges

- 2 sizes to choose from
- Accuracy .0005" per foot
- Precision ground one edge
- .375" thick high quality heat-treated steel construction
- Each straight edge is pre-drilled for easy wall storage

Description	Jobber	Order No.
24" straightedge, 1 precision edge	\$144.99	DIS-24
36" straightedge, 1 precision edge	229.99	DIS-36



Rod Bolt Stretch Gauge

- Accurate to .001"
- Features a 1½" dial gauge
- Extra heavy-duty tension spring for repeatable accuracy
- For bolts from 1" to 2½" long

Description	Jobber	Order No.
Rod Bolt Stretch Gauge	\$86.99	RBSG-3
Optional Contact Point	12.99	ERBG-3T
Replacement Pointer	9.99	RBSG-P

tech tips
from the techxperts™

Most engine rod failures aren't from faulty parts, they're from improper installation. When you're installing connecting rods, you need to

check the rod bolt stretch by performing a series of torquing and loosening and recording the readings.

Here's how:

1. Torque the bolts to 15 foot pounds and measure the stretch. Record the reading, then loosen the bolts.
2. Repeat at 15 foot pounds and record the reading.
3. Repeat, increasing to 30 foot pounds, record the reading.
4. Repeat, increasing to 60 foot pounds, record the reading.
5. Repeat at 60 foot pounds and record the reading.

Each time you loosen the bolts, measure to be sure that the rod bolts have returned to within .001" of the starting size. If you have a greater variation, get rid of the rod bolts and start with new ones.

When you're conducting final assembly, be sure you use the stretch specified by your rod manufacturer. Attach a rod bolt stretch gauge to the connecting rod bolt and zero it. Use an extra-long box wrench to tighten until the proper stretch is achieved.



Small Hole Gauge Set

- See if rebuilding or replacement is needed by checking actual guide wear
- Check guide bosses for proper interference fit during replacement
- Check and maintain correct stem to guide ID clearance
- 4-piece set has combined range of .125"-.500" / 3.2-12.7mm
- Storage case included
- Order No. **SHG-5** Jobber \$149.99

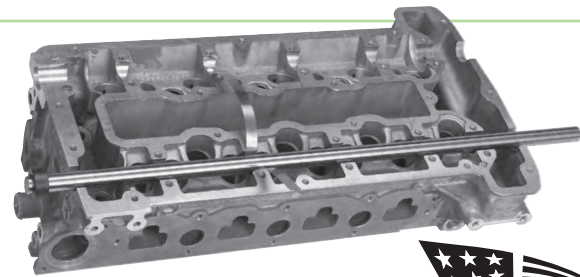

26" Round Warp Gauge

- Use with feeler gauges (below)
- ¾" diameter tool steel
- Includes anti-roll collar and eye bolt allowing you to hang it for safe, convenient storage
- Order No. **EWG-100** Jobber \$172.99



12" Feeler Gauges

- Measure piston-to-wall clearance when honing, to find ring end gap and to check cylinder heads with a straight-edge
- Also useful for shimming while straightening heads and for machine set-ups

	Jobber	Order No.	
Complete Kit	\$44.99	FE-KIT	▼
Thick .0015"	4.99	FE-0015	x
.0020"	4.99	FE-002	x
.0030"	4.99	FE-003	x
.0040"	4.99	FE-004	x
.0050"	4.99	FE-005	x
.0060"	4.99	FE-006	x
.0070"	4.99	FE-007	x
.0080"	4.99	FE-008	x
.0090"	4.99	FE-009	x
.0100"	4.99	FE-010	x
.0150"	4.99	FE-015	x
.0200"	4.99	FE-020	x



Split Ball Bore Gauge

- Dial gauge with large contact area
- Measures quickly & accurately to .0001"
- Works in threaded or knurled guide IDs
- Range: .280"-.400" • Easy to change contacts
- Order No. **MVG-34** Jobber \$699.99



6 Piece Telescoping Gauge Set

- Compress spring plunger and lock by twisting handle
- Insert into bore and release plunger – it will expand to fit
 - Lock again and remove
 - Measure with a micrometer
 - Double plunger design for consistent measuring
 - Long-lasting finish
 - Size range: ¾" - 6"
- Order No. **MTG-6** Jobber \$139.99



CYLINDER HEAD REBUILDING
CLEANING, ASSEMBLY & SAFETY
SHORT BLOCK REBUILDING
CRANKSHAFT/ FLYWHEEL GRINDING
MISCELLANEOUS TOOLS & SUPPLIES
BRAKE SERVICE TOOLING
MEASURING TOOLS
V-TWIN & METRIC HARD PARTS

full service
...fast



"From the time we answer the phone to when you receive your delivery, our goal is to get it right the first time and every time."
- Paige, Goodson Customer Service, 4 years of service



Build Your Own Valve Guide Gauge Set! Order the Valve Guide Gauge (P-300), Setting Fixture (P-610A) and the Valve Guide Probe you need.



Valve Guide Gauge Set

- The only way to be sure clearance is correct is to gauge it
- Checks all types of guides for size and roundness FAST
- Set up and measure valve guide IDs quickly and easily
- Complete set includes gauge, 3 probes (.312", .344" and .375"), hex wrench, setting fixture and metal storage case with spaces for all components
- Dial calibrated in .0002" increments

Description	Jobber	Order No.	Incl.
Complete Valve Guide Gauge Set	\$2534.82	P-310	▼
Valve Guide Gauge	785.93	P-300	x
Setting Fixture	690.99	P-610A	x
Valve Guide Probes			
Size	Range in.	mm	
.236"	.244" to .264"	5.69 to 6.71	\$437.25 P-236
.250"	.238" to .278"	6.05 to 7.05	453.15 P-250
.281"	.269" to .309"	6.83 to 7.85	470.60 P-281
.312"	.300" to .340"	7.62 to 8.64	486.44 P-312 x
.344"	.332" to .372"	8.43 to 9.45	502.34 P-344 x
.375"	.363" to .403"	9.22 to 10.24	479.79 P-375 x
.406"	.394" to .434"	10.01 to 11.02	535.48 P-406
.438"	.426" to .466"	10.82 to 11.84	551.00 P-438
.469"	.457" to .497"	11.61 to 12.62	567.16 P-469
.500"	.488" to .528"	12.40 to 13.41	584.66 P-500



Sunnen® AG-Series Precision Gauge

- Dial reads directly in "tenths" (.0001")
- Checks rod journal bore for distortion
- Measures size instantly
- Wear-compensated gauge points for permanent accuracy
- Rugged construction – all moving parts are enclosed in the housing
- Includes Point Sets listed below (optional point sets are available, call for information)



Description	Jobber	Order No.
.375" - 3.375" (9.5 - 85.7mm) Range Gauge	\$4999.99	AG-300
Standard Point Set (.720" - 1.530" Range)	72.46	AG-210
Medium Point Set (1.50" - 2.25" Range)	108.68	AG-620
Large Point Set (1.932" - 2.687" Range)	108.68	AG-630
Sun-Dura® Gauge Cover (8"L x 8"H x 4"D)	39.99	GMC-AG300

Point sets will NOT fit AG-gauges lower than Serial No. 4000



Distributor Depth Gauge

Working on a Big Block or Small Block Chevy with a distributor? Avoid problem wear and potential failure caused by a distributor that fits too deep. This easy to use gauge measures the depth of engagement allowing you to compensate to create adequate clearance. Kit comes complete with a .500" diameter adaptor. An optional .491" shaft is also available.

Description	Jobber	Order No.
Distributor Depth Gauge Kit	\$259.99	DDG-05
.491" Shaft	72.99	DDG-491

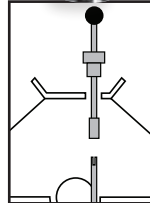

Fig. 1
Insert depth gauge in place of distributor. Bottom out in oil pump drive.

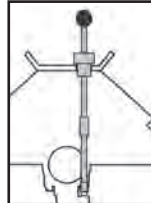

Fig. 2
Push down on the top collar, making top contact with manifold.

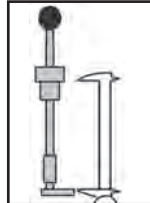

Fig. 3
Remove depth gauge from engine. Install adaptor in distributor tool. Measure and record depth.

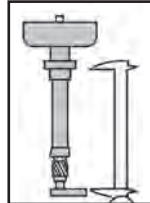

Fig. 4
Install adaptor in distributor drive. Measure as before and compare. Shim as needed to create clearance.

⚠ WARNING: Operating, servicing and maintaining a passenger vehicle or off-road vehicle can expose you to chemicals including engine exhaust, carbon monoxide, phthalates, and lead, which are known to the State of California to cause cancer and birth defects or other reproductive harm. To minimize exposure, avoid breathing exhaust, do not idle the engine except as necessary, service your vehicle in a well-ventilated area and wear gloves or wash your hands frequently when servicing your vehicle. For more information go to www.P65Warnings.ca.gov/products/passenger-vehicle.

CYLINDER HEAD REBUILDING
CLEANING, ASSEMBLY & SAFETY
SHORT BLOCK REBUILDING
CRANKSHAFT/ FLYWHEEL GRINDING
MISCELLANEOUS TOOLS & SUPPLIES
BRAKE SERVICE TOOLING
MEASURING TOOLS
V-TWIN & METRIC HARD PARTS

Sunnen® Dial Bore Gauges



Sunnen® Dial Bore Gauges

- Standard Sunnen® Dial Bore Gauges read out in tenths
- Also available in five-tenths and metric (special order)
- Diameter ranges from .495" to 6.000" (see chart for gauge ranges)
- All models below feature all-carbide gauging points, wear-proof ball crank and adjustable centralizers
- Include molded storage case with all tools and wrenches required for setup and adjustment

Shock-Shield protects dial from hand heat and jarring to assure accurate reliable readings.

All standard Sunnen Dial Bore Gauges are TENTH READING. Metric and .0005" readouts are also available (special order). Dial can be indexed 90° for easy reading at any angle.

Adjustable centralizers for proper centering over the entire diameter range. One twist adjusts gauge tension so head goes into and out of any size hole smoothly.

Patented wear-proof ball crank assures repeatability over a long life.

Carbide indicating points are long wearing and replaceable.

Transfer Rod

Indexable Centralizer Points

- GA-4141**
- Measures to within .200" of the bottom of a blind bore
 - Carbide balls replaceable in the indicating fingers only
 - Set with SCF-502 Setting Fixture
 - Non-retractable gauge

- GR-6241**
- Measures to within .270" of the bottom of a blind bore
 - Carbide balls replaceable in the indicating fingers only
 - Set with SCF-502 Setting Fixture
 - Retractable gauge

- GR-9241**
- Measures to within .335" of the bottom of a blind bore
 - Carbide balls replaceable in indicating fingers and extension points
 - Set with SCF-502 Setting Fixture
 - Retractable gauge

- GA-2121 / GA-2125 / GR-2121 / GR-2241 / GR-2245**
- Measures to within .500" of the bottom of a blind bore
 - Carbide balls replaceable in indicating fingers and extension points • Use CF-1126 Setting Fixture
 - Non-retractable gauge

Diameter Range		Max Gauging Depth		Overall Length		.0001" Reading		.0005" Reading	
in	mm	in	mm	in	mm	Jobber	Order No.	Jobber	Order No.
.495" to .750"	12.6 to 19.0	7.00"	175	11.8125"	302	\$1370.33	GA-4141	-----	-----
.740" to 1.19"	18.9 to 30.2	12.00"	300	17.6875"	451	1508.82	GR-6241	-----	-----
1.18" to 2.00"	30.0 to 50.8	12.00"	300	17.75"	452	1542.09	GR-9241	-----	-----
2.00" to 6.00"	50.0 to 150.0	12.00"	300	17.00"	432	1370.33	GA-2121	\$1370.33	GA-2125
2.00" to 6.00"	50.0 to 150.0	12.00"	300	17.00"	432	1632.73	GR-2121	-----	-----
2.00" to 6.00"	50.0 to 150.0	24.00"	600	29.00"	737	1574.42	GR-2241	1632.73	GR-2245

Small Diameter Dial Bore Gauge & Accessories

- Dial Bore Gauge assembly consists of .0001" (.002mm) reading indicator, probe retractor and probe retainer bushing in a reinforced nylon insulating shroud
- Dial Bore Gauge diameter range: 0.165" to 0.386" (4.191 to 9.804mm)

Description	Jobber	Order No.
1-Small Diameter Dial Bore Gauge	\$1159.75	GR-3000
2-Adjustable Probes	Range in mm	
	.165" to .189"	4.191 to 4.800 258.31 G-1180
	.185" to .209"	4.699 to 5.308 258.31 G-1200
	.205" to .228"	5.207 to 5.791 258.31 G-1220
	.224" to .248"	5.689 to 6.299 258.31 G-1240
	.244" to .268"	6.198 to 6.807 258.31 G-1260
	.264" to .287"	6.706 to 7.290 258.31 G-1280
	.283" to .307"	7.188 to 7.798 258.31 G-1300
	.303" to .327"	7.696 to 8.306 258.31 G-1320
	.323" to .346"	8.204 to 8.788 258.31 G-1340
	.343" to .366"	8.712 to 9.296 258.31 G-1360
	.362" to .386"	9.195 to 9.804 258.31 G-1380
3-Transfer Pin (fits all probes above)	182.29	G-2264
4-Probe Extension	219.25	KZIX-3500

How to Order:

1 - Gauge

2 - Probe

3 - Transfer Pin

4 - Probe Extension



Dial Bore Gauge Setting Fixtures

- Models combine to cover a continuous range of .054" to 8" in .0001" increments
- Heavy stress-relieved cast iron bases
- Lapped carbide micrometer anvils
- Built-in magnifier
- Each setting fixture includes a master calibrating ring
- Size Setting Adaptor centers gauge probes between parallel reference surfaces on SCF-502 Setting Fixture

Range	Jobber	Order No.
.054" to 2.00"	\$2663.07	SCF-502
Size Setting Adaptor	1199.51	CF-540
2.00" to 8.00"	2514.70	CF-1126

Gauges & Setting Fixtures Sold Separately

SCF-502 shown with GR-6241

CF-1126 shown with GR-2121

SCF-502 with CF-540 Size Setting Adaptor shown with GR-3000 Gauge



CYLINDER HEAD REBUILDING ASSEMBLY & SAFETY CLEANING SHORT BLOCK REBUILDING FLYWHEEL GRINDING TOOLS & SUPPLIES CRANKSHAFT/ MISCELLANEOUS BRAKE SERVICE TOOLING MEASURING TOOLS V-TWIN & METRIC HARD PARTS



Mitutoyo

Dial Bore Gauge Set

- Rugged bore gauge with protected dial
- Carbide tipped contact points
- .0001" (.001mm) graduations • Indication stability: .00008"
- Accuracy: .0002" • Shoe can be rotated for a fresh wear surface • Sets up with a standard micrometer (see page 130)

Range	Description	Jobber	Order No.
2.0"-6.0"	11 anvils and 4 spacers	\$594.99	MMCB-06
Replacement Spacers for anvils 2" & larger	.020"	10.99	MMCB-06-020
	.040"	10.99	MMCB-06-040
	.080"	10.99	MMCB-06-080
	.120"	10.99	MMCB-06-120
Replacement Lens		23.99	MMCB-06LENS
Replacement Dial Indicator		229.99	MMCB-06IND
Replacement Dial Cover		29.99	MMCB-06COVER



0.0005" Graduation Dial Bore Gauge

- Includes: .050" travel indicator, 3 spacers (.100", .050" and .020"), 11 anvils and storage case
- Use for precise bore measurements
- Bore depth: 6" • Range: 2" to 6"

Description	Jobber	Order No.
Dial Bore Gauge	\$189.99	EBG-265
11 Piece Replacement Spacer Set	42.99	EBG-ANVILS



Metric Dial Bore Gauge

- Carbide anvils
- Easy-to-read gauge
- Insulated grip with chrome plated handle
- Includes: extension holder and fitted case
- Range: 35 to 160mm
- Graduations : 0.01mm
- Order No. **MCBG-160** Jobber \$224.99



0.7" to 1.5" Range Cylinder Dial Bore Gauge Set

- Carbide anvils • Easy to read gauge
- Measure cylinders up to 9.5" deep
- Graduations: 0.0005" • Self-centering • Insulated grip
- Chrome plated handle • Includes extension holder and case • Order No. **FBG-7** Jobber \$169.99



Internal Electronic Caliper

- Ideal for measuring mating port runners and bowl diameters
- Hardened contact surfaces
- Robust housing with large LCD display
- Range: 0.5" to 6.0" • Reading: .01" (.3mm) / 1/64th
- Spring loaded locking nut
- Order No. **IEC-56** Jobber \$62.99



1.4" to 6" Range Cylinder Dial Bore Gauge Set

- Carbide anvils • Easy to read gauge
- Measure cylinders up to 9.5" deep • Graduations: 0.0005"
- Self-centering • Insulated grip • Chrome plated handle
- Includes extension holder and case
- Order No. **FBG-146** Jobber \$209.99

Mounts on Your Pilot



Valve Seat Height Gauge

Includes Dial Indicator

- Confirm seat height to fire deck location
- Adjusts for all popular seat diameters
- Accurate to .001"
- Seat contact probe aligns on valve seat while gauge rides along the fire deck
- Pilot aligns in valve guide (pilot sold separately)
- Adjustable to fit popular seat diameters from .750" to 3.00"

Description	Fits Pilot	Jobber	Order No.
Valve Seat Height Gauge Kit	.375"	\$102.99	VSHG-375
Replacement Dial Indicator		31.99	EDI-1

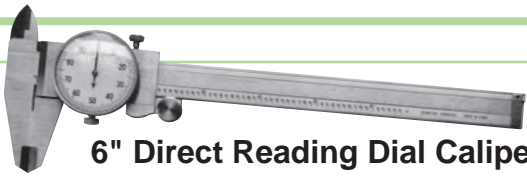

6" Direct Reading Dial Caliper

- Four way measurement - outside, inside, depth and step
- Hardened stainless steel with satin chrome finish
- Precision ground and lapped measuring surfaces
- Reads direct to .001" or with .100" graduations on beam
- Adjustable bezel with lock
- Thumb roll with lock
- 1 5/16" jaw length
- Large easy to read dial
- Covered rack • Deluxe fitted case
- Order No. **MDC-03** Jobber \$79.99



12" Direct Reading Dial Caliper

- .001" single revolution • Hardened measuring face
- Precision Ground • Micro-lapped for accuracy
- Adjusting slide for fine adjustment
- Take Inside, Outside and Depth measurements
- Satin Chrome finish with engraved graduations
- Clamp for repetitive readings
- Accurate to .001" per 6"
- Covered Rack • Deluxe fitted case
- Order No. **EDC-12** Jobber \$149.99

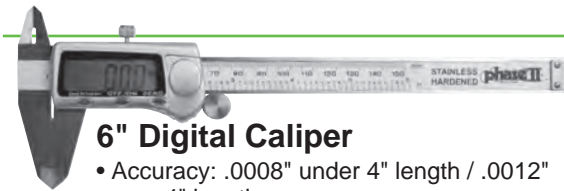

6" Digital Caliper

- Accuracy: .0008" under 4" length / .0012" over 4" length
- .0005" (.01mm) resolution
- Automatic floating zero
- Used to take Inside and Outside measurements
- Direct inch/metric Conversion
- Large, high-contrast LCD display
- On/Off Button • Deluxe fitted case

Description	Jobber	Order No.
Digital Caliper	\$68.99	EEDC-06
Replacement Battery	6.49	EDC-06B

Use with a one or more dial indicators

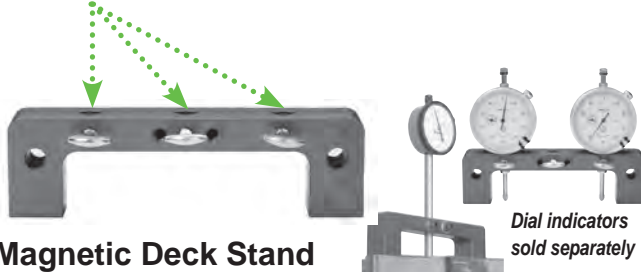

Magnetic Deck Stand

- Precision manufactured with 6 to 8 pounds of magnetic pull yet slides smoothly over the piston dome and deck
- Should only be used with dial indicators (sold separately) in upright position - perpendicular to the ground
- Order No. **MDBS-2** Jobber \$99.99

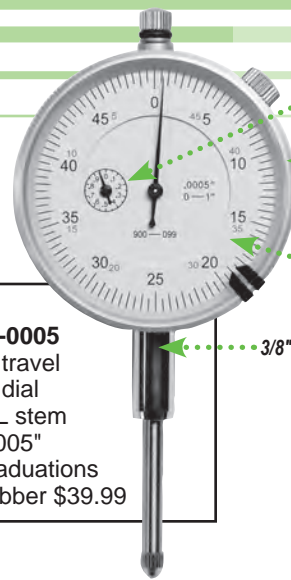

- EDI-0005**
- 1" travel
 - 2" dial
 - 1"L stem
 - .0005" graduations
 - Jobber \$39.99

Revolution Counter
(included on most models)

Adjustable bezel
for zero settings

Shatter resistant crystal

3/8" stem

All Indicators
have lug back



- EDI-1**
- 1" travel • 2" dial
 - 1"L stem
 - .001" graduations
 - Jobber \$31.99



- MDI-2**
- 2" travel • 3" dial
 - 2"L stem
 - .001" graduations
 - Jobber \$78.99

- MDI-12**
- .125" travel
 - 2" dial
 - 12"L stem
 - .001" graduations
 - Jobber \$449.99

Starrett
Goodson
EXCLUSIVE

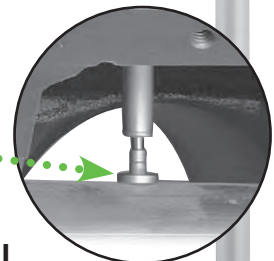

Dial Indicator Flat Anvil

- Use with dial indicator (sold separately) to make full contact on surface to be measured
- Especially useful when measuring deep inside blocks in combination with our magnetic deck stand (MDBS-2 at left)
- Order No. **MDI-12A** Jobber \$32.99

CYLINDER HEAD REBUILDING
CLEANING, ASSEMBLY & SAFETY
SHORT BLOCK REBUILDING
CRANKSHAFT/GRINDING TOOLS & SUPPLIES
MISCELLANEOUS TOOLS
BRAKE SERVICE TOOLS
MEASURING TOOLS
V-TWIN & METRIC HARD PARTS



Premium Micrometers

- Precision ground carbide anvil parallel to within .0001"
- .0001" graduations
- Set includes wood storage case

Description	Range	Jobber	Order No.	Incl.
Micrometer Set	(wood storage case)	\$329.99	EMS-06	▼
Individual Micrometers	0"-1" (no standard)	43.99	EMIC-01	x
	1"-2"	49.99	EMIC-12	x
Each Micrometer	2"-3"	55.99	EMIC-23	x
includes a Standard,	3"-4"	64.99	EMIC-34	x
Spanner Wrench & Case	4"-5"	77.99	EMIC-45	x
(except EMIC-01)	5"-6"	79.99	EMIC-56	x

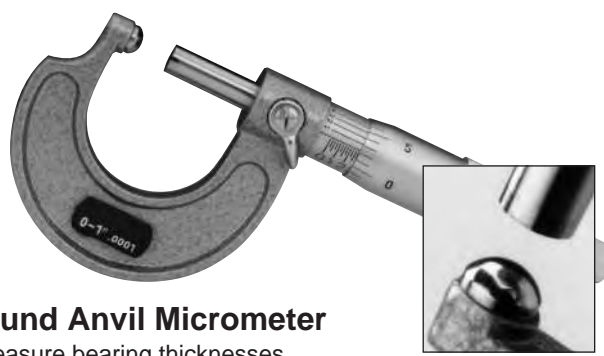

Round Anvil Micrometer

- Measure bearing thicknesses
- Ratchet spindle • 0-1" range • Precise to .0001"
- Order No **MIC-01-B** Jobber \$127.99

Checking Standards

- Use to set up dial indicators in special application gauging and to check micrometer accuracy
- Made of hardened, ground and lapped tool-steel
- Meet or exceed federal accuracy specifications



Length	Jobber	Order No.
1"	\$12.99	MCS-1
2"	13.99	MCS-2
3"	14.99	MCS-3

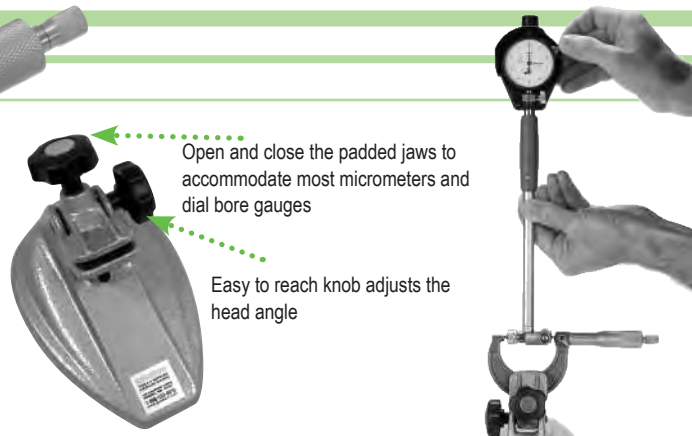

Open and close the padded jaws to accommodate most micrometers and dial bore gauges

Easy to reach knob adjusts the head angle

Micrometer Stand

- Heavy cast iron construction
- Use to hold micrometers, standards or just about anything you need an extra hand for
- Swivel head and padded jaws won't damage expensive measuring tools
- Order No. **MIC-FIX** Jobber \$24.99

Use a Micrometer Stand When Setting Your Dial Bore Gauge

Read more about it on our blog. Scan the code with your smart phone or other smart device for quick access.



MBR-1

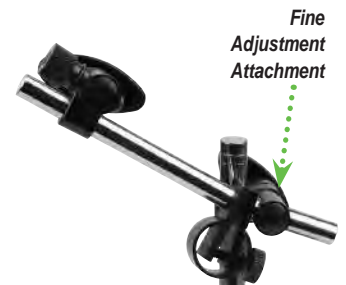

Fine Adjustment Attachment

MBR-1F

Universal Magnetic Base Holders

- Fit any type of dial indicator with lug back
- Magnetic base features an on-off switch with magnetic pull of 110 pounds
- 5/8" diameter 7 1/4" high vertical column
- 3.45" x 1.97" x 2.187" base
- Available with or without Fine Adjustment Feature

Description	Jobber	Order No.
Universal Holder	\$43.99	MBR-1
With Fine Adjustment	45.99	MBR-1F

... another satisfied customer

"We did some testing for our friends at Goodson Tool & Supplies on the M8 head holder for seat and guide machines. This thing is pretty badass!"
 - Jim Robinson, Head Hoggers, Hanceville, AL, Goodson customer since 1992



Left: Easily mount two Milwaukee-Eight™ heads for machining

Below: View of the underside of the plate with heads mounted

Milwaukee-Eight™ Double Head Plate

- Easily mount and machine two Milwaukee-Eight™ cylinder heads at the same time
- The unique design perfectly aligns the centerline of valve guides providing repeatable accuracy from head to head speeding up your machine work
- Heavy enough for cutting and installing guides and seats
- Use with your guide and seat machine, Bridgeport-type mill or CNC
- Measures 12" x 26" x 1 1/4" thick • Blackened Aluminum construction
- Order No. **HHP-M8** Jobber \$879.99



Pan/Shovel Spring Seat Cutting Tool

- Convert Pan & early Shovels to late style Shovel easily to attain higher lift
- Spacer stops the cutter at the correct height for uniform spring spacing
- Use with lower spring collars or stock late-style lower spring collars (1980-1984) • OD: 1.680" • ID: 0.750"



Description	Jobber	Order No.
Spring Seat Cutting Tool	\$102.99	VSS-1680HD
.375" Spring Pad Pilot	37.99	VP-375

Guide Driver for Reduced Diameter Top Valve Guides

The guide top fits into the groove between the driver and the bushing to center and drive the guide into place. Puts pressure on the step top of the guide, not the seal area. Required for installing 20-2120 & 20-2130 series guides (below).
 Order No. **VGD-315420** Jobber \$46.99



Keeper Installation Tools

- Spring-loaded plunger
- For single & multi-groove keepers
- Reaches keeper grooves located farther from the valve tip • Ideal for use with **CF-500** (p. 45) and **PSB-5000** (p. 44)

Best Keeper Tool on the Market!

Size	Jobber	Order No.
5mm / .2031"	\$95.99	VKI-5
6mm / .2344"	95.99	VKI-6
7mm / .2812"	95.99	VKI-7
8mm / .3125"	95.99	VKI-8
Replacement Rubber Sleeve	7.49	VKI-56

.421" Valve Seal Cutter

- Evo/Twin Cam
- Will shorten and re-chamfer the guide top, increasing seal-to-retainer clearance for higher lift camshafts
- Can also be used to modify .530" guides to .421" guides
- Guide OD: .421" • Pilot Size: .312"
- Use with 71010 seal (page 135)
- Order No. **VSC-420312** Jobber \$129.99



V-Twin On-the-Engine Valve Spring Compressor

Replace broken valve springs, install high performance valve springs, remove and replace valve guide seals all without disassembling the bike – just remove the gas tank and get to work. Use on Sportster, Evolution, Twin-Cam and most aftermarket V-Twins. Kit includes valve spring compressor, adaptor for compressing beehive springs, valve seal driver/installer and head pressurizing hose. Order No. **CF-HDIF** Jobber \$179.99



CYLINDER HEAD REBUILDING ASSEMBLY & SAFETY CLEANING SHORT BLOCK REBUILDING FLYWHEEL GRINDING TOOLS & SUPPLIES MISCELLANEOUS TOOLS BRAKE SERVICE TOOLS MEASURING TOOLS V-TWIN & METRIC HARD PARTS

CYLINDER HEAD REBUILDING
CLEANING, ASSEMBLY & SAFETY
SHORT BLOCK REBUILDING
CRANKSHAFT/ FLYWHEEL GRINDING
MISCELLANEOUS TOOLS & SUPPLIES
BRAKE SERVICE TOOLING
MEASURING TOOLS
V-TWIN & METRIC HARD PARTS



.415" Lift Panhead
1948 to 1965
Valve Spring Kit for 3/8" Valve Stems

- OE Replacement
- Fits Intake Valve 20-4257 and Exhaust Valve 20-4195
- Heat-treated and shot peened for long life • Kits include 4 Retainers, 4 Springs, 4 Keepers & 4 Base Washers

Max Lift	Installed Height	Seat Pressure	Open Pressure	@ Lift	MSRP	Jobber	Order No.
.415"	1.375"	129 lbs.	272 lbs.	.415"	\$121.94	\$86.62	20-20430

.600" Lift Shovelhead™
1966 to 1977

Valve Spring Kit For 3/8" Valve Stems

- Lightweight Racing Kits include 4 Retainers, 4 Springs, 4 Keepers and 4 Base Washers • Lightweight, hard anodized 7075T-6 Retainers offset .070" for taller installed height • Base Washers counter-bored for a .665" OD seal
- Use with Intake Valve 20-4194 & Exhaust Valve 20-4195

Max Lift	Installed Height	Seat Pressure	Open Pressure	@ Lift	MSRP	Jobber	Order No.
.600"	1.510"	150 lbs.	385 lbs.	.600"	\$142.97	\$101.56	20-2110

.600" Lift Evolution™
1984 to 1999
Valve Spring Kit For 5/16" Valve Stems

- Heat-treated and shot peened for long life
- Lightweight Racing Kits include 4 Retainers, 4 Springs, 4 Keepers & 4 Base Washers
- Use with Intake Valve 20-4171 & Exhaust Valve 20-4170

Max Lift	Installed Height	Seat Pressure	Open Pressure	@ Lift	MSRP	Jobber	Order No.
.600"	1.810"	163 lbs.	361 lbs.	.600"	\$142.97	\$101.56	20-20132



.600" Lift Shovelhead™
1966 to 1977

Valve Spring Kit For 3/8" Valve Stems

- Springs heat-treated and shot peened for long life
- Lightweight Racing Kits include 4 Steel Retainers, 4 Springs, 4 Keepers and 4 Base Washers
- Use with Intake Valve 20-4194 & Exhaust Valve 20-4195

Max Lift	Installed Height	Seat Pressure	Open Pressure	@ Lift	MSRP	Jobber	Order No.
.600"	1.510"	150 lbs.	385 lbs.	.600"	\$142.97	\$101.56	20-20450



.655" Lift Evolution™
1984 to 1999
Valve Spring Kit For 5/16" Valve Stems

- Springs heat-treated and shot peened for long life
- Lightweight Racing Kits include 4 Retainers, 4 Springs, 4 Keepers (51003-4) and 4 Base Washers
- Use with Intake Valve 20-4171 & Exhaust Valve 20-4170

Max Lift	Installed Height	Seat Pressure	Open Pressure	@ Lift	MSRP	Jobber	Order No.
.655"	1.860"	190 lbs.	465 lbs.	.655"	\$206.04	\$146.36	20-20081



.415" Lift Shovelhead™
1966 to 1977
Valve Spring Kit For 3/8" Valve Stems

- Springs heat-treated and shot peened for long life
- OE Replacement Kit includes 4 Steel Retainers, 4 Springs, 4 Keepers and 4 Base Washers
- Use with Intake Valve 20-4194 & Exhaust Valve 20-4195

Max Lift	Installed Height	Seat Pressure	Open Pressure	@ Lift	MSRP	Jobber	Order No.
.415"	1.375"	129 lbs.	272 lbs.	.415"	\$121.94	\$86.62	20-20435

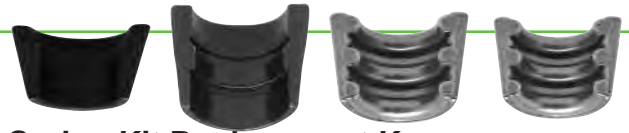

Spring Kit Replacement Keepers

- Several to choose from • 4 Sets per pack

Fits	Stem Dia.	Keeper Angle	Bead Height	OAL	Minor Dia.	MSRP	Jobber	Order No.
Pan/Shovel	.375"	15°	—	.305"	.403"	\$33.30	\$23.69	51005-4
Evolution	.310"	15°	.220"	.365"	.360"	33.30	23.69	51003-4
20-21300	.310"	7°	.190"	.380"	.380"	17.66	12.99	51014-4
20-21500	.310"	9°	.155"	.345"	.398"	33.30	33.99	51031-4
20-21400	.275"	7°	—	.290"	.345"	33.30	23.69	51016-4
20-21550	.275"	9°	.300"	.345"	—	33.30	23.69	51030-4
Milw.-Eight	.236"	7°	—	.200"	—	6.61	47.29	51029-8
Shovelhead 80" Conversion Basewashers (4 Pk.)	—	—	—	—	—	34.80	34.99	20-20855

Compression Release Valves

- 2 per pack
- 10 x 1.0mm thread
- High temperature resistant knobs
- Shorter thread section makes installation easier with less drilling than required with OE-style



Application	Length	Thread	MSRP	Jobber	Order No.
Evolution	1.400"	.350"L	\$68.14	\$44.29	20-21250
Twin Cam	1.730"	.350"L	68.14	44.29	20-21255
OE Replacement	1.750"	.500"L	68.14	44.29	20-21260



.610" Max Lift Beehive Valve Spring Set for 5/16" Valves

- Advanced spring design with special attention to cam and spring harmonics, stress, mass and operating RPM
- Premium grade, super clean ground chrome silicon wire
- Kits include 4 Retainers, 4 Springs, 4 Keepers and 4 Base Washers • Supersedes HVS-6000S

Max Lift	Installed Height	Seat Pressure	Open Pressure	@ Lift	MSRP	Jobber	Order No.
.610"	1.860"	175 lbs.	400 lbs.	.610"	\$184.99	\$131.83	20-21300



.660" Max Lift Beehive Valve Spring Sets for 5/16" Valves

- 9° taper • Advanced spring design with special attention to cam and spring harmonics, stress, mass & operating RPM
- Premium grade, super clean ground chrome silicon wire
- Kits include 4 Retainers, 4 Springs, 4 Keepers and 4 Base Washers • Supersedes HVS-6500S

Max Lift	Installed Height	Seat Pressure	Open Pressure	@ Lift	MSRP	Jobber	Order No.
.660"	1.860"	178 lbs.	371 lbs.	.660"	\$184.99	\$131.83	20-21500



.610" Max Lift Beehive Valve Spring Sets for 7mm Valves

- Advanced spring design
- Premium grade, super clean ground chrome silicon wire
- Kits include 4 Retainers, 4 Springs, 4 Keepers 4 Viton Seals and 4 Base Washers • Supersedes HVS-6000-7SG

Max Lift	Installed Height	Seat Pressure	Open Pressure	@ Lift	MSRP	Jobber	Order No.
.610"	1.860"	175 lbs.	400 lbs.	.610"	\$184.99	\$131.83	20-21400



.660" Max Lift Beehive Valve Spring Sets for 7mm Valves

- 9° taper
- Advanced spring design
- Premium grade, super clean ground chrome silicon wire
- Kits include 4 Retainers, 4 Springs, 4 Keepers, 4 Viton Seals and 4 Base Washers • Supersedes HVS-6500-7SG

Max Lift	Installed Height	Seat Pressure	Open Pressure	@ Lift	MSRP	Jobber	Order No.
.660"	1.860"	178 lbs.	371 lbs.	.660"	\$184.99	\$131.83	20-21550



Evolution™ (04-99), Evo Sportster™ 883cc (96-03) XL™ 1100cc (86-87), Evo Sportster™ 1200cc (88-20), Twin Cam™ 88" (99-04) & Buell™ XB9-XB-12 (03-10)



20-21650



20-23650

Lightweight Racing Dual Spring Kits

- Exact match for installation heights and spring pressures
- Retainers designed for optimum rocker cover clearance
- Includes 4 heavy-duty 9° high-temperature steel keepers, 4 springs, 4 retainers and 4 base washers

Max Lift	Installed Height	Seat Pressure	Open Pressure	@ Lift	MSRP	Jobber	Order No.
Fit 5/16" Valve Stems High Temperature Steel Retainers and BaseWashers Seals Sold Separately							
.650"	1.860"	185 lbs.	440 lbs.	.650"	\$173.97	\$123.59	20-21650
.675"	1.860"	185 lbs.	450 lbs.	.675"	173.97	123.59	20-21600
Fit 7mm Valve Stems High Temperature Steel Retainers and BaseWashers Seals Included							
.650"	1.860"	185 lbs.	440 lbs.	.650"	\$173.97	\$123.59	20-23500
.675"	1.860"	185 lbs.	450 lbs.	.675"	173.97	123.59	20-23600
Fit 7mm Valve Stems Titanium Retainers and High Temperature Steel BaseWashers Seals Included							
.650"	1.860"	185 lbs.	440 lbs.	.650"	\$373.06	\$265.73	20-23550
.675"	1.860"	185 lbs.	450 lbs.	.675"	373.06	265.73	20-23650

CYLINDER HEAD
REBUILDING
CLEANING, ASSEMBLY & SAFETY
SHORT BLOCK
REBUILDING
FLYWHEEL GRINDING
CRANKSHAFT/
TOOLS & SUPPLIES
MISCELLANEOUS
BRAKE SERVICE
TOOLING
MEASURING
TOOLS
V-TWIN & METRIC
HARD PARTS

... another satisfied customer

"Just received my order — two days earlier than expected. Thanks for expediting my order so I can complete the job for my customer."

- Marvin Davenport, Davenport Racing - Goodson Customer since 2014



White Diamond® Hard Chrome Replacement Valves for Milwaukee-Eight™ Heads

- 1-piece forged with White Diamond® hard chrome stems for impervious wear resistance
- Inconel® 751 exhaust valves designed to outperform in the most extreme forced induction or racing applications
- Flow bench tested to optimize intake and exhaust profiles

Type	Head Dia.	Stem Dia.	Radius	Angle	OAL	MSRP	Jobber	Order No.	Material	Supersedes
Intake	1.571" (39.90mm)	0.2347"	0.235"	10°	4.015"	\$29.81	\$28.83	20-21012H	Chrome	20-21012
Intake	1.614" (41.00mm)	0.2347"	0.235"	15°	4.035"	29.81	28.83	20-21060H	Chrome	-----
Intake	1.630" (41.40mm)	0.2347"	0.235"	10°	4.055"	29.81	28.83	20-21009H	Chrome	20-21009
Intake	1.654" (42.01mm)	0.2347"	0.235"	15°	4.032"	29.81	28.83	20-21061H	Chrome	20-21014
Exhaust	1.264" (32.11mm)	0.2342"	0.460"	24°	4.050"	29.81	28.83	20-21016H	Chrome	20-21016
Exhaust	1.284" (32.61mm)	0.2342"	0.460"	24°	4.050"	29.81	28.83	20-21017H	Chrome	20-21017

CYLINDER HEAD REBUILDING
CLEANING, ASSEMBLY & SAFETY
SHORT BLOCK REBUILDING
CRANKSHAFT/ FLYWHEEL GRINDING
MISCELLANEOUS TOOLS & SUPPLIES
BRAKE SERVICE TOOLING
MEASURING TOOLS
V-TWIN & METRIC HARD PARTS

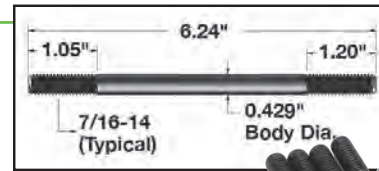
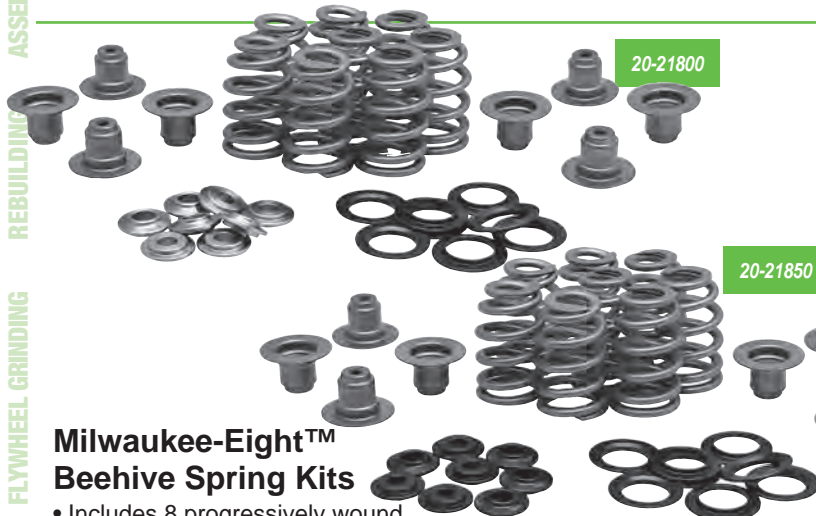

Milwaukee-Eight™ Beehive Spring Kits

- Includes 8 progressively wound ovate wire Beehive Springs, 8 Retainers, 8 Tophat Seals and 8 Spring Bases

Max Lift	Installed Height	Seat Pressure	Open Pressure	@ Lift	MSRP	Jobber	Order No.
Titanium Retainers							
.625"	1.500"	85 lbs.	280 lbs.	.625"	\$416.13	\$295.59	20-21800
Heat Treated Steel Retainers							
.625"	1.500"	85 lbs.	280 lbs.	.625"	312.91	295.59	20-21850

Milwaukee-Eight™ High-Temp Steel Cylinder Studs

- Heat treated 180,000 PSI aircraft alloy steel • Centerless ground to remove material imperfections • Rolled threads
- Black oxide treated for enhanced corrosion resistance • Compatible with factory nuts • Reusable
- Order No. **20-21040**
MSRP \$166.08 **Jobber \$119.62**

Milwaukee-Eight™ Beehive Valve Spring Kits

- Advanced spring design with special attention to cam and spring harmonics, stress, mass and operating RPM
- Premium-grade, super clean ground chrome silicon wire • Heat-treated and shot peened for long life



.465" Max Lift Beehive Valve Spring Kit With Titanium Retainers

- Includes 8 retainers, 8 springs and 8 base washers
- Installed Height: 1.410"
- Seat Pressure: 80 lbs.
- Open Pressure: 212 lbs. at .465"
- Order No. **20-21000**
MSRP: \$313.38 | **Jobber: \$222.60**

.465" Max Lift Beehive Valve Spring Kit With Heat Treated Steel Retainers

- Includes 8 retainers, 8 springs and 8 base washers
- Installed Height: 1.410"
- Seat Pressure: 80 lbs.
- Open Pressure: 212 lbs. at .465"
- Order No. **20-21050**
MSRP: \$250.70 | **Jobber: \$178.09**

.550" Max Lift Beehive Valve Spring Kit With Titanium Retainers

- Supersedes #20-21200
- Includes 8 retainers, springs, base washers and viton tophat seals
- Installed Height: 1.550"
- Seat Pressure: 85 lbs.
- Open Pressure: 257 lbs. at .550"
- Order No. **20-21205**
(supersedes 20-21200)
MSRP: \$416.13 | **Jobber: \$295.60**

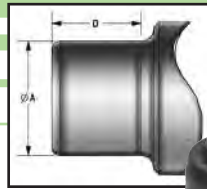

Solid Viton Seals With Metal Jacket & Choker Spring

• 16 Per Package

Stem Dia.	OAL	Seal OD	A	D	MSRP	Jobber	Order No.	Supersedes
7.0mm	0.510"	0.665"	0.560"	0.375"	\$50.25	\$35.70	71028	HVS-7MM
.312"	0.412"	0.566"	0.420"	0.275"	25.73	18.32	71010	HVS-421
.312"	0.514"	0.671"	0.530"	0.330"	50.25	35.70	71045	HVS-531
.375"	0.516"	0.661"	0.562"	0.375"	29.37	20.87	71011	—

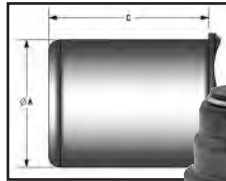

Solid Viton Seals With Metal Jacket & Integral Spring Base

• 16 Per Package

• Spring Shoulder Diameter: 0.970"

Stem Dia.	OAL	Seal OD	A	C	MSRP	Jobber	Order No.	Supersedes
7.0mm	0.974"	1.457"	0.560"	0.700"	\$36.94	\$26.24	71030	HV-7MMOE



Milwaukee-Eight™ Tophat Valve Seal

• 16 Per Package

Stem Dia.	OAL	Seal OD	A	C	MSRP	Jobber	Order No.	Supersedes
6.0mm	0.712"	1.170"	—	—	\$36.94	\$23.68	71046-16	—

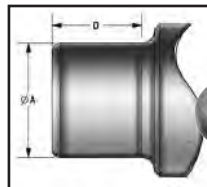

OE Style Seals Solid Teflon With Metal Jacket

16 Per Package

Stem Dia.	OAL	Seal OD	A	D	MSRP	Jobber	Order No.	Supersedes
.312"	0.385"	0.565"	0.420"	0.315"	\$29.37	\$20.87	71032	HSS-420
.312"	0.375"	0.630"	0.530"	0.295"	29.37	20.87	71033	HSS-530312
.343"	0.375"	0.630"	0.530"	0.365"	29.37	20.87	71034	HSS-530343
.375"	0.375"	0.660"	0.562"	0.315"	29.37	20.87	71035	HSS-562
.375"	0.400"	0.720"	0.625"	0.310"	29.37	20.87	71036	HSS-625

Need something not listed here?

We can order just about anything in the Kibblewhite catalog for you.

Call us at 1-800-533-8010 for more information.



Valve Seat Inserts

- For Harley-Davidson®
- Easy to machine
- Effectively dissipate heat for consistent valve sealing
- Hardness increases during engine break-in
- Radiused for easy installation



Replacement Valve Seats For Shovel Head 1200 & 1340

Application	OD	ID	Thick	MSRP	Jobber	Order No.	Supersedes
Exhaust	1.944"	1.575"	.400"	\$10.12	\$7.51	10-HC493	HVS-1944
Intake	2.135"	1.750"	.400"	10.12	7.51	10-HC542	HVS-2135

Oversize Seats For Shovel, Evolution, Twin Cam & M8 – machining required

	OD	ID	Thick	MSRP	Jobber	Order No.	Supersedes
Fits M8	1.630"	1.180"	.385"	\$10.12	\$7.51	10-HC414	HVS-1630
	1.757"	1.410"	.430"	10.12	7.51	10-HC447	HVS-1757
	1.882"	1.520"	.410"	10.12	7.51	10-HC478	HVS-1882
	2.008"	1.610"	.440"	10.12	7.51	10-HC510	HVS-2008
	2.040"	1.700"	.425"	10.12	7.51	10-HC518	HVS-2040
	2.070"	1.610"	.460"	10.12	7.51	10-HC526	HVS-2070
	2.132"	1.800"	.460"	10.12	7.51	10-HC541	HVS-2132
	2.163"	1.750"	.455"	10.12	7.51	10-HC549	HVS-2163

For Iron Head Sportster

Application	OD	ID	Thick	MSRP	Jobber	Order No.	Supersedes
Exhaust	1.757"	1.371"	.430"	\$10.12	\$7.51	10-HC446	HVS-1757S
Intake	2.068"	1.750"	.315"	10.12	7.51	10-HC525	HVS-2068

Universal Repair Seat

	OD	ID	Thick	MSRP	Jobber	Order No.	Supersedes
Powdered	1.339"	1.024"	.375"	\$8.89	\$7.51	10-SC340	MVS-42
Metal	1.693"	1.299"	.434"	10.55	7.51	10-SC430	MVS-58
	1.819"	1.375"	.450"	10.12	7.51	10-HC462	HVS-1820
	1.945"	1.500"	.450"	10.12	7.51	10-HC494	HVS-1945
	2.256"	1.870"	.450"	10.12	7.51	10-HC573	HVS-2257

Nickel Chrome Valve Seats on Page 18

tech tips When installing seats preheat head to 400° and freeze the seat for easier installation. Press fit .006" to .008".



6061-T6 Aluminum Seal Drivers

These installation tools for OE style seals are manufactured from high strength 6061-T6 Aluminum for increased durability when compared to plastic installers.

Application	Color	Fits Seal Up To	Order No.
Evolution	Red	0.575"	20-20830
Pan/Shovelhead 74"	Black	0.673"	20-20833
Ironhead Sportster	White	0.638"	20-20832
Shovelhead 80"	Blue	0.758"	20-20831

MSRP: \$7.27

Jobber \$6.17

... another satisfied customer

"Thank you for a good supply of tooling. Everyone there is very helpful. You don't always find that anymore."
 - John Bursick, Harts Machine Service, Cecil, OH, Goodson Customer since 1997

CYLINDER HEAD REBUILDING
 CLEANING, ASSEMBLY & SAFETY
 SHORT BLOCK REBUILDING
 CRANKSHAFT/ FLYWHEEL GRINDING
 MISCELLANEOUS TOOLS & SUPPLIES
 BRAKE SERVICE TOOLING
 MEASURING TOOLS
 V-TWIN & METRIC HARD PARTS

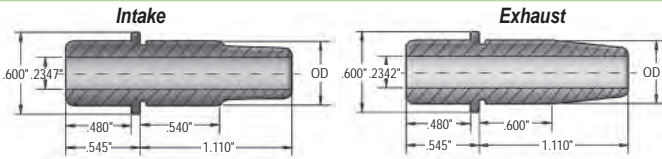

Milwaukee-Eight™ Valve Guides

• Use with 6mm seals (71046 or OE)

Intake				Manganese Bronze	Cast Iron
OD	ID	OAL	Size		
.4750"	.2347"	.1.655"	Std.	20-21020M	20-21020C
.4760"			+ .001"	20-21021M	20-21021C
.4770"			+ .002"	20-21022M	20-21022C
.4850"			+ .010"	20-21029M	20-21029C
Exhaust				Manganese Bronze	Cast Iron
OD	ID	OAL	Size		
.4750"	.2342"	1.655"	Std.	20-21030M	20-21030C
.4760"			+ .001"	20-21031M	20-21031C
.4770"			+ .002"	20-21032M	20-21032C
.4850"			+ .010"	20-21039M	20-21039C
MSRP / Jobber				\$13.12 / \$9.32	\$8.83 / \$6.38

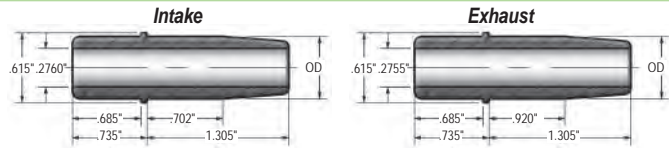

Twin Cam & Evo Sportster w/ 7mm Valves

• Use with 71028 (0.562") Viton Seals

Intake				Manganese Bronze	Cast Iron	Supersedes
OD	ID	OAL	Size			
.5625"	.2760"	2.040"	Std.	20-20690M	—	HVG-6600
.5635"			+ .001"	20-20691M	—	HVG-6601
.5645"			+ .002"	20-20692M	—	HVG-6602
.5725"			+ .010"	20-20699M	—	—
Exhaust				Manganese Bronze	Cast Iron	Supersedes
OD	ID	OAL	Size			
.5620"	.2755"	2.040"	Std.	20-20700M	—	HVG-6700
.5630"			+ .001"	20-20701M	—	HVG-6701
.5640"			+ .002"	20-20702M	—	HVG-6702
.5720"			+ .010"	20-20709M	—	—
MSRP / Jobber				\$13.12 / \$9.32		

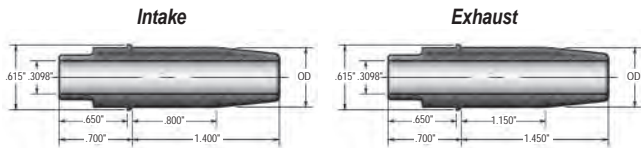

Evolution, Twin-Cam & Evo Sportster With 5/16" Valves (.420" Guide Top)

• Use with 71010 Viton Seals or 71032 OE Style Seals

Intake				Manganese Bronze	Cast Iron	Supersedes
OD	ID	OAL	Size			
.5620"	.3098"	2.100"	Std.	20-2120M	20-2120C	—
.5630"			+ .001"	20-2121M	20-2121C	HVG-5600S
.5640"			+ .002"	20-2122M	20-2122C	HVG-5601S
.5720"			+ .010"	20-2129M	20-2129C	—
Exhaust				Manganese Bronze	Cast Iron	Supersedes
OD	ID	OAL	Size			
.5620"	.3098"	2.150"	Std.	20-2130M	20-2130C	—
.5630"			+ .001"	20-2131M	20-2131C	HVG-5700S
.5640"			+ .002"	20-2132M	20-2132C	HVG-5701S
.5720"			+ .010"	20-2139M	20-2139C	—
MSRP / Jobber				\$13.12 / \$9.32	\$8.83 / \$6.38	

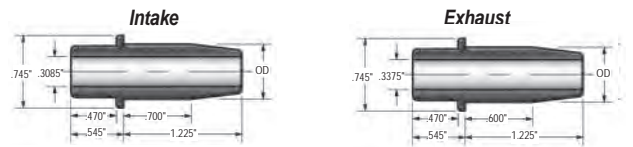

Sportster (1970-1983)

• Use with 71033 (intake) & 71034 (exhaust) OE-Style Seals

Intake				Manganese Bronze	Cast Iron	Supersedes
OD	ID	OAL	Size			
.5650"	.3085"	1.770"	Std.	—	20-2320C	HVG-5100C
.5660"			+ .001"	—	20-2321C	HVG-5101C
.5670"			+ .002"	—	20-2322C	HVG-5102C
.5750"			+ .010"	—	20-2329C	—
Exhaust				Manganese Bronze	Cast Iron	Supersedes
OD	ID	OAL	Size			
.5650"	.3375"	1.770"	Std.	—	20-2330C	HVG-5200C
.5660"			+ .001"	—	20-2331C	HVG-5201C
.5670"			+ .002"	—	20-2332C	HVG-5202C
.5750"			+ .010"	—	20-2339C	—
MSRP / Jobber					\$8.83 / \$6.38	

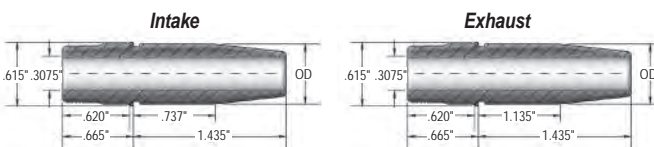

Evolution, Twin-Cam & Evo Sportster With 5/16" Valves (.530" Top Guides)

• Use with 71045 Viton Seals

Intake				Manganese Bronze	Cast Iron	Supersedes
OD	ID	OAL	Size			
.5625"	.3075"	2.100"	Std.	20-20860M	—	HVG-5600
.5635"			+ .001"	20-20861M	—	HVG-5601
.5645"			+ .002"	20-20862M	—	HVG-5602
.5725"			+ .010"	20-20869M	—	—
Exhaust				Manganese Bronze	Cast Iron	Supersedes
OD	ID	OAL	Size			
.5625"	.3096"	2.100"	Std.	20-20870M	—	HVG-5700
.5635"			+ .001"	20-20871M	—	HVG-5701
.5645"			+ .002"	20-20872M	—	HVG-5702
.5725"			+ .010"	20-20879M	—	—
MSRP / Jobber				\$13.12 / \$9.32		

Shovel Head 80" (78-83)

• Use with 71036 OE Style Seals

Intake or Exhaust				Manganese Bronze	Cast Iron	Supersedes
OD	ID	OAL	Size			
.6250"	.3745"	1.910"	Std.	20-2050M	20-2050C	HVG-5400
.6260"			+ .001"	20-2051M	20-2051C	HVG-5401
.6270"			+ .002"	20-2052M	20-2052C	HVG-5402
.6500"			+ .025"	20-50HSM	20-50HSC	—
MSRP / Jobber				\$13.12 / \$9.32	\$8.83 / \$6.38	

Shovel & Pan Heads

• Use with 71011 Viton seals or 71035 OE Style Seals

Intake or Exhaust				Manganese Bronze	Cast Iron
OD	ID	OAL	Size		
.5650"	.3760"	1.900"	Std.	20-2020M	20-2020C
.5660"			+ .001"	20-2021M	20-2021C
.5670"			+ .002"	20-2022M	20-2022C
.5680"			+ .003"	20-2023M	20-2023C
.5750"			+ .010"	20-2029M	20-2029C
MSRP / Jobber				\$13.12 / \$9.32	\$8.83 / \$6.38

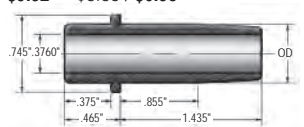
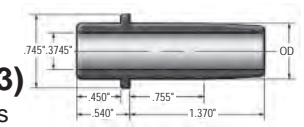



High Performance Valves

Black Diamond™ & White Diamond® Valves for Harley-Davidson® Engines

tech tips Always check and confirm running clearances when installing new valves.
from the techxperts™



- **Light and strong with optimum airflow** A combination of stress analysis and flow bench testing for optimally balanced valve mass, strength and airflow characteristics.
- **Black Diamond™ Valves** One piece forged stainless steel valves impregnated by a special German process to improve wear properties and reduce friction. Provides resistance to corrosion and superior wear.
- **Chrome Diamond® Valves** One piece forged with White Diamond® hard chrome stems. Inconel® 751 exhaust valves are designed to perform even in the most extreme conditions. Flow bench tested to optimize intake and exhaust profiles.

Application	Type	Head Diameter	Stem Diameter	Tulip Radius	Tulip Angle	Overall Length	MSRP	Jobber	Order No.	Supersedes
Milwaukee-Eight	Intake	1.571" (39.90mm)	0.2347"	0.235"	10°	4.015"	\$29.81	28.83	20-21012H	20-21012
	Intake	1.614" (41.00mm)	0.2347"	0.235"	15°	4.035"	29.81	28.83	20-21060H	-----
	Intake	1.630" (41.40mm)	0.2347"	0.235"	10°	4.055"	29.81	28.83	20-21009H	20-21009
	Intake	1.654" (42.01mm)	0.2347"	0.235"	15°	4.032"	29.81	28.83	20-21061H	20-21014
	Exhaust	1.264" (32.11mm)	0.2342"	0.460"	24°	4.050"	29.81	28.83	20-21016H	20-21016
	Exhaust	1.284" (32.61mm)	0.2342"	0.460"	24°	4.050"	29.81	28.83	20-21017H	20-21017
Pan Head 1948-1965 Black Diamond™	Intake	1.750" (44.45mm)	0.3765"	0.234	23°	3.800"	29.81	21.18	20-4257	-----
	Exhaust	1.750" (44.45mm)	0.3760"	0.234	29°	3.820"	25.10	17.83	20-4195	-----
Sportster 1957-1969	Intake	1.825" (46.36mm)	0.3090"	0.375	23°	3.562"	37.55	26.68	20-4258	-----
	Exhaust	1.570" (39.88mm)	0.3384"	0.236	29°	3.512"	29.81	17.83	20-4197	HEV-3
	Exhaust	1.630" (41.40mm)	0.3384"	0.236	29°	3.512"	37.55	26.68	20-4197-1	-----
Sportster 1970-1983	Intake	1.935" (49.15mm)	0.3090"	0.256	23°	3.620"	25.10	17.83	20-4196	HEV-5
	Intake	1.950" (49.53mm)	0.3090"	0.256	23°	3.690"	37.55	26.68	20-4167	-----
	Intake	2.000" (50.80mm)	0.3090"	0.256	23°	3.620"	29.81	21.18	20-4196-1	-----
	Exhaust	1.570" (39.88mm)	0.3384"	0.236	29°	3.512"	25.10	17.83	20-4197	HEV-3
Shovelhead 74" & 80" 1966-1983	Intake	1.950" (49.53mm)	0.3765"	0.234	23°	3.885"	25.10	17.83	20-4194	HEV-9
	Intake	2.000" (50.80mm)	0.3765"	0.234	23°	3.885"	29.81	21.18	20-4256	-----
	Exhaust	1.750" (44.45mm)	0.3760"	0.234	29°	3.810"	25.10	17.83	20-4195	HEV-7
Shovelhead 74" & 80" 66-83 "Fat Stem"	Exhaust	1.812" (46.02mm)	0.3760"	0.234	29°	3.820"	37.55	26.68	20-4195-1	-----
	Intake	1.950" (49.53mm)	0.3780"	0.234	23°	3.885"	29.81	21.18	20-4294	-----
	Exhaust	1.750" (44.45mm)	0.3775"	0.234	29°	3.810"	29.81	21.18	20-4295	-----
Evolution 1984-1999	Intake	1.840" (46.74mm)	0.3100"	0.236	23°	4.445"	25.10	17.83	20-4171	-----
	Intake	1.990" (50.55mm)	0.3108"	0.675	25°	4.440"	34.63	24.60	20-20905	HBV-1990
	Intake	1.940" (49.28mm)	0.3108"	0.675	25°	4.440"	34.63	24.60	20-20910	HBV-1940
	Intake	1.900" (48.26mm)	0.3108"	0.675	25°	4.440"	34.63	24.60	20-20915	HBV-1900
	Intake (Racing)	1.900" (48.26mm)	0.3100"	0.344	28°	4.420"	25.10	17.83	20-4171R	HBV-1900S
	Intake	2.150" (54.61mm)	0.3108"	0.550	24°	4.480"	34.63	24.60	20-20900	HCV-2150
	Exhaust	1.615" (41.02mm)	0.3096"	0.236	29°	4.525"	25.10	17.83	20-4170	HEV-10
	Exhaust (Racing)	1.630" (41.40mm)	0.3096"	0.500	40°	4.525"	25.10	17.83	20-4170R	-----
	Exhaust	1.650" (41.91mm)	0.3106"	0.750	25°	4.515"	34.63	24.60	20-20920	HBV-1650
	Exhaust	1.610" (40.89mm)	0.3106"	0.750	25°	4.510"	34.63	24.60	20-20925	HBV-1610D
	Exhaust	1.585" (40.26mm)	0.3106"	0.750	25°	4.505"	34.63	24.60	20-20930	HBV-1585
Evo Sportster 883 to 1200 88 - 03	Intake	1.715" (43.56mm)	0.3100"	0.236	23°	4.550"	37.55	26.68	20-2010	HBV-1720
Twin Cam 88"-103" 2005-2017	Exhaust	1.480" (37.59mm)	0.3096"	0.500	40°	4.625"	37.55	37.07	20-2012	-----
	Intake	1.805" (45.85mm)	0.2760"	0.413	1.700°R	4.420"	29.81	21.18	20-20322	HBV-1810-7TG
	Intake	1.900" (48.26mm)	0.2760"	0.344	28°	4.420"	29.81	21.18	20-20323R	-----
	Exhaust	1.575" (40.00mm)	0.2755"	0.354	22°	4.520"	29.81	21.18	20-20325	-----
Buell® XB9™ 2003-2007	Exhaust	1.630" (41.40mm)	0.2755"	0.500	34°	4.520"	29.81	21.18	20-20326R	-----
	Intake	1.805" (45.85mm)	0.2760"	0.344	28°	4.525"	54.10	38.43	20-20260	-----
	Intake	1.900" (48.26mm)	0.2760"	0.344	28°	4.500"	54.10	38.43	20-20262	-----
Twin Cam, Sportster & Buell® Triple Groove	Intake	1.980" (50.29mm)	0.2757"	0.290	23°	4.455"	34.63	24.71	20-20935	HBV-1980-7TG
	Intake	1.900" (48.26mm)	0.2757"	0.475	24°	4.445"	34.63	24.71	20-20940	HBV-1900-7TG
	Exhaust	1.610" (40.89mm)	0.2755"	0.595	25°	4.545"	34.63	24.71	20-20945	HBV-1610-7TG
Evo, Big Twin & Twin Cam	Exhaust	1.575" (40.05mm)	0.2755"	0.595	25°	4.560"	34.63	24.71	20-20950	HBV-1575-7TG
	Intake	2.020" (51.31mm)	0.3108"	0.670	25°	4.440"	34.63	24.71	20-20990	HBV-2020A
S&S®, Screaming Eagle & Ultima®	Exhaust	1.700" (43.18mm)	0.3106"	0.600	25°	4.535"	34.63	24.71	20-20960	HBV-1700A
SE® / JIMS®	Intake	2.020" (51.31mm)	0.3108"	0.645	25°	4.510"	34.63	24.71	20-20965	HBV-2020S
	Exhaust	1.610" (40.89mm)	0.3106"	0.750	25°	4.565"	34.63	24.71	20-20970	HBV-1610S
Blank Valves Ready to Machine To Your Specs	Exhaust	2.100" (53.34mm)	0.3108"	0.560	24°	4.475"	34.63	24.71	20-20955	HBV-2100
	Black	2.100" (53.34mm)	0.3108"	-----	24°	5.700"	37.53	26.77	20-20980	HBV-1700BC
	Chrome	1.700" (43.18mm)	0.3106"	-----	25°	5.700"	37.53	26.77	20-20985	HCV-2100BC
	Chrome	2.200" (55.88mm)	0.3108"	-----	25°	5.700"	37.53	26.77	20-20975	HCV-2200BC

CYLINDER HEAD
REBUILDING
ASSEMBLY & SAFETY
SHORT BLOCK
REBUILDING
FLYWHEEL GRINDING
CRANKSHAFT/
TOOLS & SUPPLIES
MISCELLANEOUS
BRAKE SERVICE
MEASURING
TOOLS
V-TWIN & METRIC
HARD PARTS

RAPIDEX

A rapid-use index of product categories

Cylinder Head Rebuilding

Pilots.....	5-7
Valve Seat Work.....	8-26
Valve Refacing.....	27-31
Reamers.....	32-33
Valve Guide Resizing.....	34-36
Valve Guide Replacement.....	37-41
Valve Seal Work.....	42
Valve Spring Work.....	43-48
Cylinder Head Resurfacing.....	49-53
Crack Detection & Repair.....	54-57
Porting & Polishing.....	60-62

Cleaning, Assembly & Safety

Parts Storage & Organizers.....	63-65
Parts Baskets.....	65
Wire Wheels & Brushes.....	66-67
Cleaning.....	68-71
Last Blast Paint & Metal Markers.....	72
Assembly Lubes.....	73
Coolants & Lubricants.....	74-76

Index	77-84
Flex-Hones®.....	85

Short Block Rebuilding

Boring Bar Tooling & Supplies.....	86-87
Cylinder Honing.....	88-94
Rod Honing.....	93
Rod & Piston Work.....	95-98
Lifter Bore Tooling.....	101
Camshaft Work.....	102-103

Crankshaft/Flywheel Grinding

Crankshaft Grinding Wheels.....	104-105
Crankshaft Grinding & Polishing.....	106-111
Flywheel Grinding.....	112-115

Miscellaneous Tools

Diamond Dresser Tools.....	116-117
Miscellaneous.....	118

Brake Service Tooling

Brake Tips & Holders.....	119-120
Brake Lathe Silencers.....	121
Brake Lathe Replacement Parts.....	122-124

Measuring Tools

Straight Edges.....	125
Dial Bore Gauges.....	127-128
Calipers & Dial Indicators.....	129
Micrometers.....	130

V-Twin Hard Parts

Valve Springs.....	132-135
Seats & Seat Inserts.....	135
Valve Guides.....	136
Replacement Valves.....	137

© Copyright 2022, Goodson Mfg. Co., Inc. All copy and illustrations are copyrighted. Absolutely no mechanical or electronic reproduction or use of any part is allowed without our prior written permission. Goodson reserves the right to correct printing errors. Prices are subject to change without notice.

Magnetic Finger Glove

- Turns your index finger into a powerful tool
- Holds any small magnetic part securely
- Complete jobs faster with less effort
- No more cuts from installing and retrieving metal parts • One size fits most
- Order No. **RW-MAG** Jobber \$9.99



GOODSON Gear

Sport Goodson gear around the shop, at the track or just out and around!

RW-GR-CAP

Description	Color	Sizes	Jobber	Order No.
Ladies' Cut Cotton T-Shirt	Black	Medium	\$14.99	RWW-GTB-M
		Large	14.99	RWW-GTB-L
		X-Large	14.99	RWW-GTB-XL
Pre-Shrunk Cotton T-Shirts	White	Medium	12.99	RW-GTW-M
		Large	12.99	RW-GTW-L
		X-Large	12.99	RW-GTW-XL
	Black	XX-Large	12.99	RW-GTW-XXL
		Medium	12.99	RW-GTB-M
		Large	12.99	RW-GTB-L
		X-Large	12.99	RW-GTB-XL
		XX-Large	12.99	RW-GTB-XXL
Caps	Black	adjustable	7.99	RW-GR-CAP
Shop Apron	Black	n/a	36.99	CA-100
Can Cooler	Black	n/a	1.49	RW-CC
Magnetic Finger Glove		n/a	9.99	RW-MAG

CYLINDER HEAD REBUILDING
CLEANING, ASSEMBLY & SAFETY
SHORT BLOCK REBUILDING
CRANKSHAFT/FLYWHEEL GRINDING
MISCELLANEOUS TOOLS & SUPPLIES
BRAKE SERVICE TOOLING
MEASURING TOOLS
V-TWIN & METRIC HARD PARTS

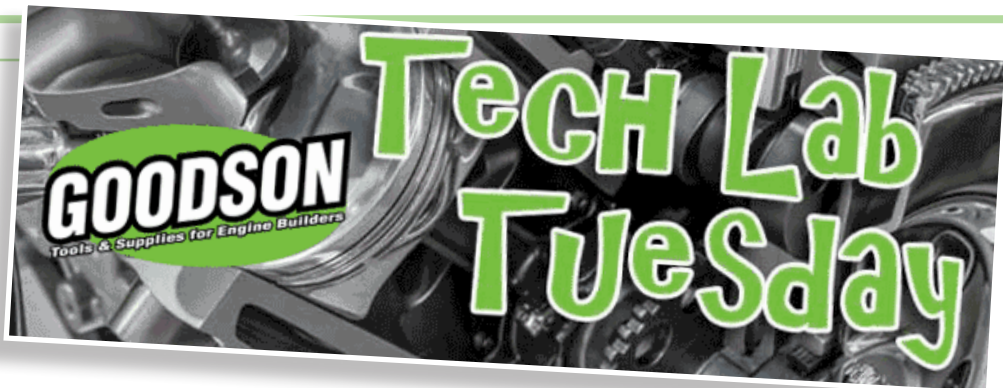

Goodson Is Producing A Video Series — Tech Lab Tuesday

Every Tuesday we premier a new episode in which we explain how to use Goodson products to make your job easier. This is NOT purely a sales pitch. Dave gets right into our on-site tech lab to demonstrate how these tools work. Some of the topics we've covered so far include:

- Adjustable Counterbore Cutter Kit
- Milwaukee-Eight™ Head Plate
- Using the Goodson Pistol Grip Vacuum Tester
- Using Core Drill/Reamers To Remove Valve Guides
- Choosing the Right Valve Refacer Wheel
- Expanding Your Valve Refacer's Capacity
- Removing Dowel Pins
- Choosing the Right Flywheel Grinding Stone

How To Watch Tech Lab Tuesday

It's easy. There are several options:

1. **Get a notification by email** when the new episode is available. If you haven't already signed up to get emails from Goodson, head on over to the website (goodson.com) to sign up. You can also email webtechs@goodson.com to let us know you want to receive email from us and we'll get you added to the list.
2. **Follow Goodson on Social Media.** We announce the premier of the videos on Facebook, Instagram and Twitter where you'll get a link to the video.
3. **Subscribe to our YouTube Channel.** You'll find us at <https://www.youtube.com/c/GoodsonShopSupplies>. By subscribing, you'll receive alerts that new videos have been added.
4. **Visit goodson.com.** All videos are posted on our Blog and tagged with Tech Lab Tuesday so you'll be able to find them easily.



Scan the code with your smart phone or other smart device to visit the Tech Lab Tuesday section of the Goodson website



GOODSON

Tools and Supplies for Engine Builders

156 Galewski Drive | Winona, MN 55987

Easy Toll-Free Ordering by Phone
1-800-533-8010

Toll-Free Fax 24-Hours a Day
1-888-466-3909

Order Online!
www.goodson.com

Source Code

Account Number

Stay Connected
With Goodson



GoodsonToolsAndSupplies



goodsontools



@GoodsonTools



@GoodsonDave



Goodson ShopSupplies



Goodson Gazette

employee
owned

Goodson EXCLUSIVE

Products you'll only
find from Goodson



BLG-1000 (p. 47)



031-3100-20 (p. 21)



MGA-MIC (p. 4)

RRJ-350 (p. 107)



SABER TOOTH
SERIES CUTTER
BLADES
(pg. 9-13)